

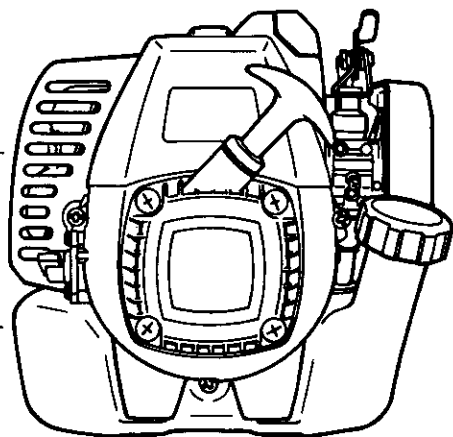

MODEL

ECO22GR/GA/GRV/GR(F)
ECO25GR/GA/GRV/GR(F)

INSTRUCTIONS FOR USE
MANUEL D'UTILISATION
BEDIENUNGSANLEITUNG
GEBRUIKSAANWIJZING



CE1

ISSUE EMD-EU1091









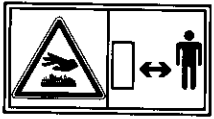
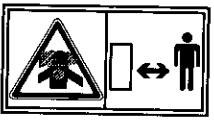

1ZZ9990007

Robin Engines

CONTENTS

1. SAFETY PRECAUTIONS	1
2. COMPONENTS	4
3. PRE-OPERATION CHECKS	6
4. OPERATING YOUR ENGINE.....	7
5. EASY TROUBLESHOOTING.....	13
6. MAINTENANCE SCHEDULE	15
7. "HOW-TO" MAINTENANCE	16
8. PREPARATIONS FOR STORAGE	19
9. SPECIFICATIONS	20

SYMBOLS

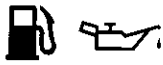
		<p><i>Read the owner's manual.</i></p>	
		<p><i>Stay clear of the hot surface.</i></p>	
		<p><i>Exhaust gas is poisonous. Do not operate in an unventilated area.</i></p>	
		<p><i>Stop the engine before refueling.</i></p>	
		<p><i>Fire, open flame and smoking prohibited.</i></p>	
	<p><i>On (Run)</i></p>		<p><i>Plus; Positive polarity</i></p>
	<p><i>Off (Stop)</i></p>		<p><i>Battery</i></p>
	<p><i>Engine oil</i></p>		<p><i>Engine start (Electric start)</i></p>
	<p><i>Add oil</i></p>		
	<p><i>Mixing ratio of gasoline and oil for 2 cycle fuel.</i></p>		
<p>25:1</p>			

1. SAFETY PRECAUTIONS

Please make sure you review each precaution carefully.

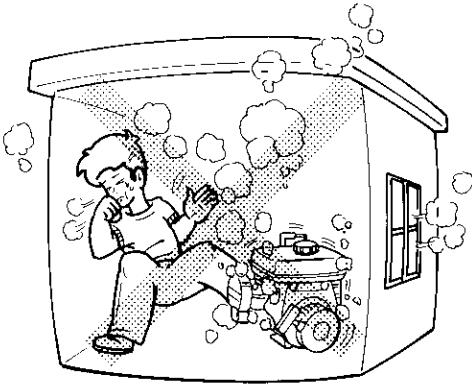

EXHAUST PRECAUTIONS

- Never inhale exhaust gasses. They contain carbon monoxide, a colorless, odorless and extremely dangerous gas which can cause unconsciousness or death.
- Never operate the engine indoors or in a poorly ventilated area, such as tunnel, cave, etc.
- Exercise extreme care when operating the engine near people or animals.
- Keep the exhaust pipe free of foreign objects.

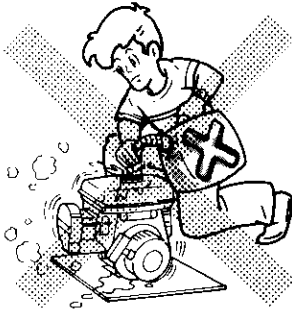

REFUELING PRECAUTIONS

- Be sure to stop the engine prior to refueling.
- Do not overfill the fuel tank.
- If fuel is spilt, wipe it away carefully and wait until the fuel has dried before starting the engine.
- After refueling, make sure that the fuel cap is secure to prevent spillage.



FIRE PREVENTION

- Do not operate while smoking or near an open flame.
- Do not use around dry brush, twigs, cloth rags, or other flammable materials.
- Keep the engine at least 3 feet (1 meter) away from buildings or other structures.
- Keep the engine away from flammables and other hazardous materials (trash, rags, lubricants, explosives).

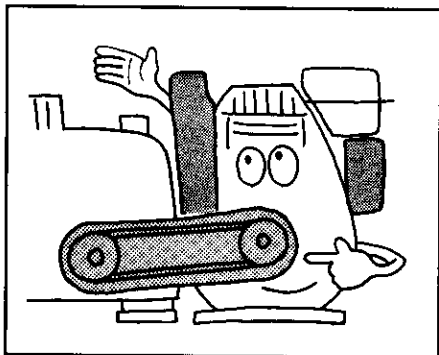

PROTECTIVE COVER

- **Place the protective covers over the rotating parts.**

If rotating parts such as the drive shaft, pulley, belt, etc. are left exposed, they are potentially hazardous.

To prevent injury, equip them with protective covers or shrouds.

- **Be careful of hot parts.**

The muffler and other engine parts become very hot while the engine is running or just after it has stopped.

Operate the engine in a safe area and keep children away from the running engine.

- **Never make adjustments on the machinery while it is connected to the engine, without first removing the ignition cable from the spark plug.**

Turning over the machinery by hand during adjusting or cleaning might start the engine, and machinery with it, causing serious injury to the operator.

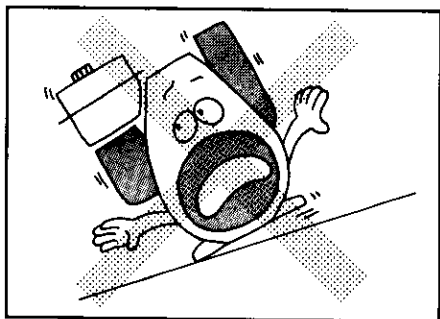

SURROUNDINGS

- **Operate the engine on a stable, level surface free of small rocks, loose gravel, etc. Type GR(F)**
(Circulation carburetor model)

- **Operate the engine on a level surface.**

If the engine is tilted, fuel spillage may result. Type GR(F)
(Circulation carburetor model)

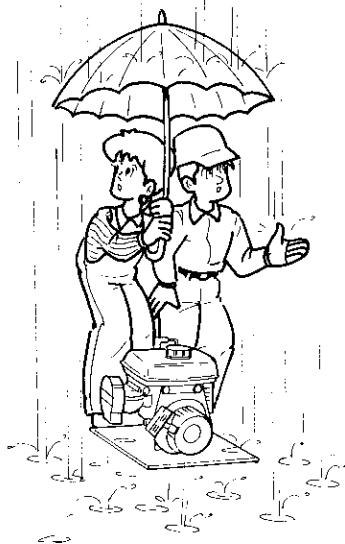

- **Be careful of fuel spillage when transporting the engine.**

Tighten the fuel tank cap securely and close the fuel strainer cock before transport.

- **Do not move the engine while in operation when it has been removed from the equipment.**

- **Keep the unit dry. (do not operate it in rainy conditions).**

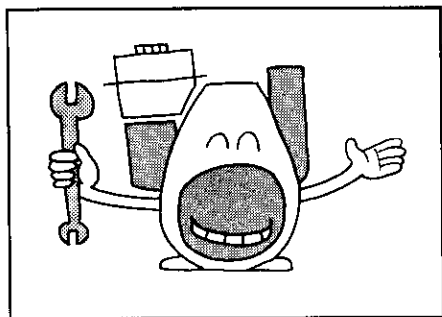

PRE-OPERATION CHECKS

- **Carefully check fuel pipes and joints for looseness and fuel leakage.**
Leaked fuel creates a potentially dangerous situation.

- **Check bolts and nuts for looseness.**
A loose bolt or nut may cause serious engine trouble.

- **Check the fuel level and refill if necessary.**
Take care not to overfill the tank.

- **Wear snug fitting working clothes when operating the engine.**
Loose aprons, towels, belt, etc., may be caught in the engine or drive train, causing a dangerous situation.

2. COMPONENTS

[DIAPHRAGM TYPE CARBURETOR / EC022GR, GA, GRV]
/ EC025GR, GA, GRV]

ILLUSTRATION SHOWS TYPE "GRV".

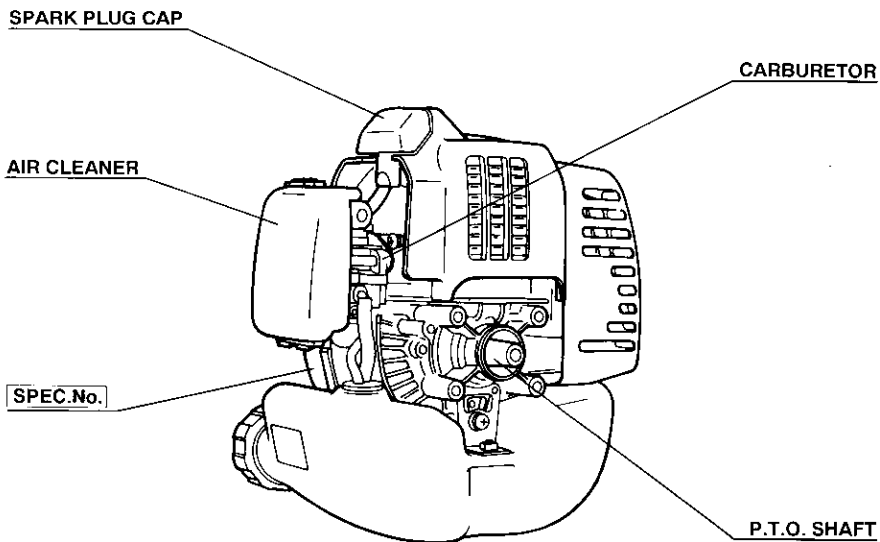
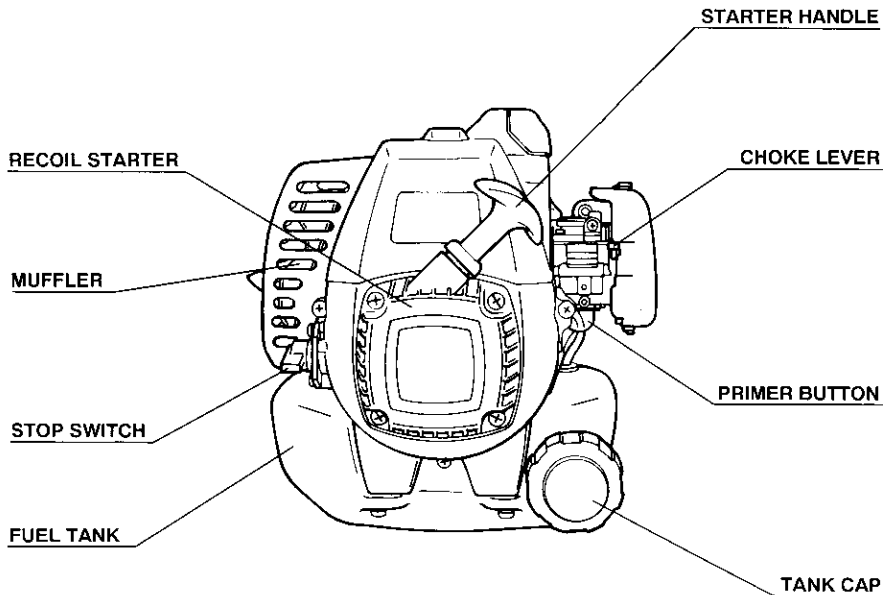

[CIRCULATION TYPE CARBURETOR / EC022GR (F), EC025GR (F)]

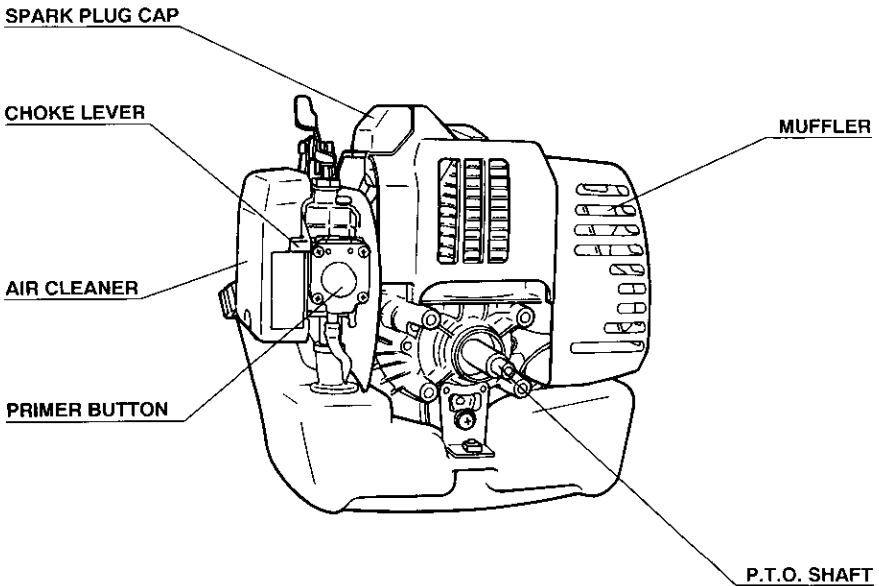
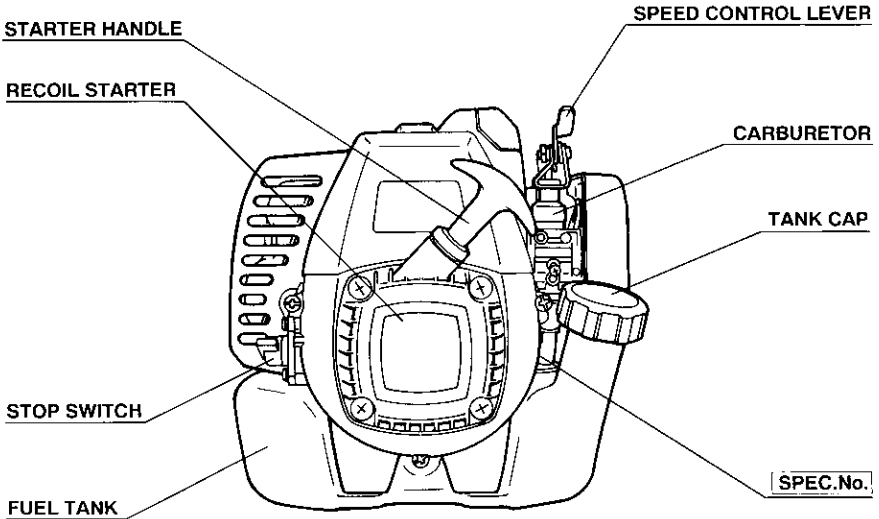

3. PRE-OPERATION CHECKS

CHECK FUEL

- The fuel tank capacity is approx. 0.6 liter.
- Use the mixture fuel prepared by mixing gasoline and exclusive 2-cycle oil at a ratio of 25 : 1, or the 2-cycle fuel now available on the market.
- For break-in of a new engine, use mixture fuel of gasoline 20 : 1 2-cycle engine oil, during first ten hours of operation.
- Wipe off spilt fuel before starting engine.

WARNING

- Do not smoke while refueling.
- Be sure to stop the engine while refueling.
- Never operate the engine with gasoline only.

TO INSTALL REMOTE CONTROL WIRE (DIAPHRAGM TYPE)

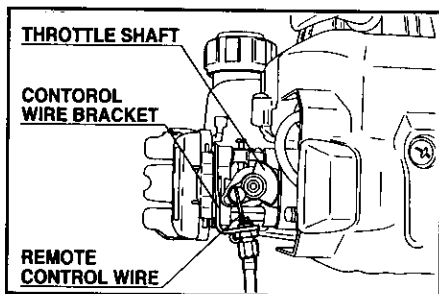

This engine is designed to accept a remote control wire.

1. Use control wire which will fit into 2.5 mm (0.098 in.) dia. wire hole and 6 mm (0.236 in.) dia. casing.
2. Attach the control wire and casing to the engine through the control wire bracket.

4. OPERATING YOUR ENGINE

[DIAPHRAGM TYPE CARBURETOR]

STARTING

STOP SWITCH

1

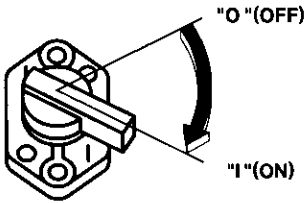

Turn the STOP SWITCH clockwise to the position "1".

REMOTE CONTROL WIRE

3

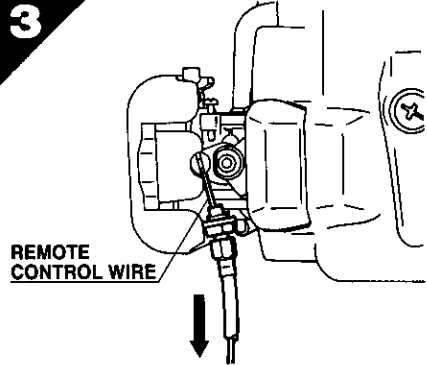

Set the remote control wire at the position 1/3 of the way toward the high speed position.

PRIMER BUTTON

2

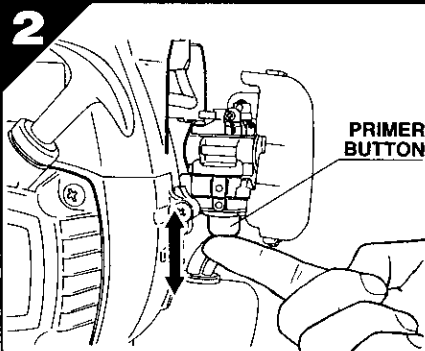

Push the primer button to feed the fuel to the carburetor until fuel overflows from the carburetor.

CHOKE LEVER

4

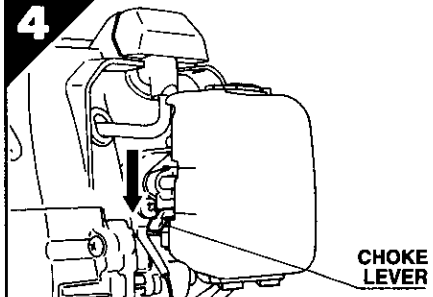

Close the choke lever.

- If the engine is warm or the ambient temperature is high, close the choke lever half-way, or keep it fully open.
- If the engine is cold, or the ambient temperature is low, close the choke lever.

RUNNING

RECOIL STARTER

5

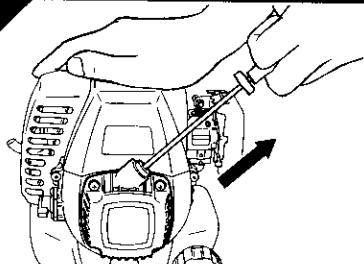

- Pull the starter handle slowly until resistance is felt. This is the "compression" point. Return the handle to its original position and pull swiftly.
- Do not pull out the rope all the way.
- After starting the engine, allow the starter handle to return to its original position while still holding the handle.

CHOKE LEVER

6

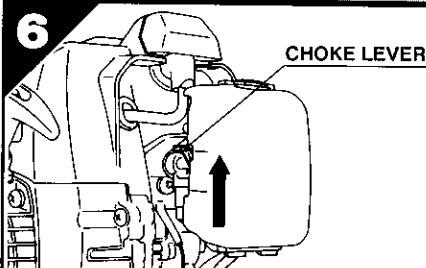

- After starting the engine, gradually open choke by turning the choke lever and finally keep it fully opened.
- Do not fully open the choke lever immediately when the engine is cold or the ambient temperature is low, because the engine may stop.

REMOTE CONTROL WIRE

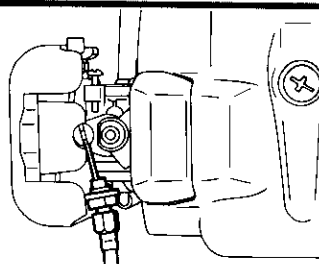

LOW

After the engine starts, set the remote control wire at the low speed position and warm it up without a load for a few minutes.

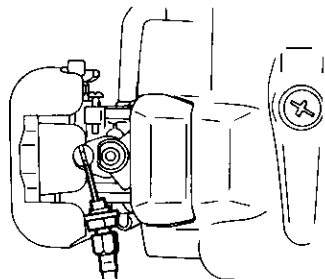

HIGH

Gradually move the remote control wire toward the high speed position and set it at the required engine speed.

NOTE:

Whenever high speed operation is not required, slow the engine down (idle), by moving the speed control lever to save fuel and extend engine life.

STOPPING

REMOTE CONTROL WIRE

1

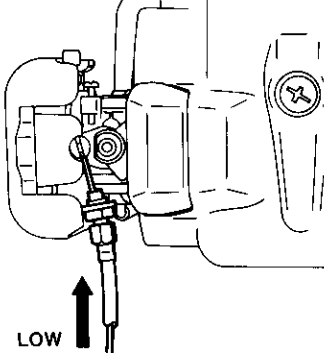

Set the remote control wire at the low speed position and allow the engine to run at low speed for 2 or 3 minutes before stopping.

STOP SWITCH

2

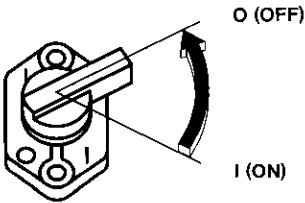

Turn the STOP SWITCH counter-clockwise to the position "O".

RECOIL STARTER

3

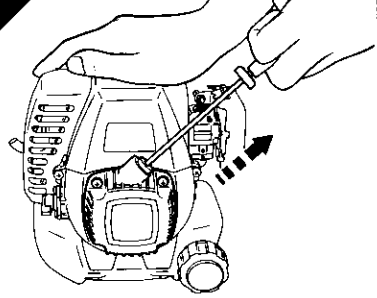

- Pull the starter handle slowly and return the handle to its original position when resistance is felt.

NOTE:

The above operation is necessary to prevent outside moist air from intruding into the combustion chamber.

[CIRCULATION TYPE CARBURETOR]

STARTING

STOP SWITCH

1

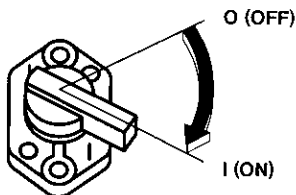

Turn the STOP SWITCH clockwise to the position "I".

SPEED CONTROL LEVER

3

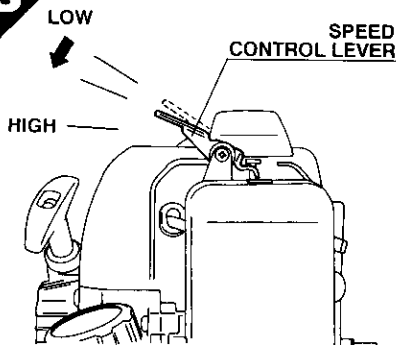

Set the speed control lever 1/3 of the way towards the high speed position.

PRIMER BUTTON

2

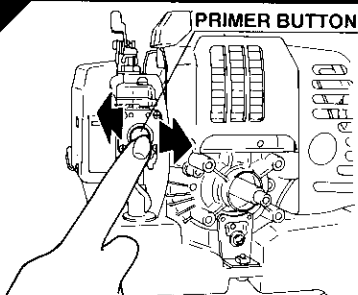

Push the primer button five to seven times to feed the fuel to the carburetor.

NOTE:

This procedure is necessary every time for starting even after the restarting soon after engine stopping.

CHOKE LEVER

4

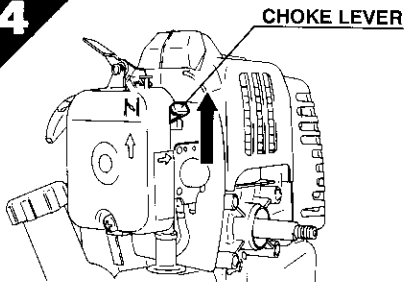

Close the choke lever.

- If the engine is warm or the ambient temperature is high, close the choke lever half-way, or keep it fully open.
- If the engine is cold, or the ambient temperature is low, close the choke lever.

RUNNING

RECOIL STARTER

5

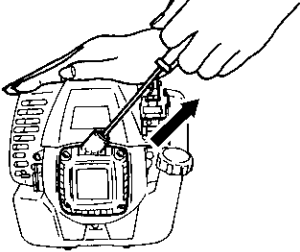

- Pull the starter handle slowly until resistance is felt. This is the "compression" point. Return the handle to its original position and pull swiftly.
- Do not pull out the rope all the way.
- After starting the engine, allow the starter handle to return to its original position while still holding the handle.

CHOKE LEVER

6

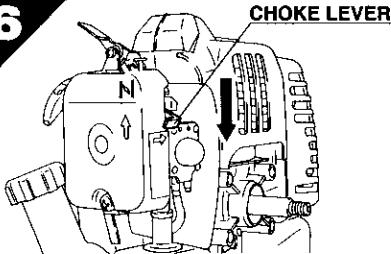

- After starting the engine, gradually open choke by turning the choke lever and finally keep it fully opened.
- Do not fully open the choke lever immediately when the engine is cold or the ambient temperature is low, because the engine may stop.

SPEED CONTROL LEVER

LOW

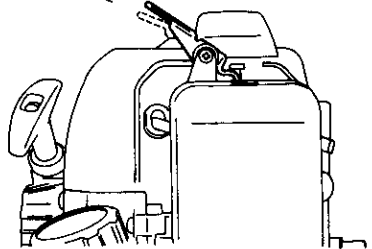

After the engine starts, set the speed control lever at the low speed position and warm it up without a load for a few minutes.

HIGH

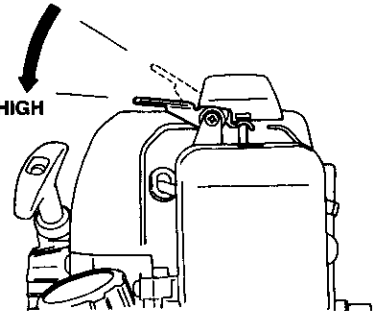

Gradually move the speed control lever toward the high speed position and set it at the required engine speed.

NOTE:

Whenever high speed operation is not required, slow the engine down (idle), by moving the speed control lever to save fuel and extend engine life.

STOPPING

SPEED CONTROL LEVER

1

LOW

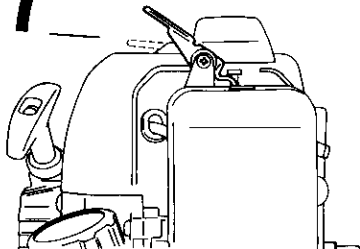

Set the speed control lever at the low speed position and allow the engine to run at low speed for 2 or 3 minutes before stopping.

STOP SWITCH

2

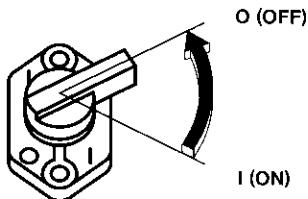

Turn the STOP SWITCH counter-clockwise to the position "O".

RECOIL STARTER

3

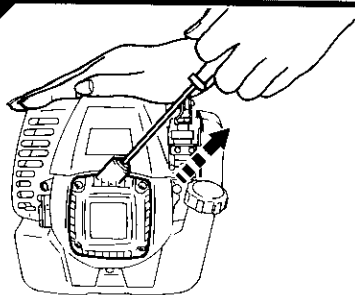

- Pull the starter handle slowly and return the handle to its original position when resistance is felt.

NOTE:

The above operation is necessary to prevent outside moist air from intruding into the combustion chamber.

5. EASY TROUBLESHOOTING

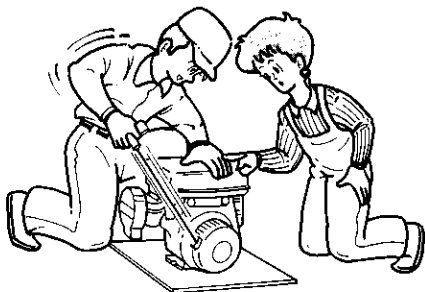

WHEN ENGINE DOES NOT START:

- Perform the following checks before you take the engine to your Robin dealer.
- If you still have trouble after completing the checks, take the engine to your nearest Robin dealer.

Is the engine switch tuned ON?

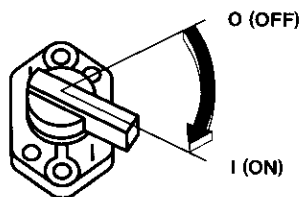

Is there enough compression?

1. Pull the starter handle slowly and check if resistance is felt.
2. If little force is required to pull the starter handle, check if the spark plug is tightened firmly.
3. If the spark plug is loose, tighten it.

Is the spark plug wet with gasoline?

1. Choke (close choke lever) and pull the starter handle five or six times. Remove the plug and check if its electrode is wet. If the electrode is wet, fuel is well supplied to your engine.
2. When the electrode is dry, check where the fuel stops. (Check the fuel intake of the carburetor and fuel strainer intake).
3. In case the engine does not start with well supplied fuel, try using fresh fuel.

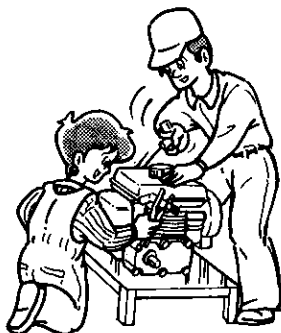

Is there a strong spark across the electrode ?

1. Remove the spark plug and connect it to the plug cap.
Pull the starter handle while grounding spark plug against engine body using an insulated pliers.
2. Try with a new spark plug if the spark is weak or there is no spark.
3. The ignition system is faulty if there is no spark with a new spark plug.
Take your engine to your nearest Robin dealer.

WARNING

- **Before testing, carefully wipe up spilled gasoline. Use an insulated pliers to hold the spark plug in order to prevent from getting electric shocks. Hold the plug as far as possible from the spark plug hole. Ground the side of the electrode to any engine ground.**

6. MAINTENANCE SCHEDULE

DAILY INSPECTION

Before running the engine, check the following service items.

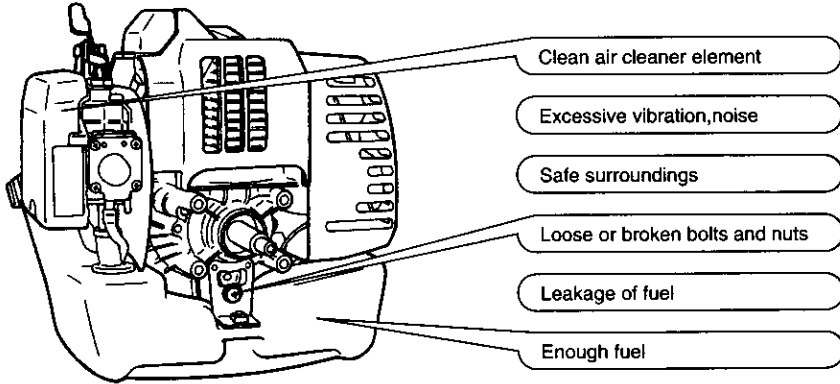

PERIODIC INSPECTION

Periodic maintenance is vital to the safe and efficient operation of your engine.

Check the table below for periodic maintenance intervals.

The following chart is based on the normal engine operation schedule.

	8 hours (Daily)	50 hours (Weekly)	200 hours (Monthly)	500 hours	1000 hours
CLEAN ENGINE AND CHECK BOLTS AND NUTS	● (Daily)				
CLEAN SPARK PLUG		●			
CLEAN AIR CLEANER		●			
CLEAN FUEL FILTER			●		
CLEAN AND ADJUST SPARK PLUG GAP			●		
CLEAN AND ADJUST CARBURETOR				●	
CLEAN MUFFLER AND EXHAUST PORT				●	
OVERHAUL ENGINE IF NECESSARY				●	●

CAUTION : Replace rubber pipes for fuel passage every two years.
Whenever fuel leakage is found, replace the leaky pipe immediately.

7. "HOW-TO" MAINTENANCE

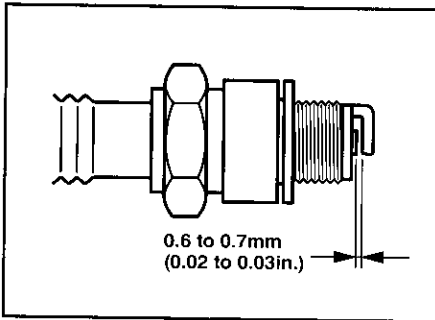

INSPECTING THE SPARK PLUG

- Clean off carbon deposits on the spark plug electrode using a plug cleaner or wire brush.
- Check electrode gap.
Adjust it to between 0.6 mm and 0.7 mm (0.02 and 0.03 inches).
- Use a proper spark plug ;

NGK : BM7A
CHAMPION : CJ4, CJ6

MAGNETO

Gap between coil core and flywheel	0.3 - 0.4 mm
------------------------------------	--------------

ADJUSTING CARBURETOR

Adjusting idling rpm

When adjust screw is turned right, engine rpm increases, and when it is turned left, rpm decreases.
(Refer to illustration.)

Normal idling rpm	3100 ± 1000 rpm
-------------------	-----------------

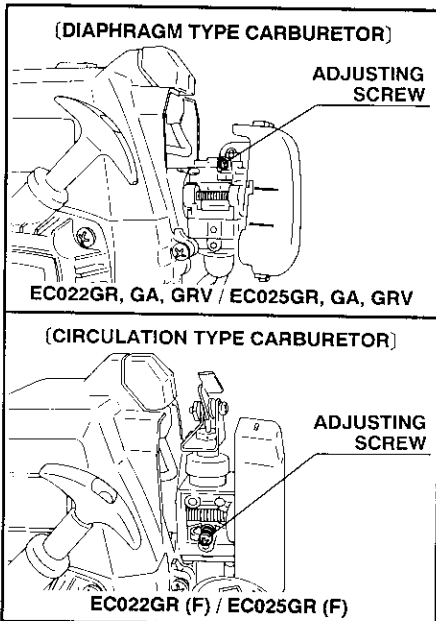

NOTE :

The carburetor greatly affects the performance of the engine. Since it has been adjusted carefully at our factory before shipment, avoid adjusting unless absolutely necessary. If adjustments are needed, contact your nearest dealer.

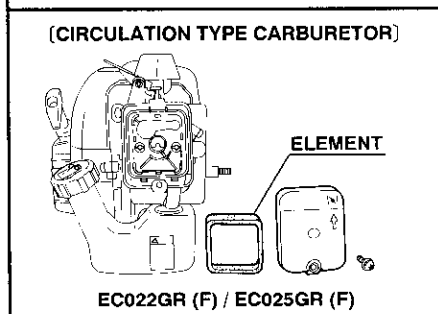
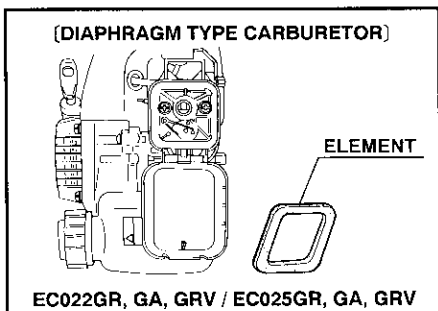

CLEANING AIR FILTER

- If your air cleaner elements is dirty, this will cause engine starting trouble, power loss, engine malfunctions, and extremely shorten engine life. Keep the air cleaner element clean.
- Remove the element and wash it in kerosene or diesel fuel. Then saturate it in a mixture of 3 parts kerosene or diesel fuel and 1 part engine oil. Squeeze out the excess and install the element.

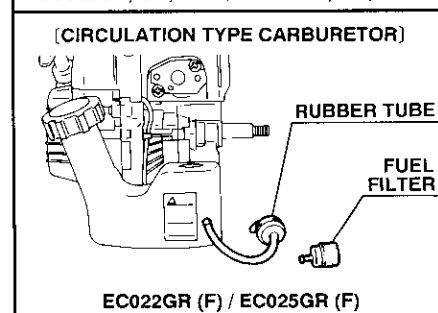
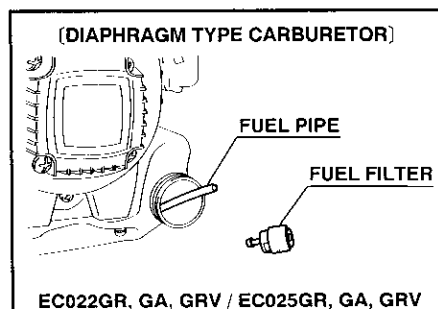

CLEANING FUEL FILTER

- Remove the fuel filter clip and pull the retainer, packing and felt out of the body.
- Wash the body and secondary filter in the form of one unit with kerosene. Wash the felt with kerosene. After washing, reassemble them.

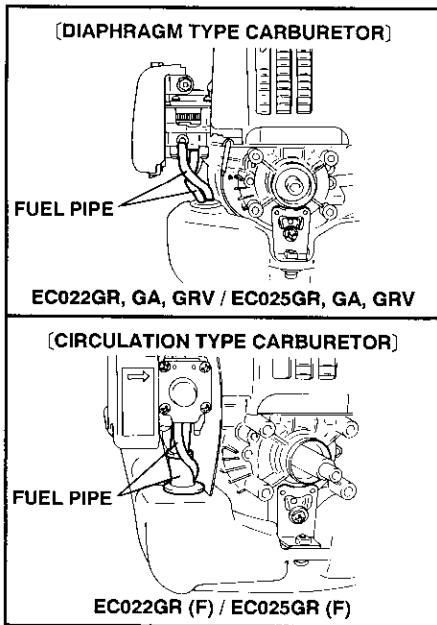

FUEL PIPE REPLACEMENT

Replace the fuel pipe every 2 years.
If the fuel leakage is found on the fuel pipe, replace it immediately.

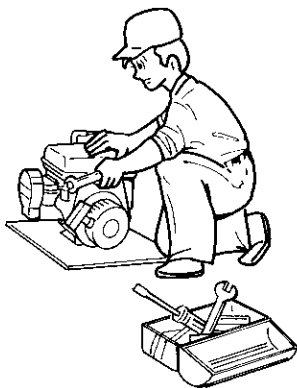

CHECKING BOLTS, NUTS AND SCREWS

Retighten loose bolts and nuts.
Check for fuel and oil leaks.
Replace damaged parts with new ones.
Keep safety in your mind.

8. PREPARATIONS FOR STORAGE

DISCHARGE FUEL (NO SMOKING !)

In case the engine is not going to be used for more than one month, discharge fuel thoroughly from fuel tank and carburetor in order to prevent from hard starting and/or poor engine operation due to deteriorated fuel when you use the engine next time.

- Pour out the fuel in the tank from its filler neck.
- Push the primer button of the carburetor until the fuel in it is thoroughly discharged.



OIL

- Remove the spark plug, pour about 2 cc engine oil into the cylinder, slowly pull the starter handle of the recoil starter 2 or 3 times, and tighten the spark plug.



CLEAN AND STORE

- Slowly pull the recoil starter handle until resistance is felt and leave it in that position.
- Clean the engine thoroughly with an oiled cloth, put the cover on and store the engine indoors in a well-ventilated, low humidity area.

9. SPECIFICATIONS

MODEL	EC022GR	EC022GA	EC022GR(F)	EC022GRV	EC025GR	EC025GA	EC025GR(F)	EC025GRV	
Type	Air-cooled, 2-cycle, Single cylinder, Gasoline engine								
P.T.O. Shaft	Horizontal STD.	Horizontal Fan cover side	Horizontal STD.	Vertical	Horizontal STD.	Horizontal Fan cover side	Horizontal STD.	Vertical	
Displacement	21.7 cm ³				24.5 cm ³				
Continuous Output	0.48 KW / 6000 rpm (0.65 HP / 6000 rpm)				0.55 KW / 6000 rpm (0.75 HP / 6000 rpm)				
Maximum Output	0.74 KW / 7000 rpm (1.0 HP / 7000 rpm)				0.88 KW / 7000 rpm (1.2 HP / 7000 rpm)				
P.T.O. Shaft Rotation	Counter-clockwise facing P.T.O. shaft								
Lubricant	2 cycle motor oil for mixture fuel								
Fuel	Oil mixed gasoline (Automobile gasoline (25 : 1 Lubricant))								
Fuel Tank Capacity	0.6 liter								
Carburetor	Diaphragm type		Circulation type	Diaphragm type	Diaphragm type		Circulation type	Diaphragm type	
Spark Plug	NGK BM7A (CHAMPION CJ4, CJ6)								
Starting System	Recoil starter								
Dry Weight	2.0 kg	2.2 kg	2.1 kg	2.0 kg	2.0 kg	2.2 kg	2.1 kg	2.0 kg	
Dimensions	Length	152 mm	153 mm	179 mm	152 mm	152 mm	153 mm	179 mm	152 mm
	Width	212 mm	207 mm	212 mm	226 mm	212 mm	207 mm	212 mm	226 mm
	Height	210 mm	218 mm	214 mm	221 mm	210 mm	218 mm	214 mm	221 mm