

Robin Generator

Model **RG3200IS**
for CANADA

PARTS CATALOG

Spec. No. RAS32023541
(EX210DS2040)

FUJI HEAVY INDUSTRIES LTD.

ISSUE EMD-GP6343	
ISSUE DATE	2006.10

FIG. 100

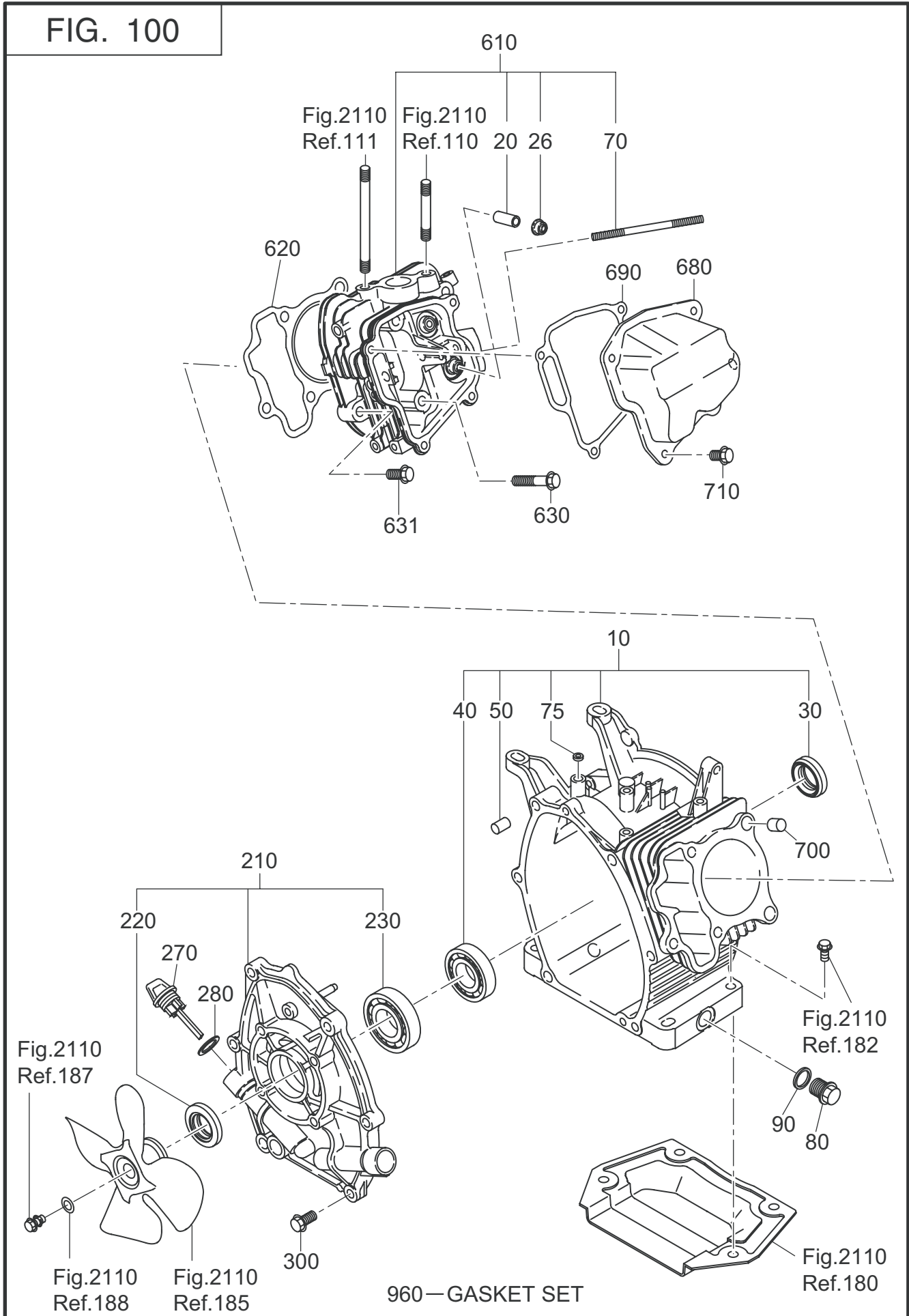

FIG. 200

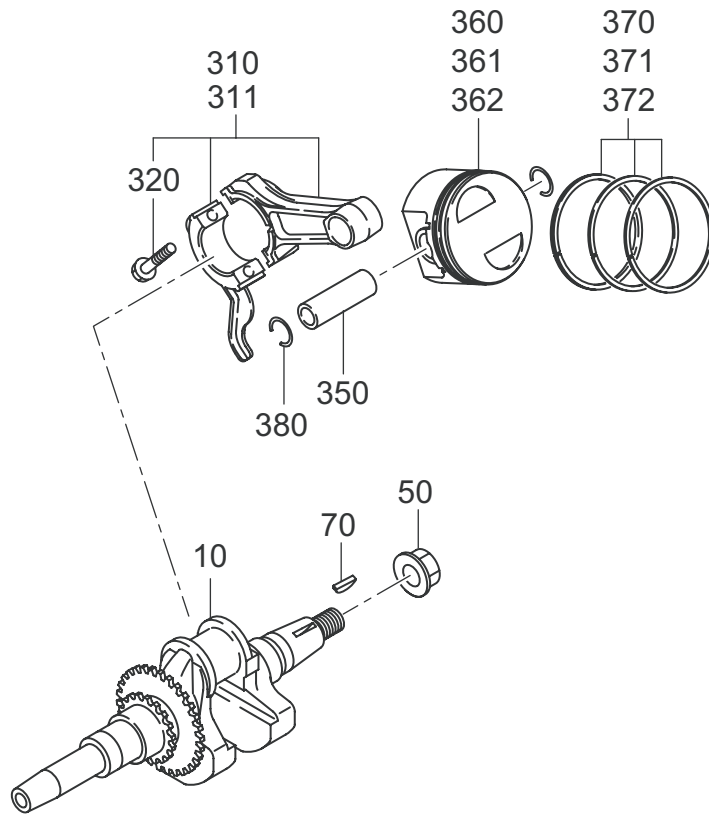

FIG. 300

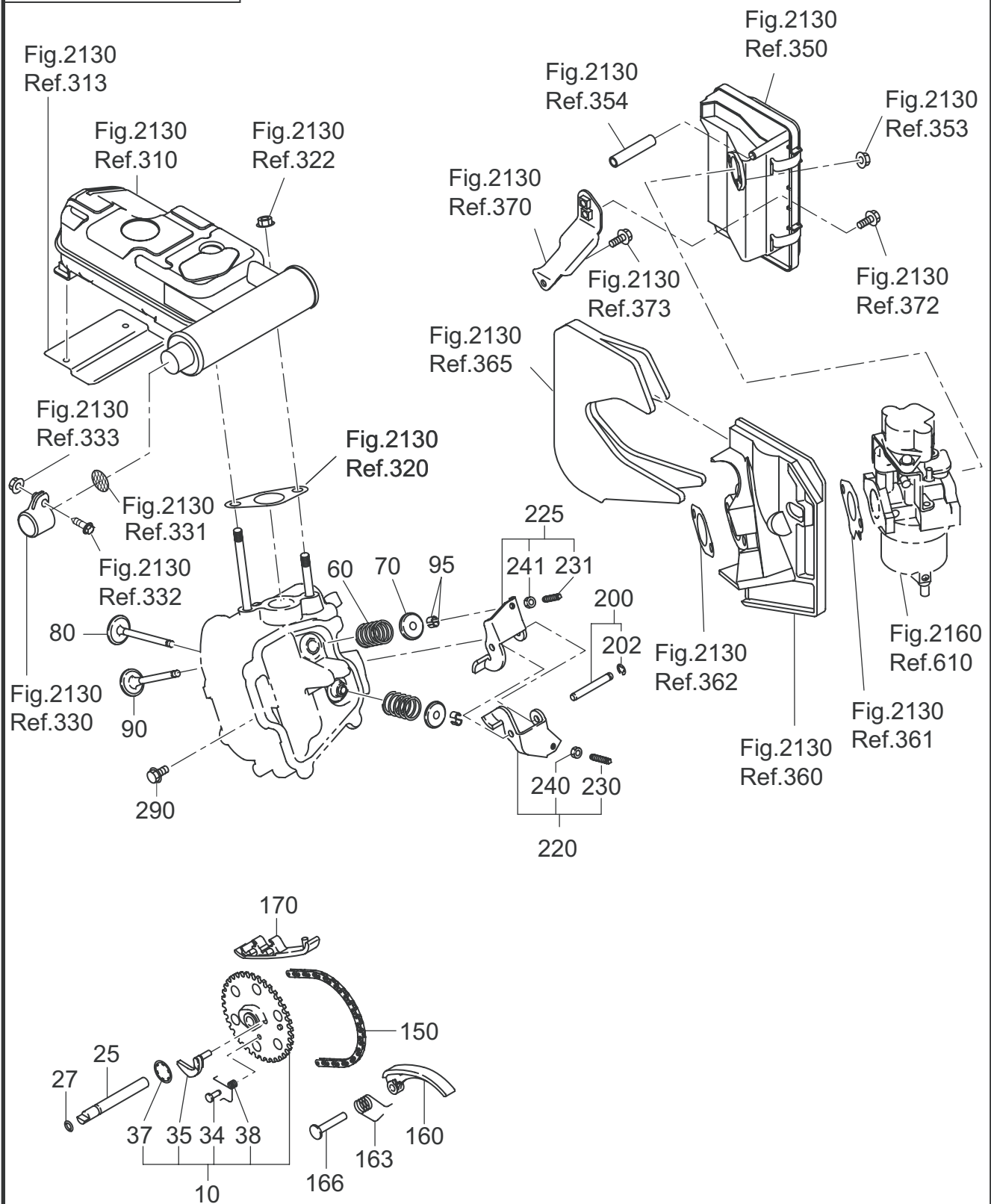

FIG. 400

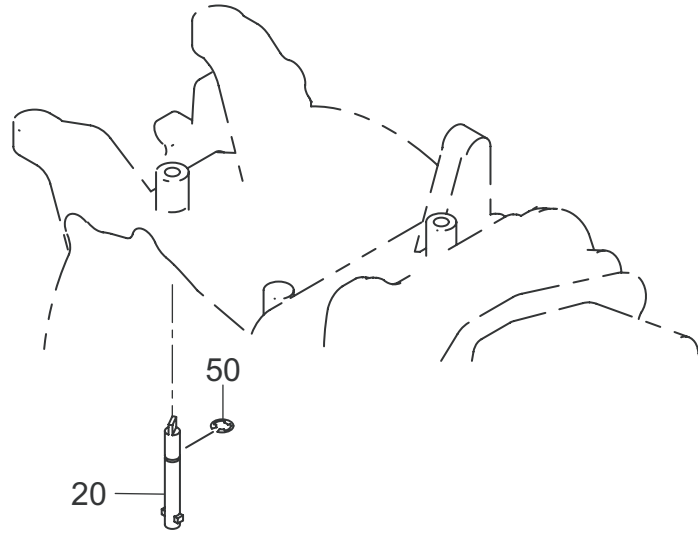

FIG. 500

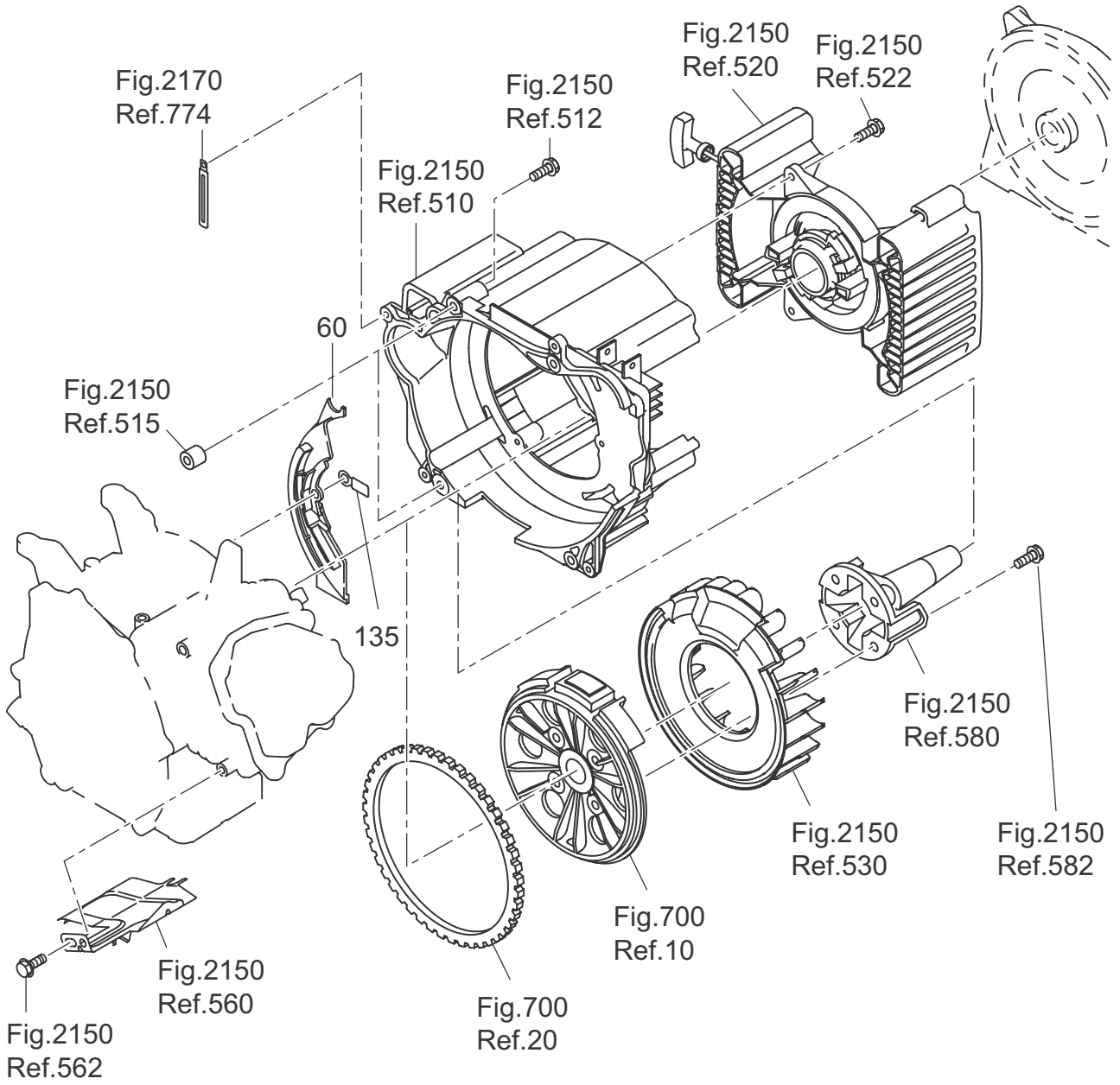

FIG. 700

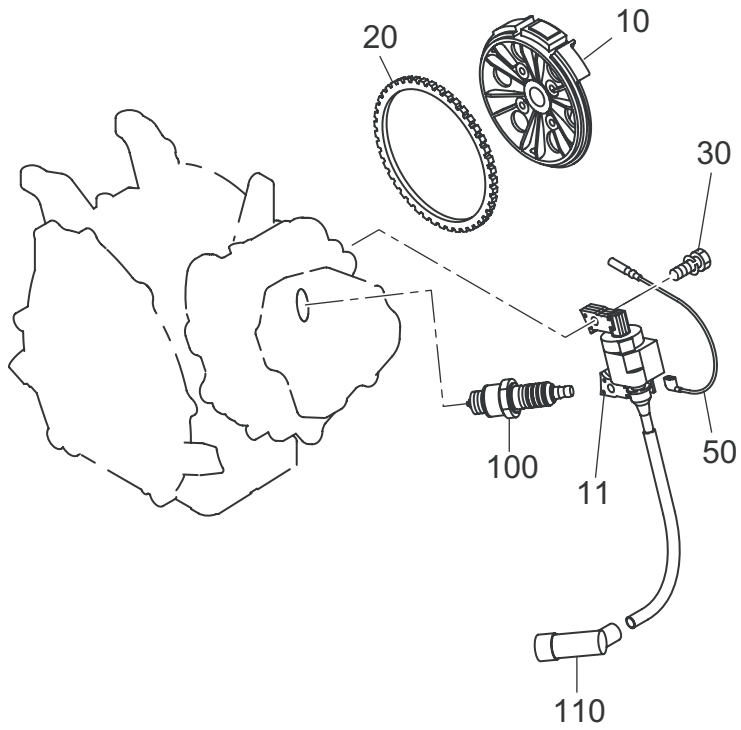

FIG. 720

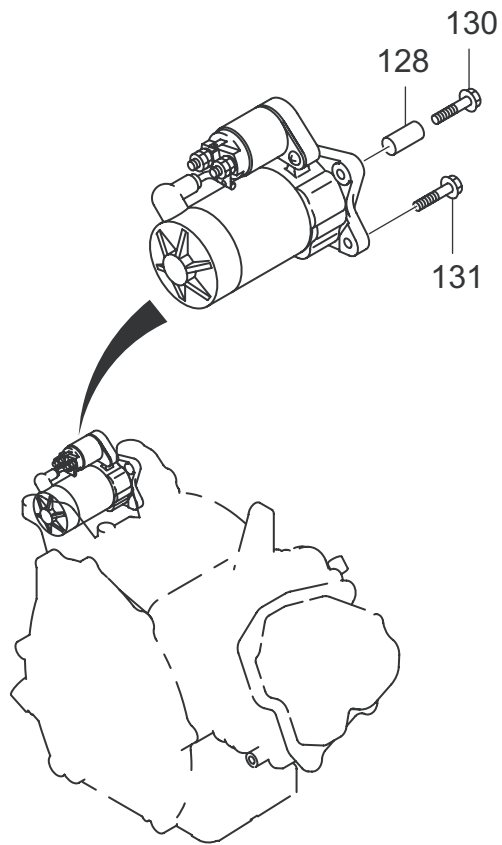

FIG. 730

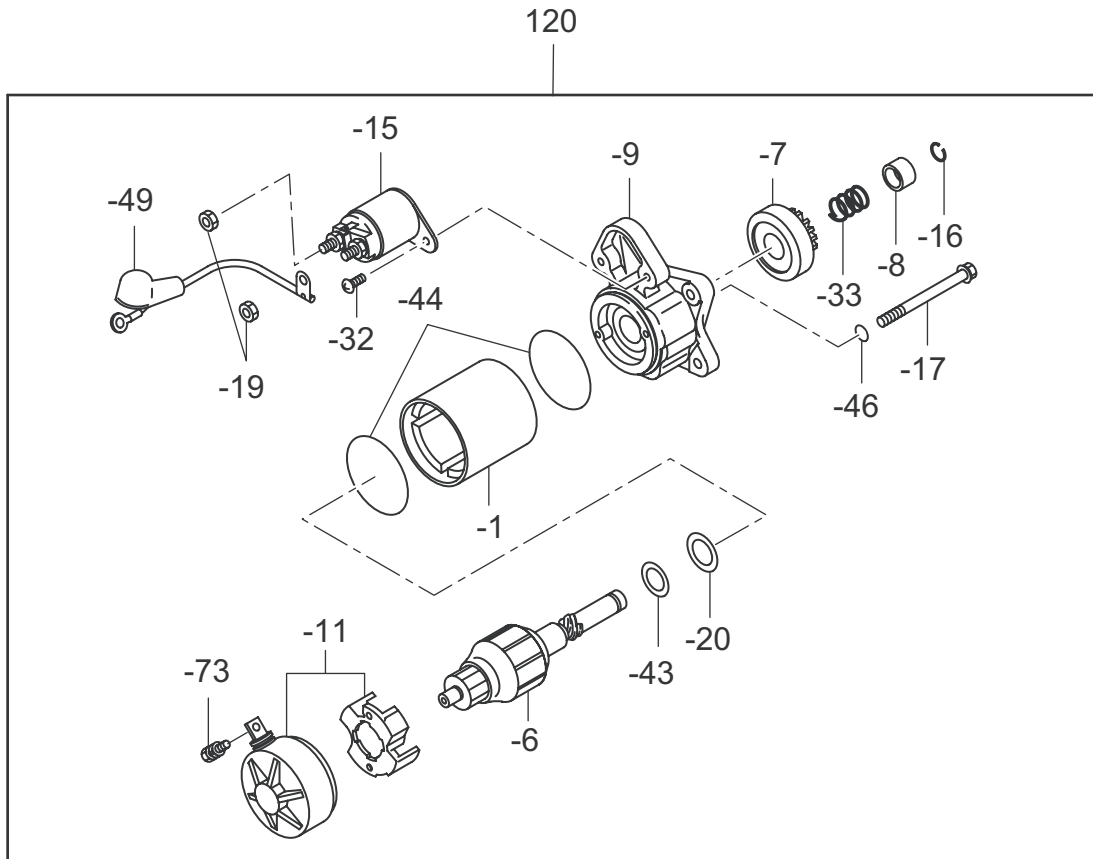

FIG. 770

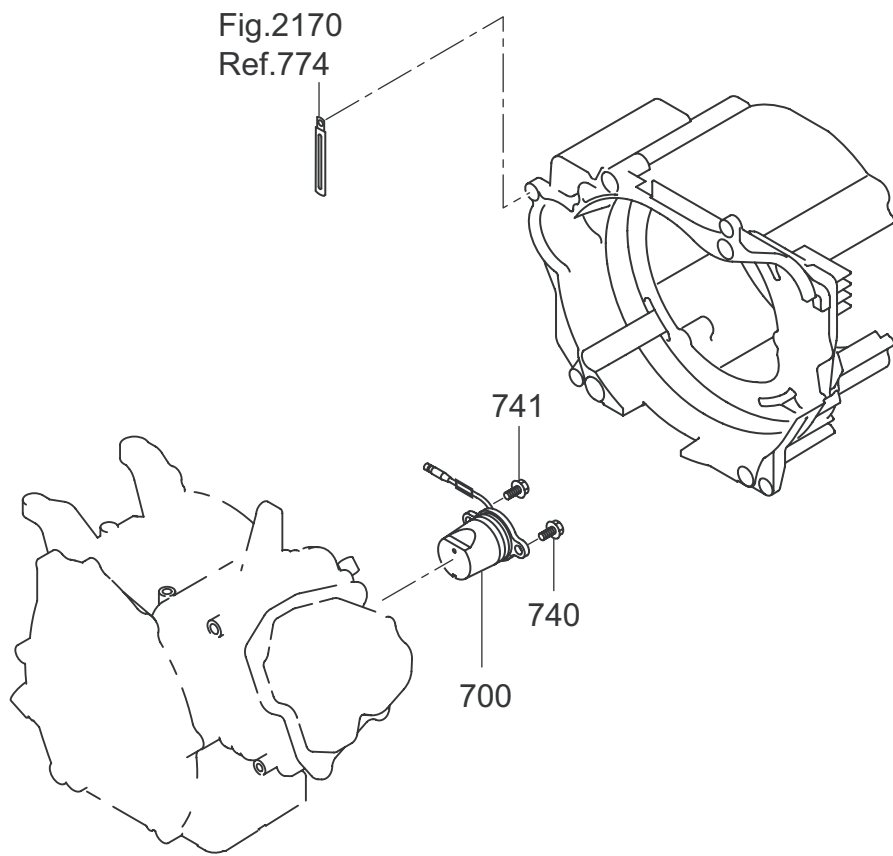

FIG. 2110

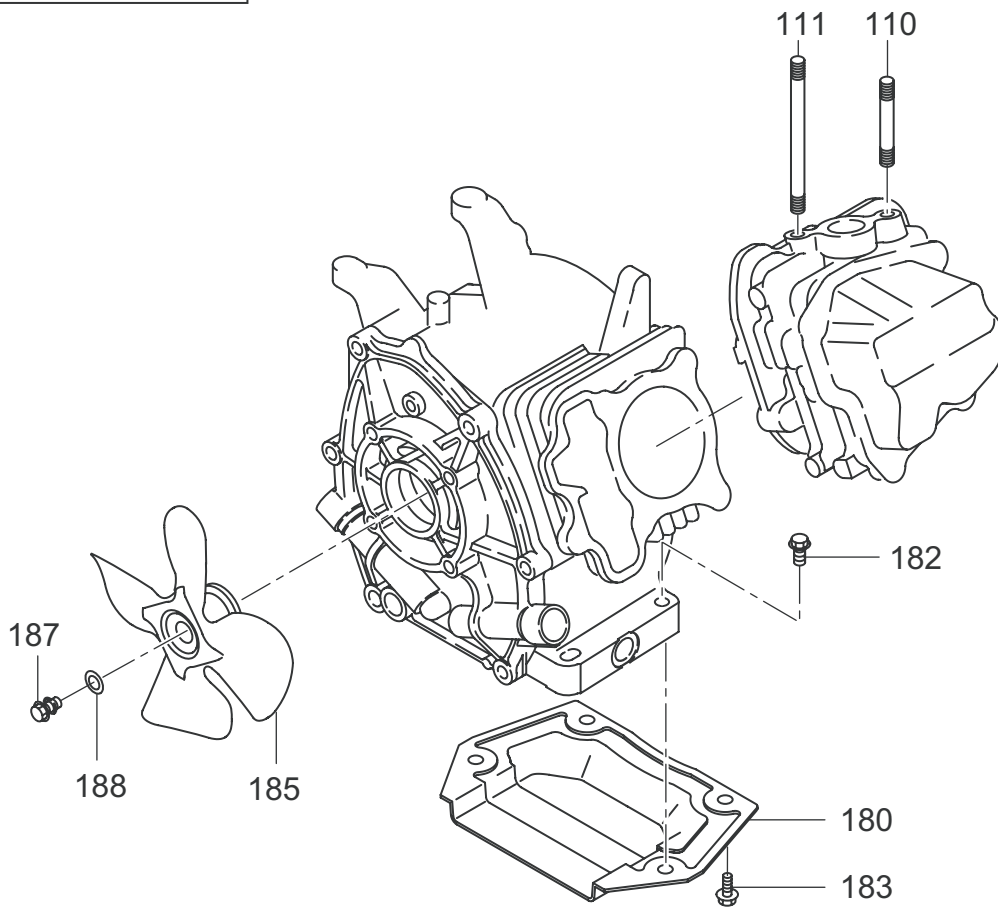

FIG. 2130

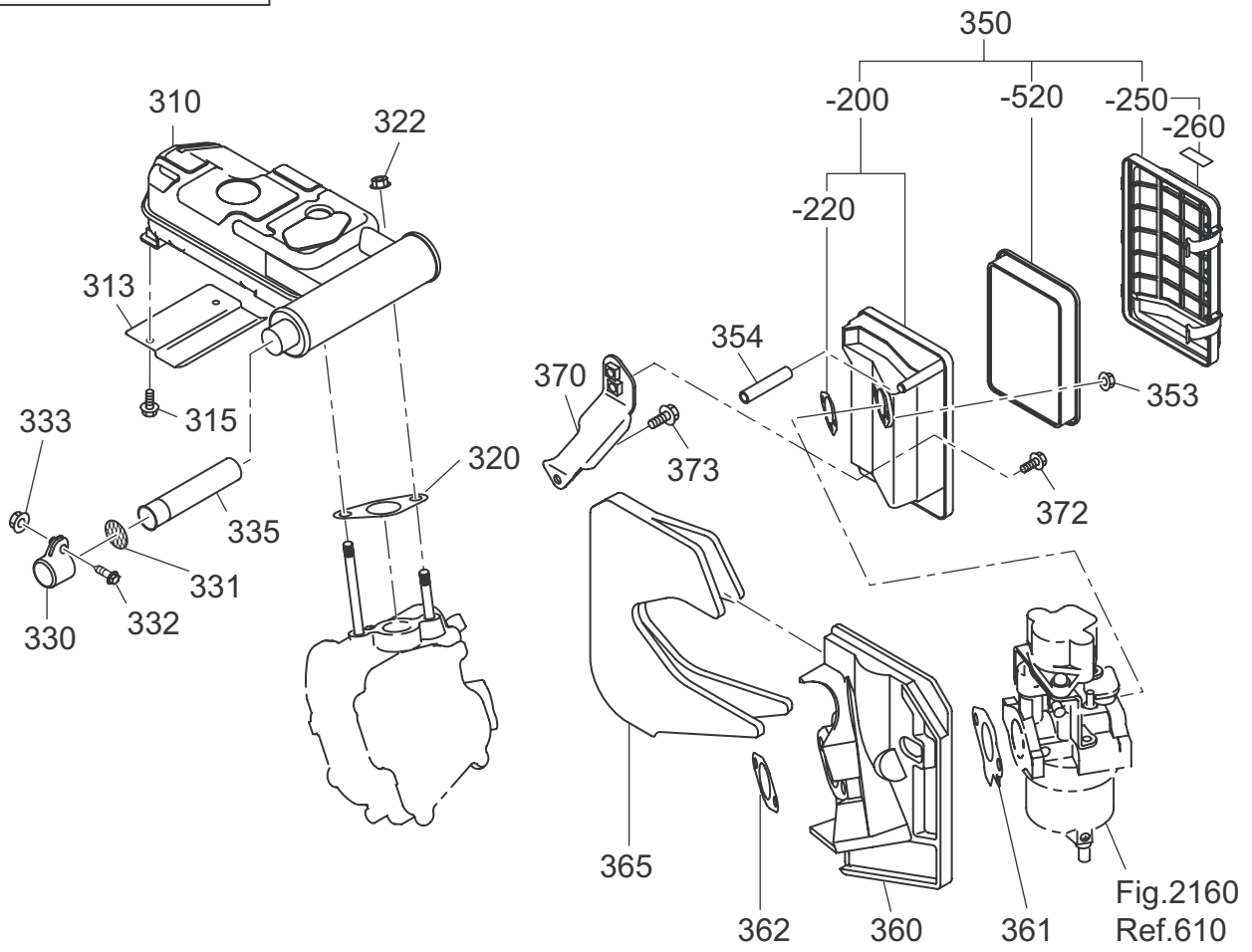

FIG. 2150

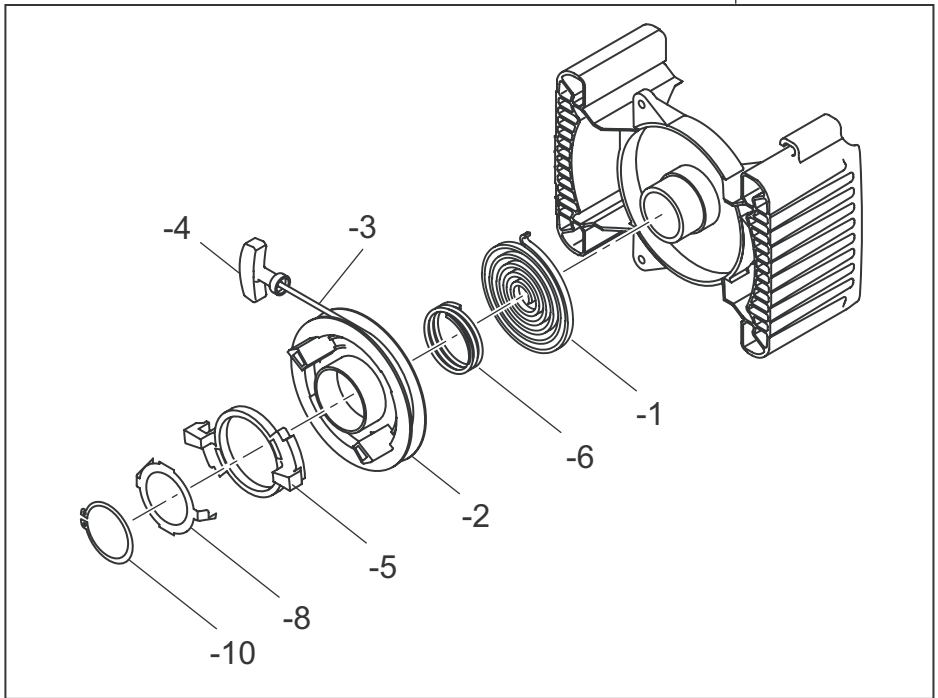
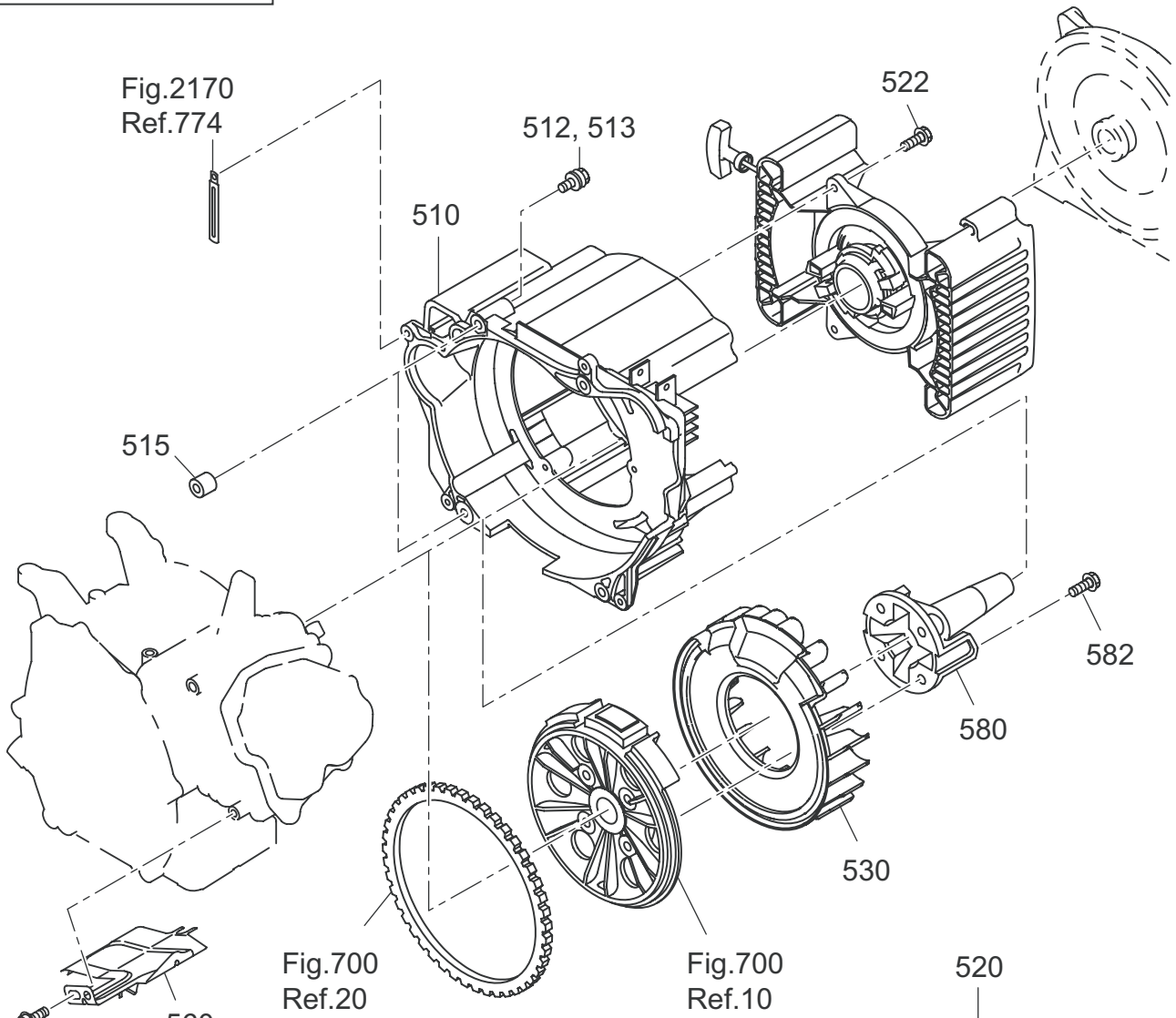

FIG. 2160

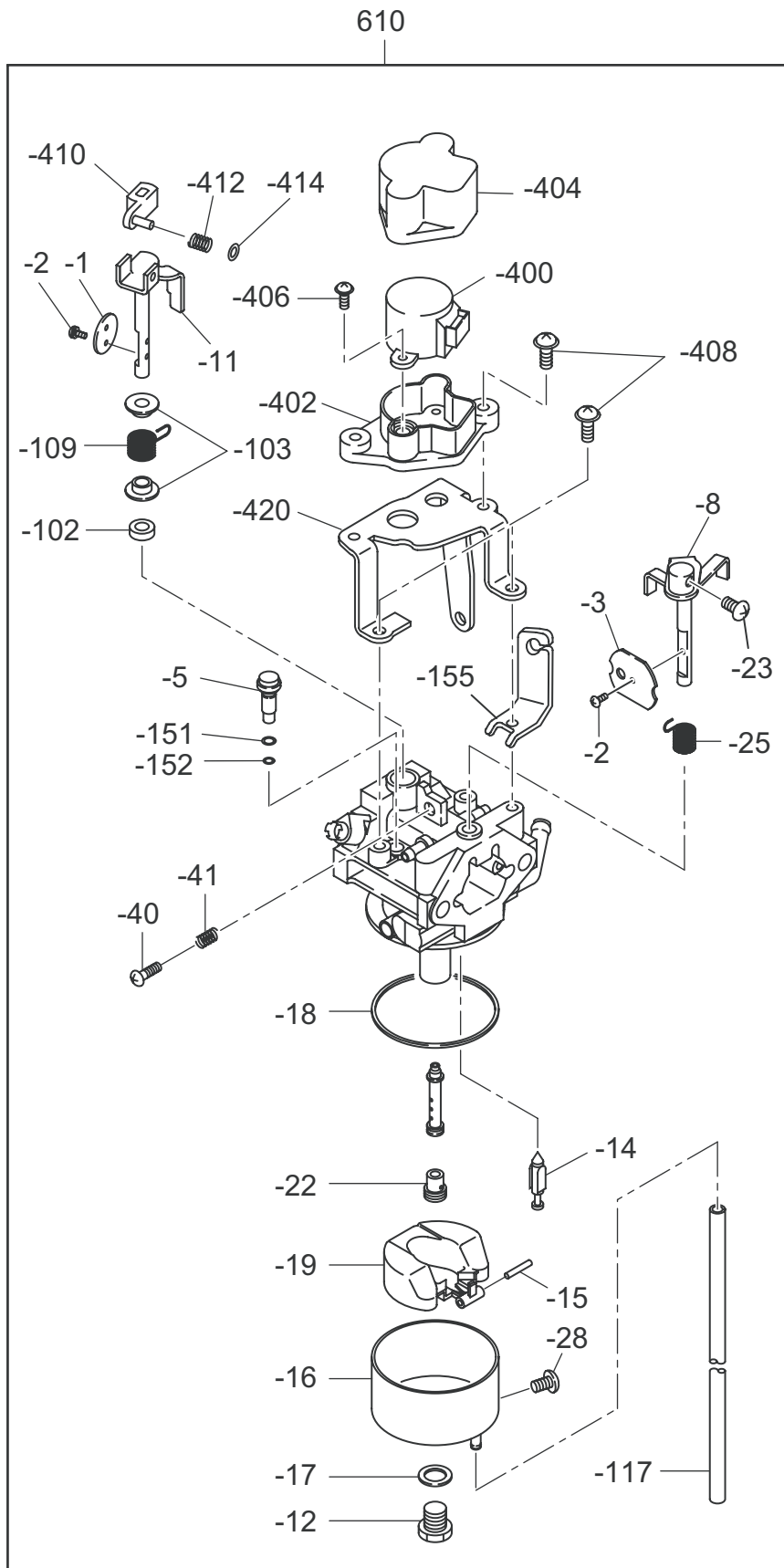

FIG. 2170

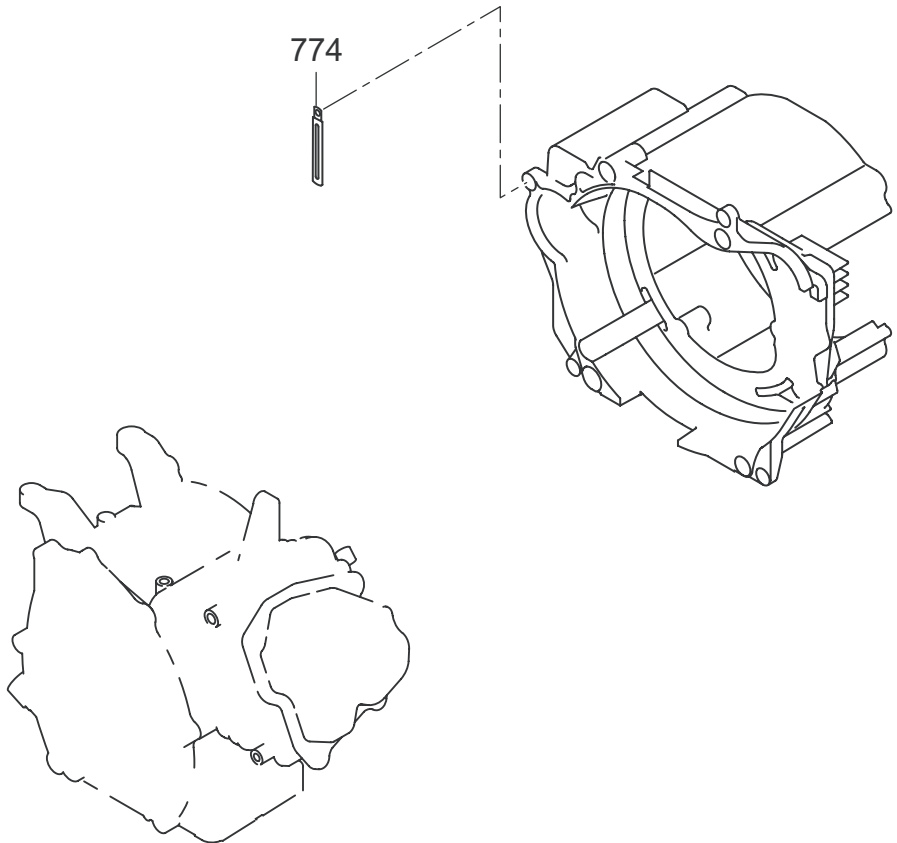

FIG. 2200

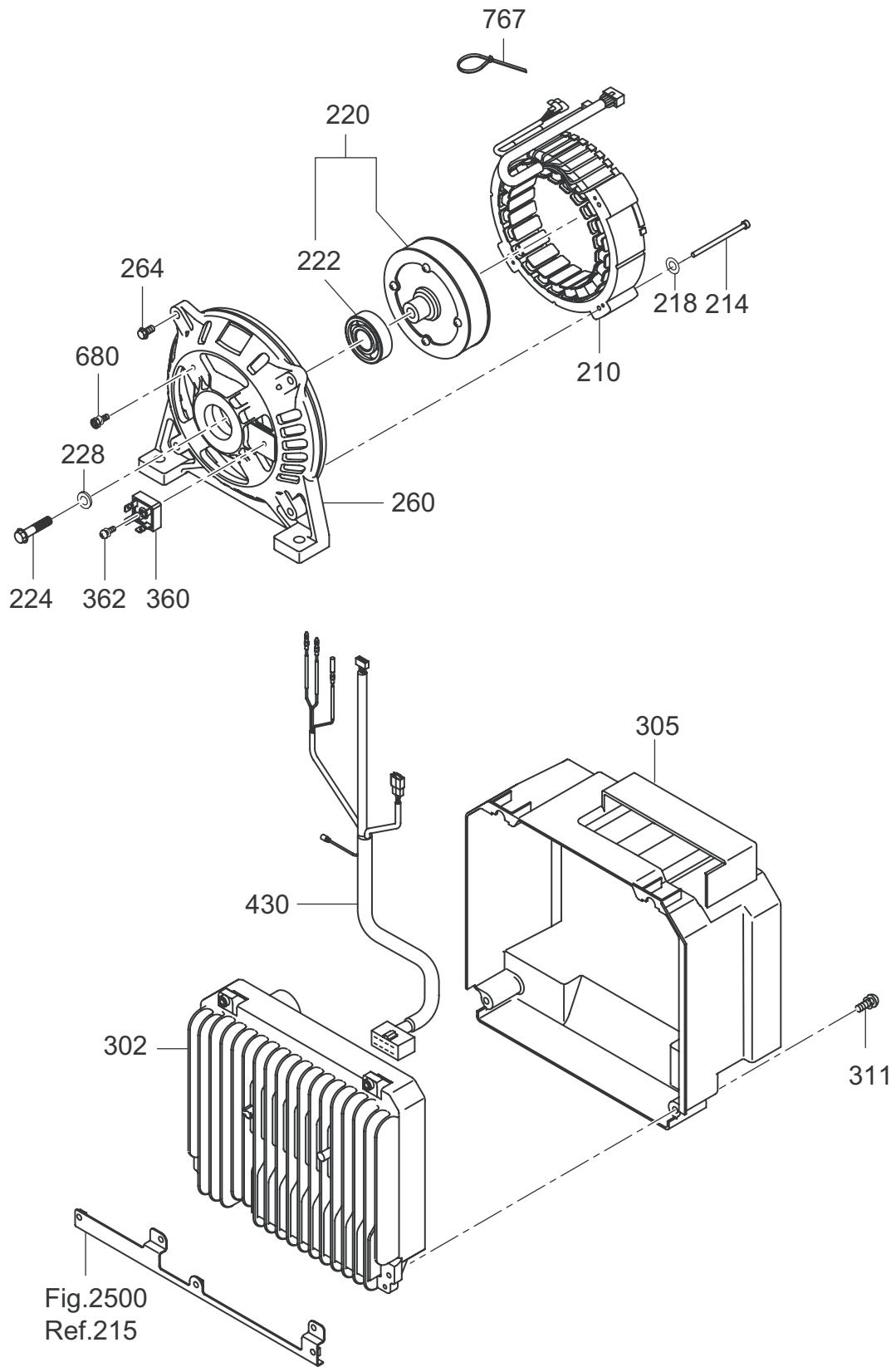

FIG. 2300

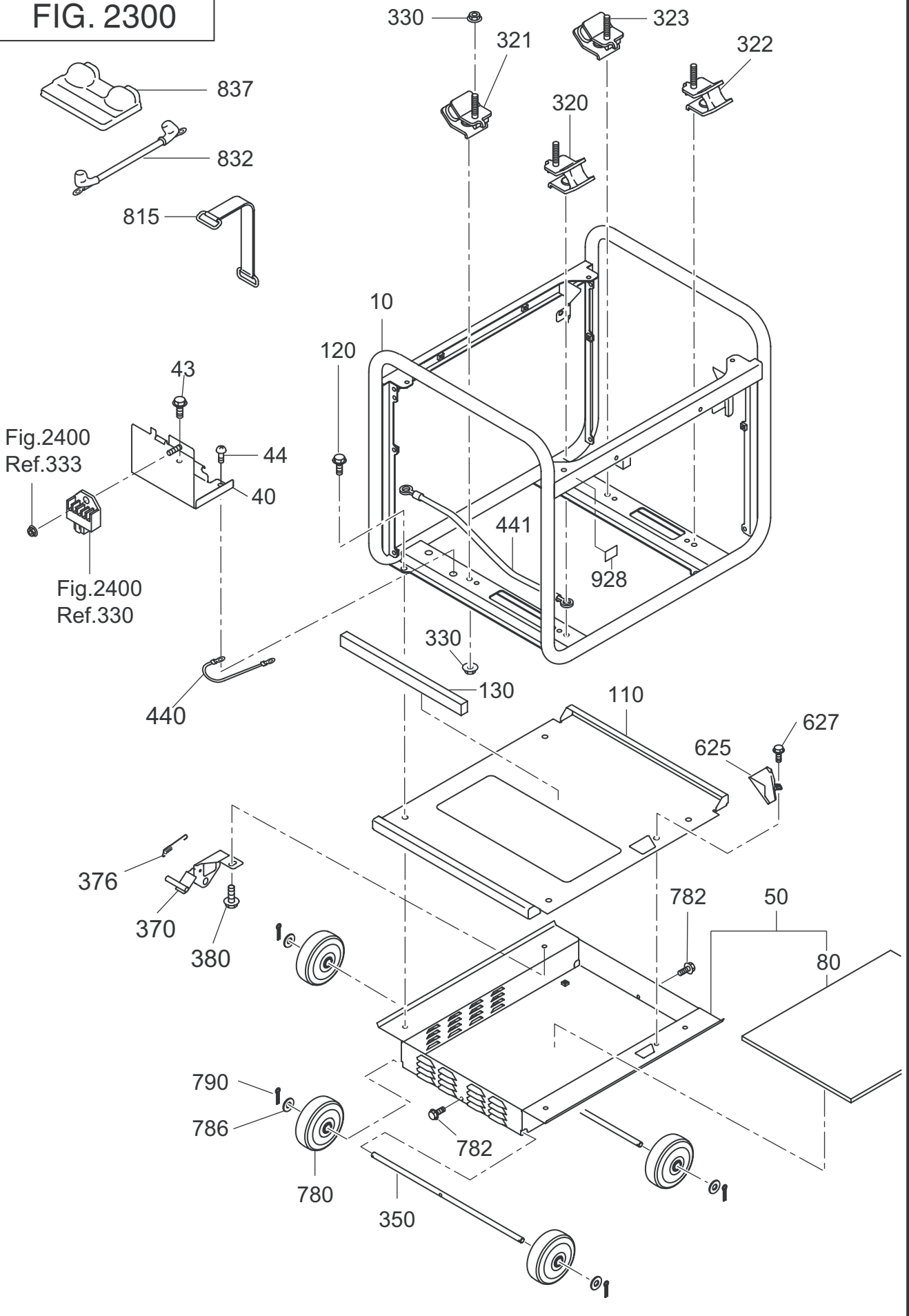
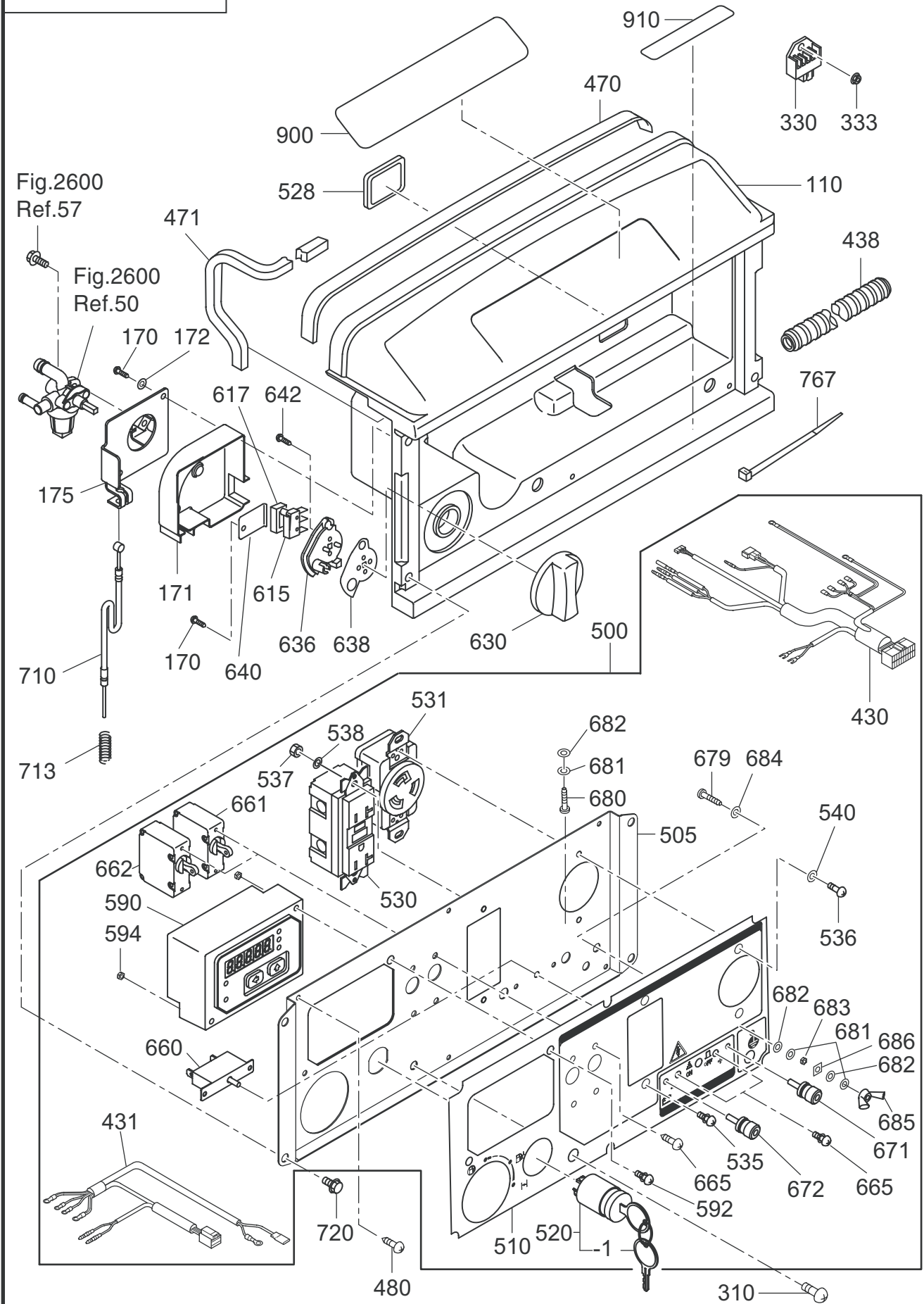

FIG. 2400



24 CONTROL

REF.	PART NUMBER	PART NAME	QTY	R E M A R K S	CODE NO.	INTERCHANGE P/NO.	UNIT P	FIG.
110	33B-50001-01	FRONT COVER(UPPER)CP	1		-			2400
170	015-00400-70	TAPPING SCREW	3	M4X20L	-			2400
171	33B-46001-03	COVER(COCK)	1		-			2400
172	003-10040-00	WASHER	2		-			2400
175	33B-46012-11	BRACKET(COCK)	1		-			2400
310	004-36061-60	SCREW AND WASHER AY	2	M6X1.0X16L W/W, SW	-			2400
330	33B-47203-01	REGULATOR CP	1		-			2400
333	002-38060-00	FLANGE NUT	1	M6X1.0X13DX6H	-			2400
430	33B-48061-21	WIRE HARNESS CP	1		-			2400
431	34B-48005-01	WIRE HARNESS CP	1		-			2400
438	34H-49001-03	CORRUGATED TUBE	1		-			2400
470	34B-57311-03	SEAL SPONGE FC2	1		-			2400
471	34G-47001-03	SEAL SPONGE(C.BOX 1)	1		-			2400
480	353-49904-08	TAPPING SCREW	6		-			2400
500	34C-45C21-20	CONTROL PANEL AY	1		-			2400
505	33B-45018-01	PANEL PLATE CP	1		-			2400
510	34B-49134-03	SHEET(PANEL VS)34	1		-			2400
520	066-00003-30	SWITCH	1		-			2400
- 1	066-00099-80	KEY, SWITCH	2	MARK 103	-			2400
528	227-75001-03	GROMMET	1		-			2400
530	388-85003-01	AC RECEPTACLE	1	125V-20A	-			2400
531	356-45711-08	AC RECEPTACLE	1	125V-30A	-			2400
535	004-35041-00	SCREW AND WASHER AY	2		-			2400
536	356-59937-08	SCREW	2		-			2400
537	002-27040-00	NUT	2		-			2400
538	003-10040-00	WASHER	2		-			2400
540	326-00335-08	SPRING WASHER	2		-			2400
590	KU3-11760-11	MONITOR C/U CP(INV1)	1		-			2400
592	013-10400-80	SCREW AND WASHER AY	2		-			2400
594	002-17040-00	NUT	2		-			2400
615	33K-41811-03	MICRO SWITCH	1		-			2400
617	33D-46040-03	SPACER(SWITCH)	1		-			2400
630	33K-42010-03	CONTROL DIAL	1		-			2400
636	33K-42020-03	CHOKE REEL	1		-			2400
638	33K-42030-23	PLATE	1		-			2400
640	33B-46015-01	BRACKET(MICRO)	1		-			2400
642	33K-41814-08	TAPPING SCREW	2		-			2400
660	32B-43041-03	CIRCUIT BREAKER	1	DC 10A	-			2400
661	32B-43161-01	CIRCUIT BREAKER	1		-			2400
662	32B-43164-01	CIRCUIT BREAKER	1		-			2400

FIG. 2400

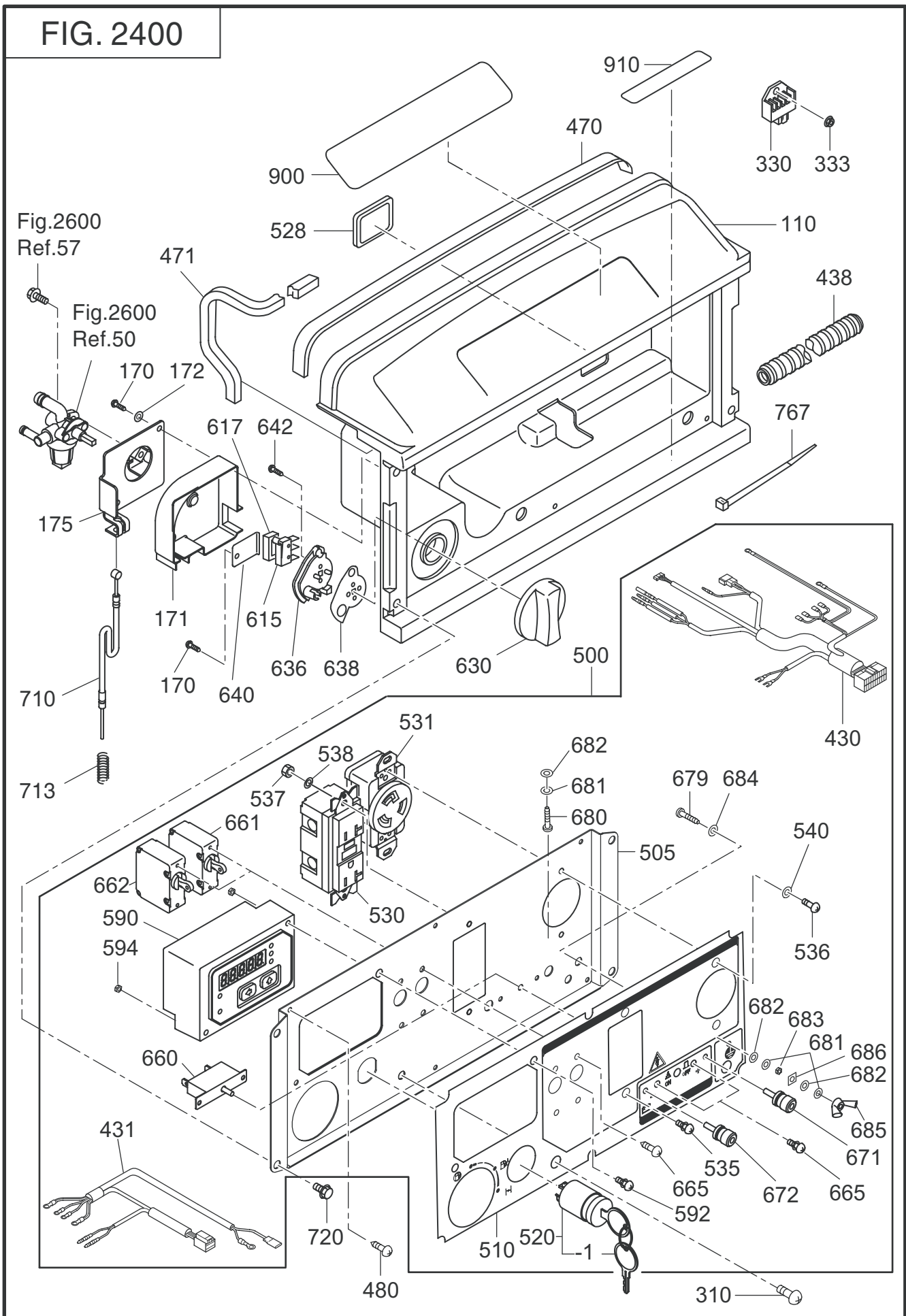

FIG. 2500

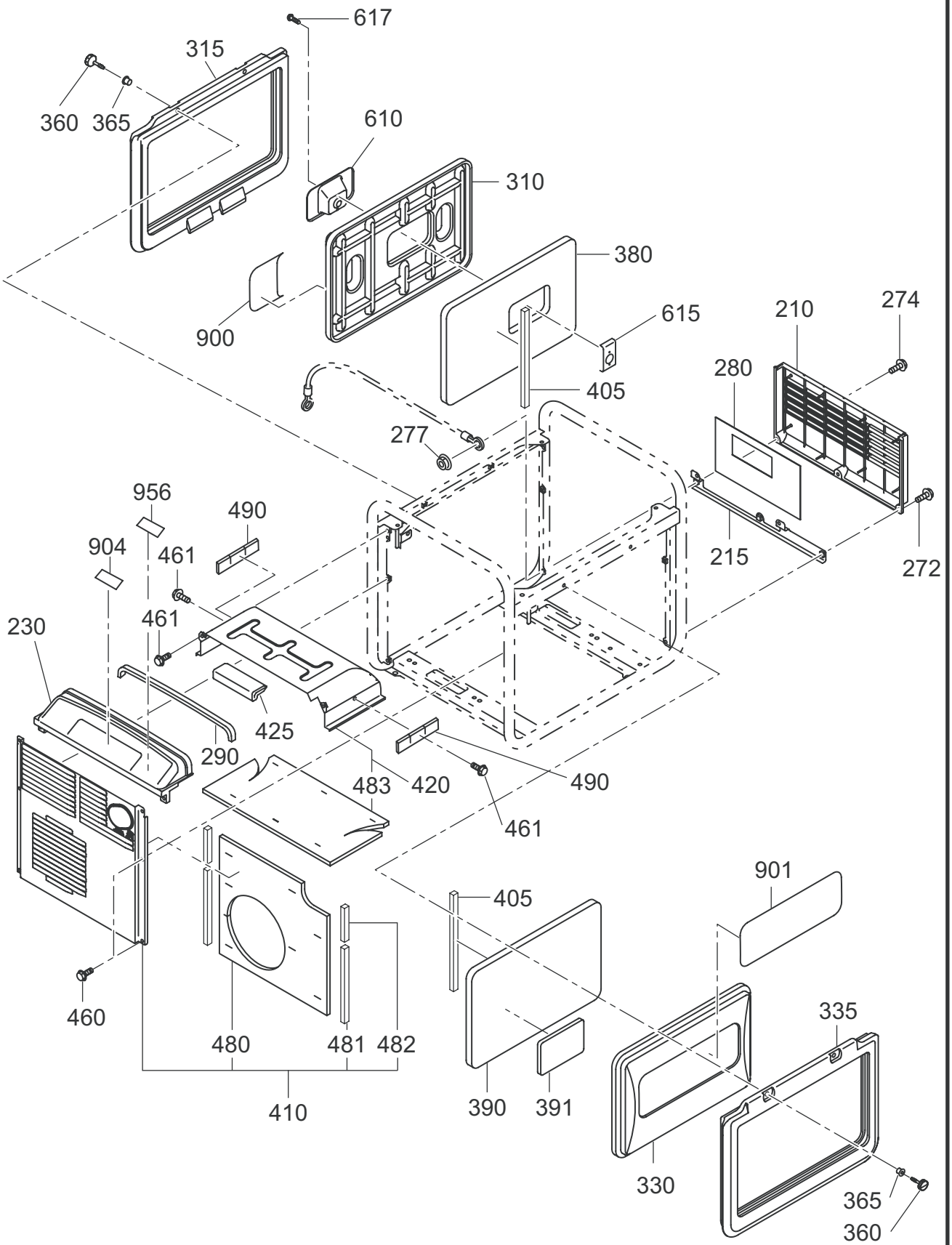

FIG. 2510

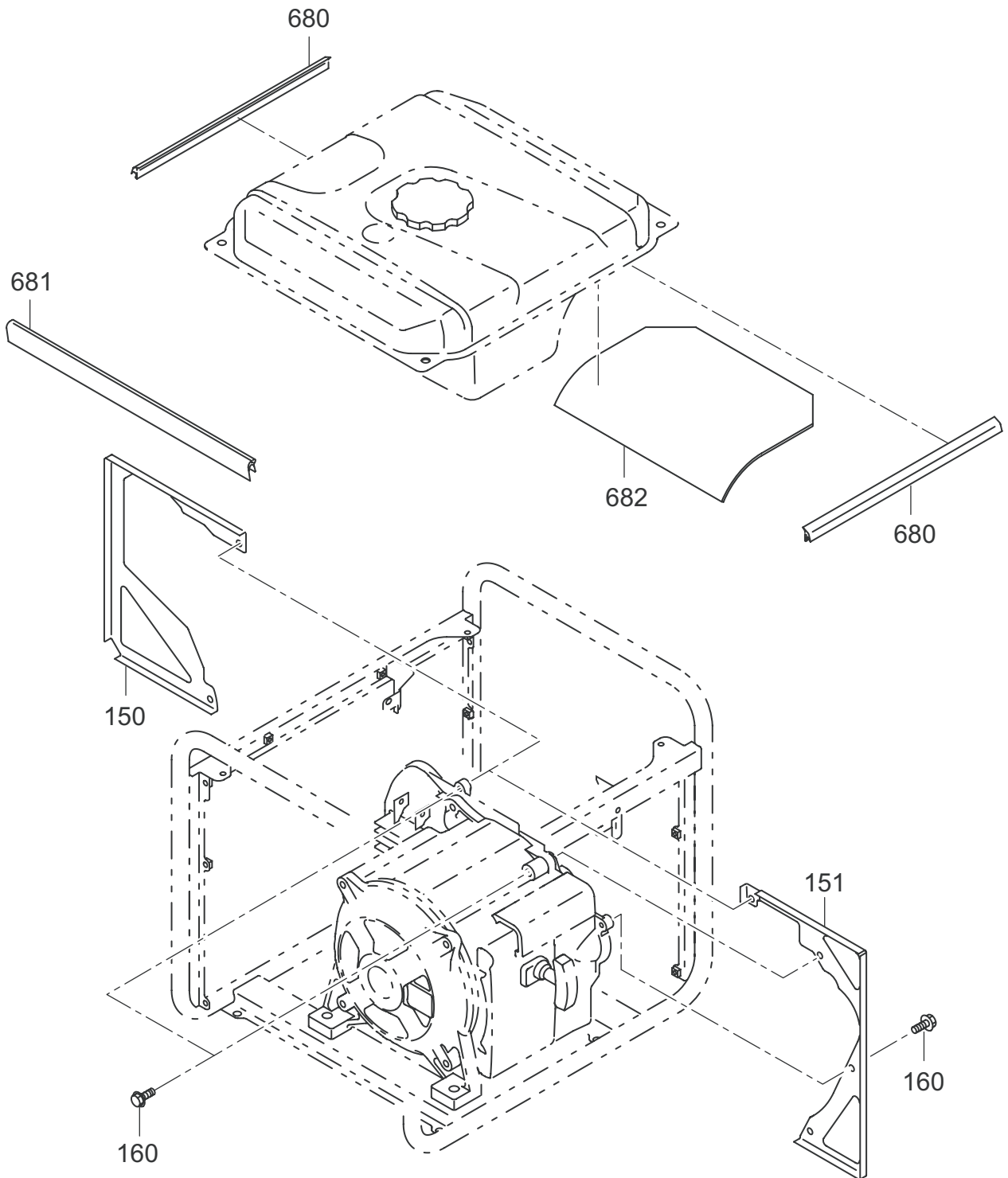

FIG. 2600

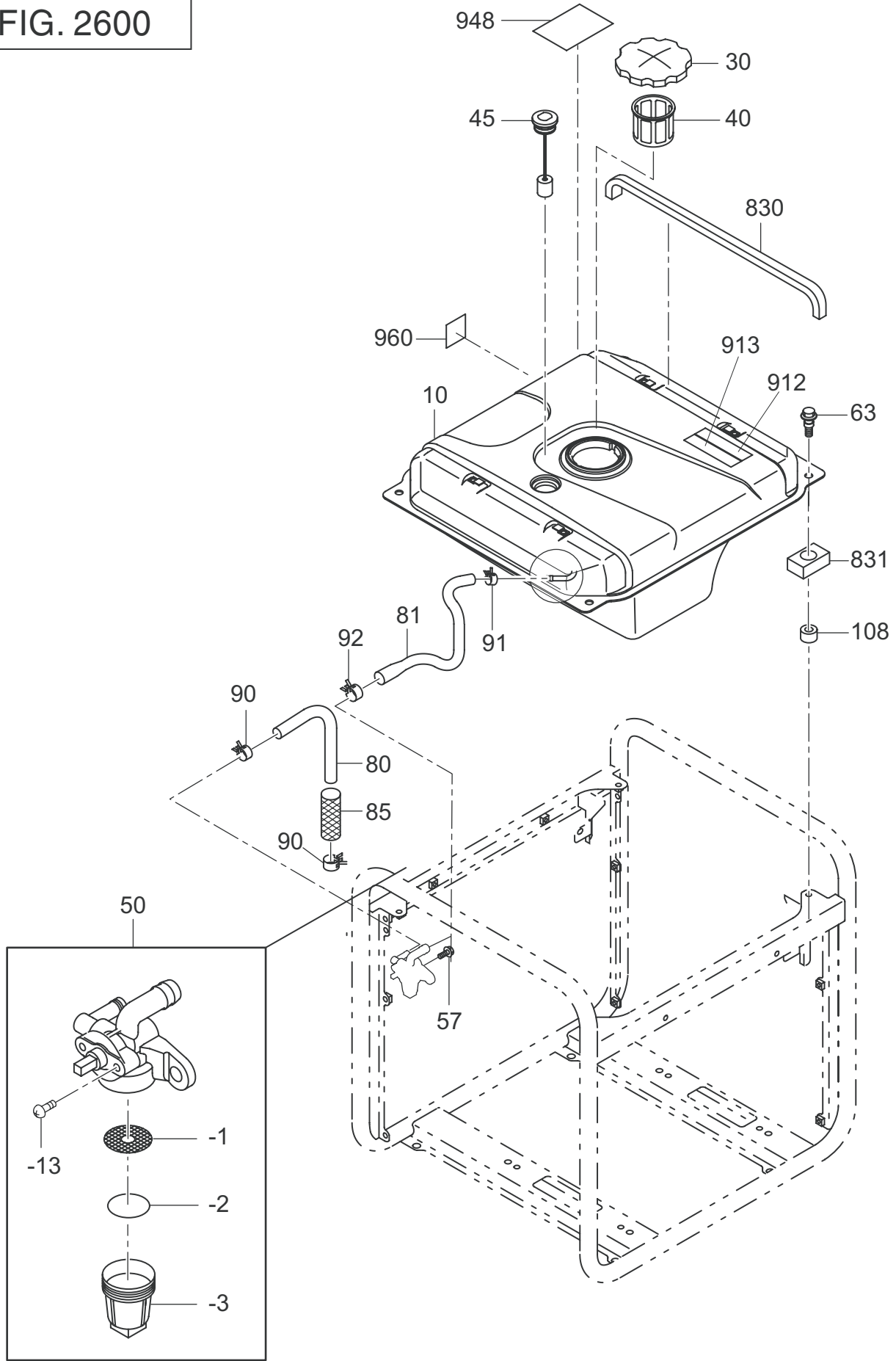

FIG. 2900

