

Model R650

PARTS CATALOG

Spec. No. RG006037060

Engine. EY080DN8190

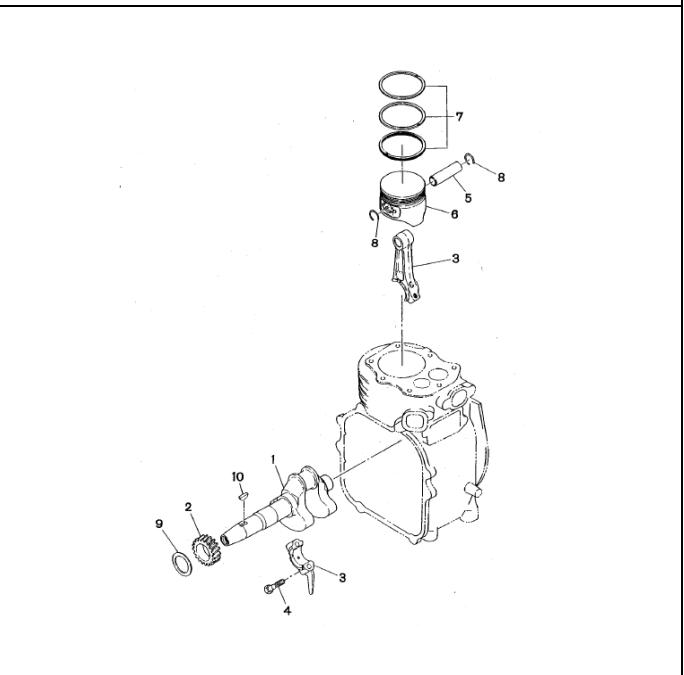
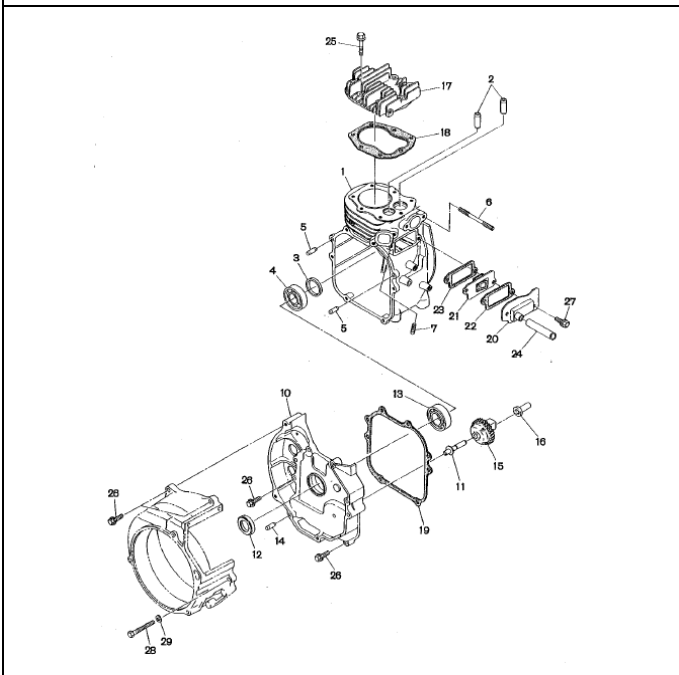
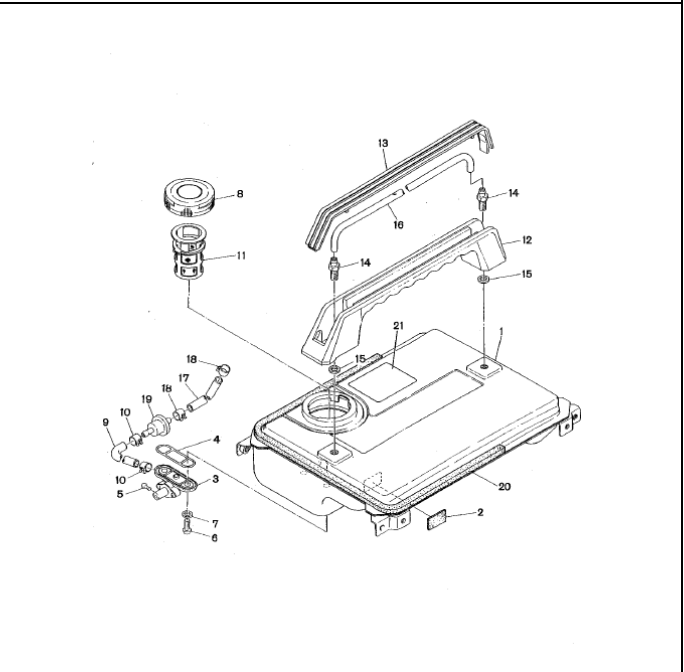
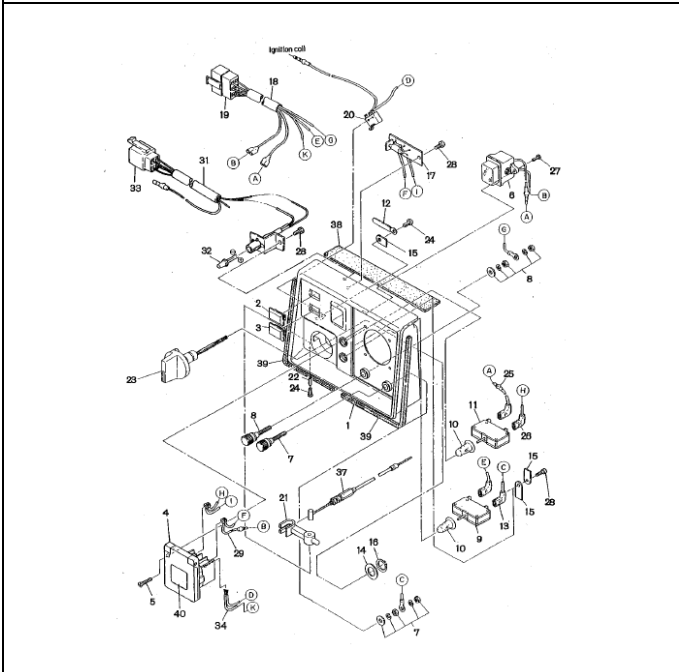
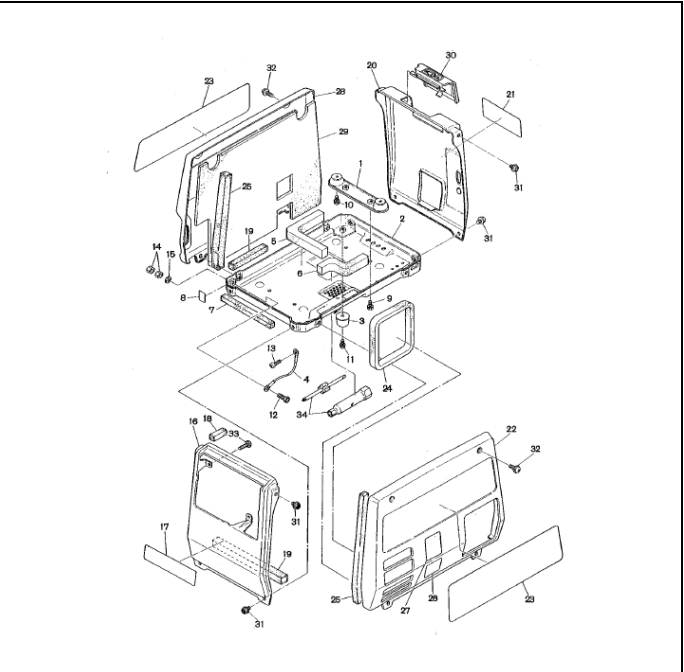
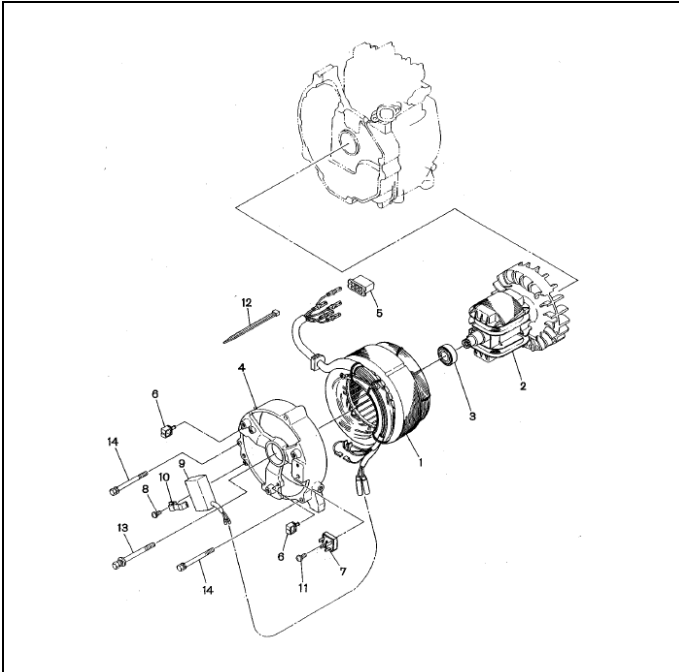

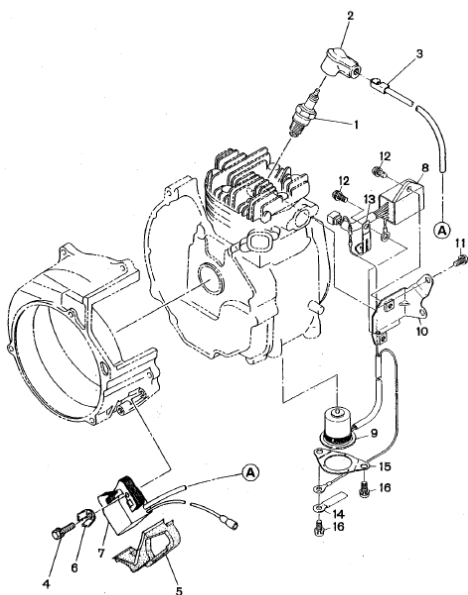
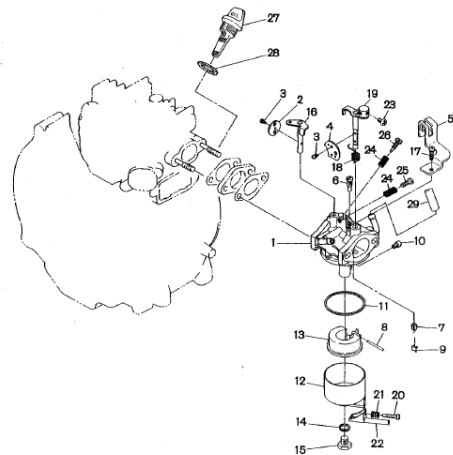
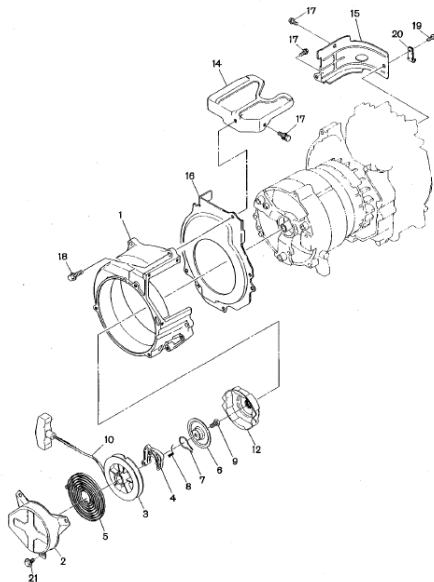
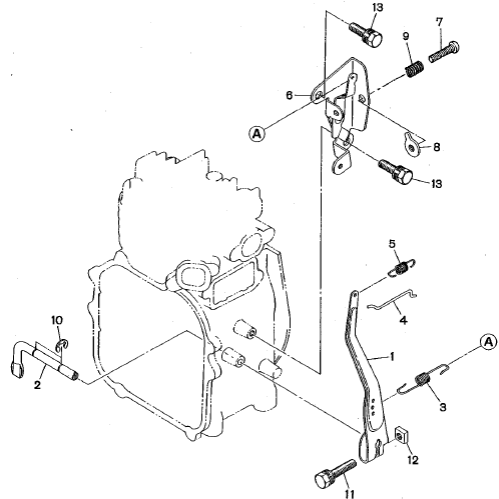
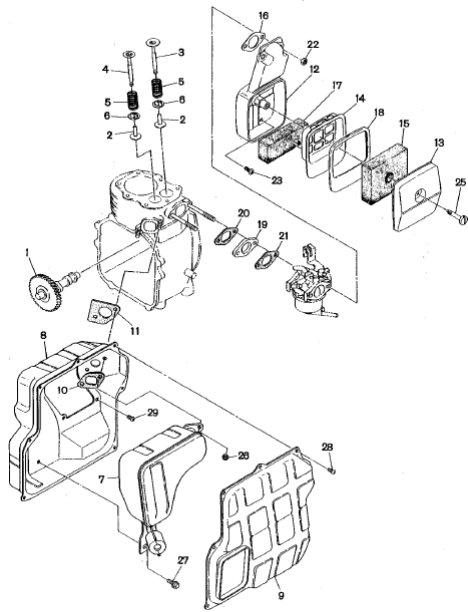
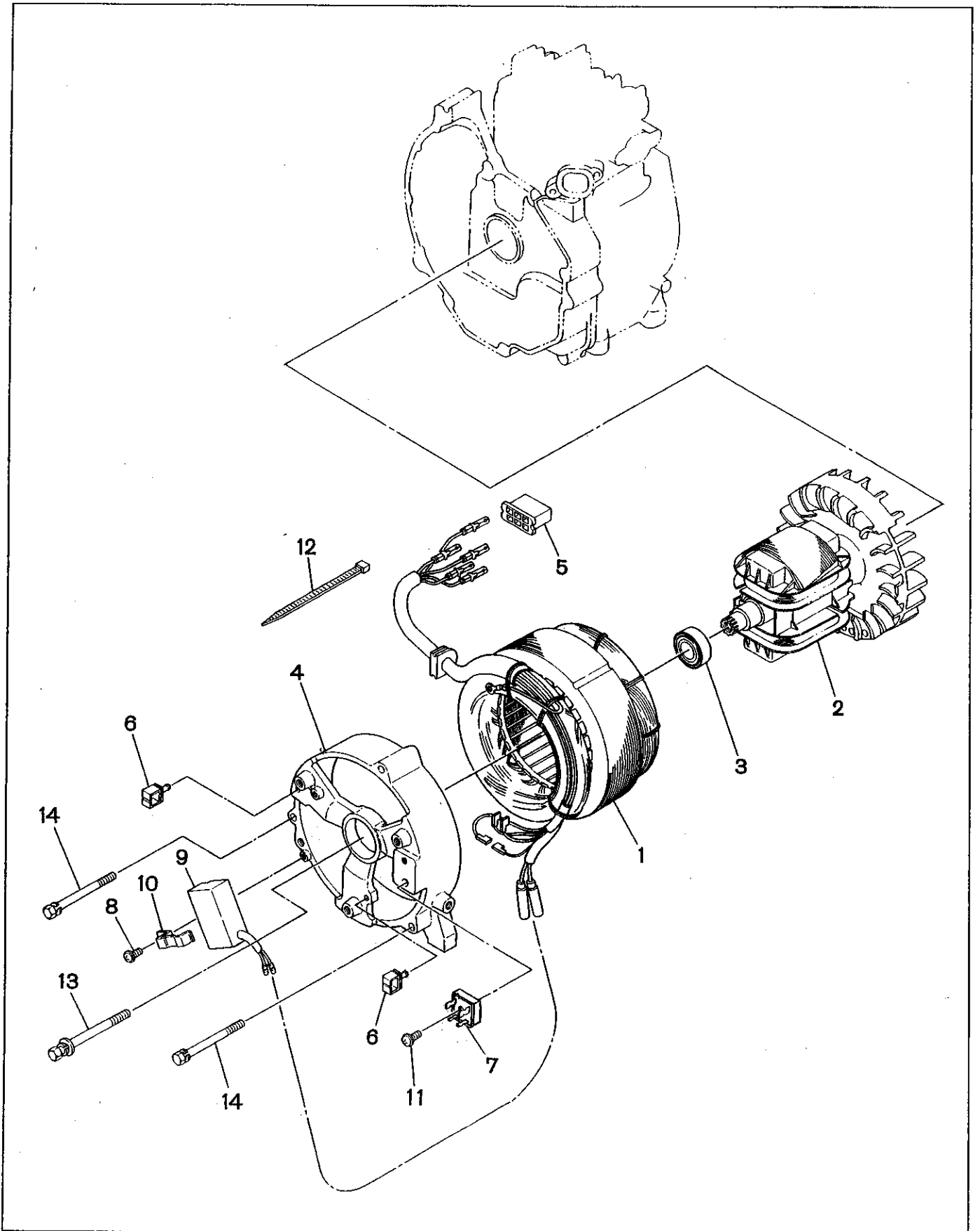
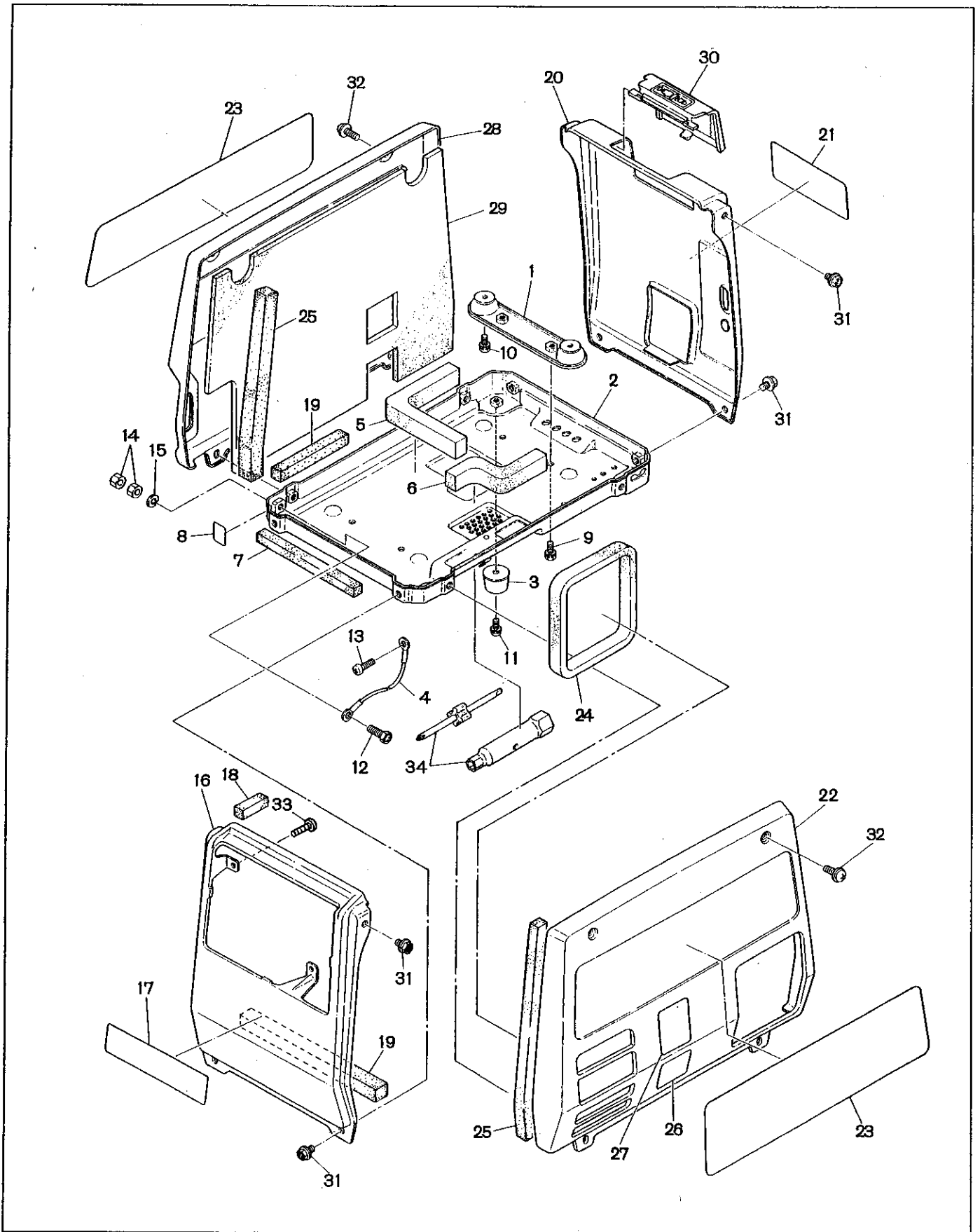

FIG. 1 GENERATOR



RG006037060

FIG. 2 COVER



RG006037060

2. COVER

Ref.	Parts Number	Parts Name	Q'ty	Remarks	InterchangeP/N	Memo
1	358-30101-11	MOUNT (A) CP	2			
2	358-30601-51	BASE PLATE CP	1			
3	358-30201-01	MOUNT (B) CP	4			
4	358-35102-01	EARTH WIRE CP	1			
5	383-36101-03	SEAL 1 (BASE)	1			
6	383-36102-03	SEAL 2 (BASE)	1			
7	383-36103-03	SEAL 3 (BASE)	1			
8	073-20026-51	LABEL,EARTH	1			
9	001-16051-00	BOLT & WASHER AY	4			
10	001-14061-20	BOLT & WASHER AY	4			
11	004-35051-00	SCREW & WASHER AY	4			
12	010-00602-91	BOLT	1			
13	014-00601-21	SCREW	1			
14	002-29060-01	NUT	2			
15	003-20060-00	SPRING WASHER	1			
16	358-53002-31	FRONT COVER CP	1	BLACK		
17	383-91704-13	LABEL,TRADE MARK	1			
18	383-55502-13	SEAL 1,COVER	2			
19	383-55503-03	SEAL 2,COVER	2			
20	383-50701-01	REAR COVER CP	1	BLACK		
21	383-91927-23	LABEL,SPEC	1			
22	383-51116-11	SIDE COVER (R) CP	1	CANARY YELLOW		
23	383-91703-13	LABEL,TRADE MARK	2			
24	383-55501-03	SEAL(EXHAUST)	1			
25	383-55504-03	SEAL 3,COVER	2			
26	073-20051-90	LABEL	1			
27	073-20045-00	LABEL,HOT & GAS	1			
28	358-53402-41	SIDE COVER (L) CP	1	Incl.29 C.YELLOW		
29	383-55302-13	SPONGE (L)	1			
30	383-55101-03	PLUG COVER	1			
31	011-00600-60	FLANGE BOLT	8			
32	358-55201-03	FLANGE SCREW	8			
33	383-40769-08	TAPPING SCREW	3			
34	358-90301-10	ACCESSORY TOOL KIT	1			

RG006037060

FIG. 3 CONTROL PANEL

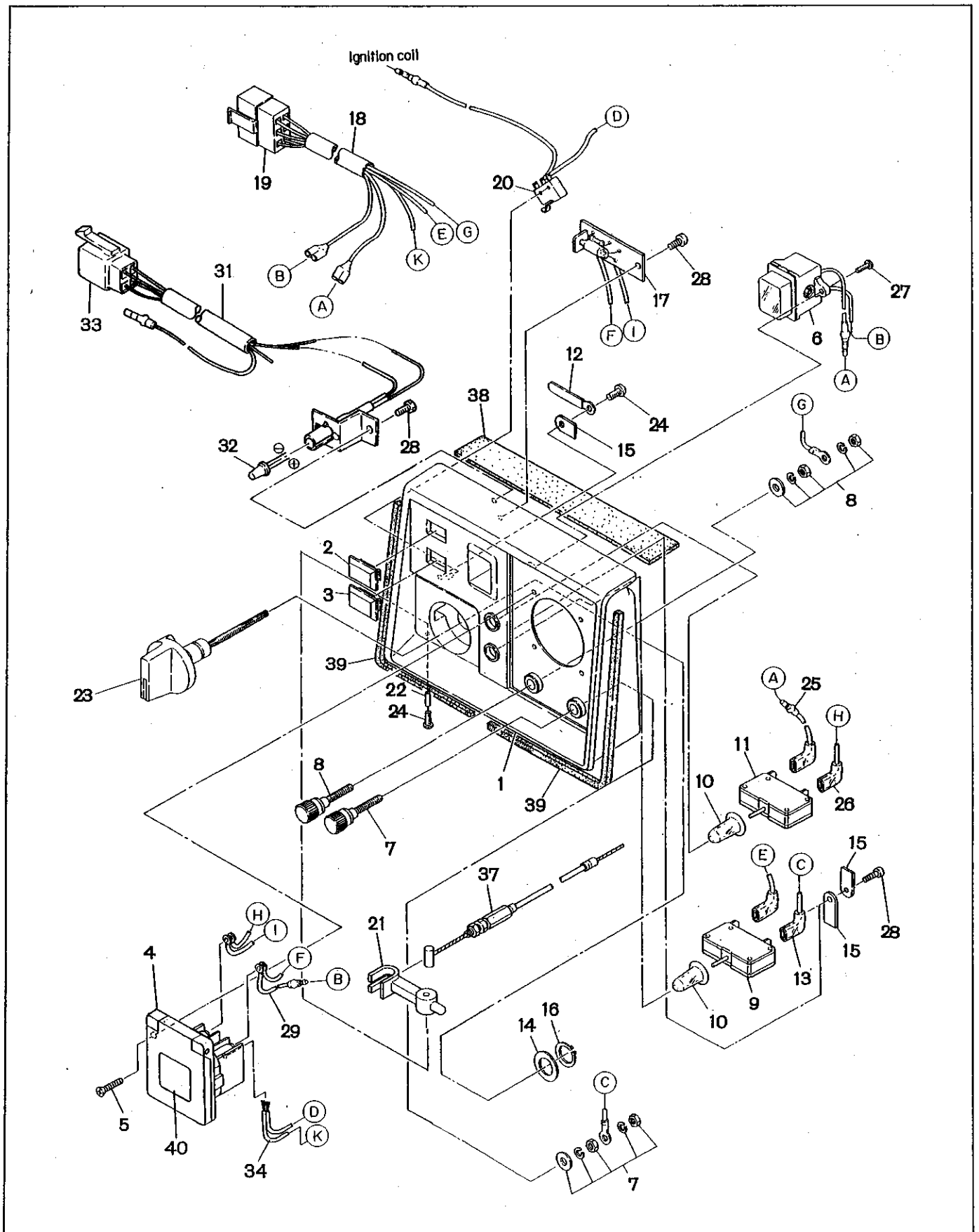

3. CONTROL PANEL

Ref.	Parts Number	Parts Name	Q'ty	Remarks	InterchangeP/N	Memo
1	383-40759-11	CONTROL PANEL CP	1	Incl.2~34		
2	358-41133-08	CAP	1	CLEAR		
3	358-40651-08	CAP	1	GREEN		
4	358-40621-08	AC RECEPTACLE	1			
5	383-40774-08	TAPPING SCREW	4			
6	383-40680-08	VOLT METER	1			
7	383-40686-08	TERMINAL BOLT	1	RED		
8	383-40687-08	TERMINAL BOLT	1	BLACK		
9	383-40633-08	CIRCUIT BREAKER	1	10A		
10	383-40750-08	CAP	2	CLEAR		
11	383-40638-08	CIRCUIT BREAKER	1	2A		
12	358-41150-08	CLAMP	1			
13	383-40729-08	WIRE 40 CP	1	RED		
14	358-40687-08	WASHER	1			
15	383-40757-08	CLAMP	3			
16	358-40653-08	CLIP	1			
17	383-40696-08	LAMP	1			
18	383-40666-08	WIRE HARNESS	1	Incl.19		
19	358-21021-08	CONNECTOR	1	6P		
20	358-40643-08	MICRO SWITCH	1			
21	383-40752-08	LEVER	1			
22	358-40658-08	PIN	1			
23	358-40644-08	KNOB	1			
24	358-40669-08	TAPPING SCREW	2			
25	383-40731-08	WIRE 42 CP	1	BROWN		
26	383-40732-08	WIRE 43 CP	1	BROWN		
27	358-40661-08	TAPPING SCREW	2			
28	358-40660-08	TAPPING SCREW	3			
29	383-40733-08	WIRE 44 CP	1	WHITE		
31	358-40646-08	WIRE HARNESS CP	1	Incl.32,33		
32	358-41131-08	LED	1			
33	358-41132-08	CONNECTOR	1	4P		
34	383-40730-08	WIRE 41 CP	1	GREEN/YELLOW		
37	383-45101-01	CHOKE WIRE CP	1			

RG006037060

FIG. 3 CONTROL PANEL

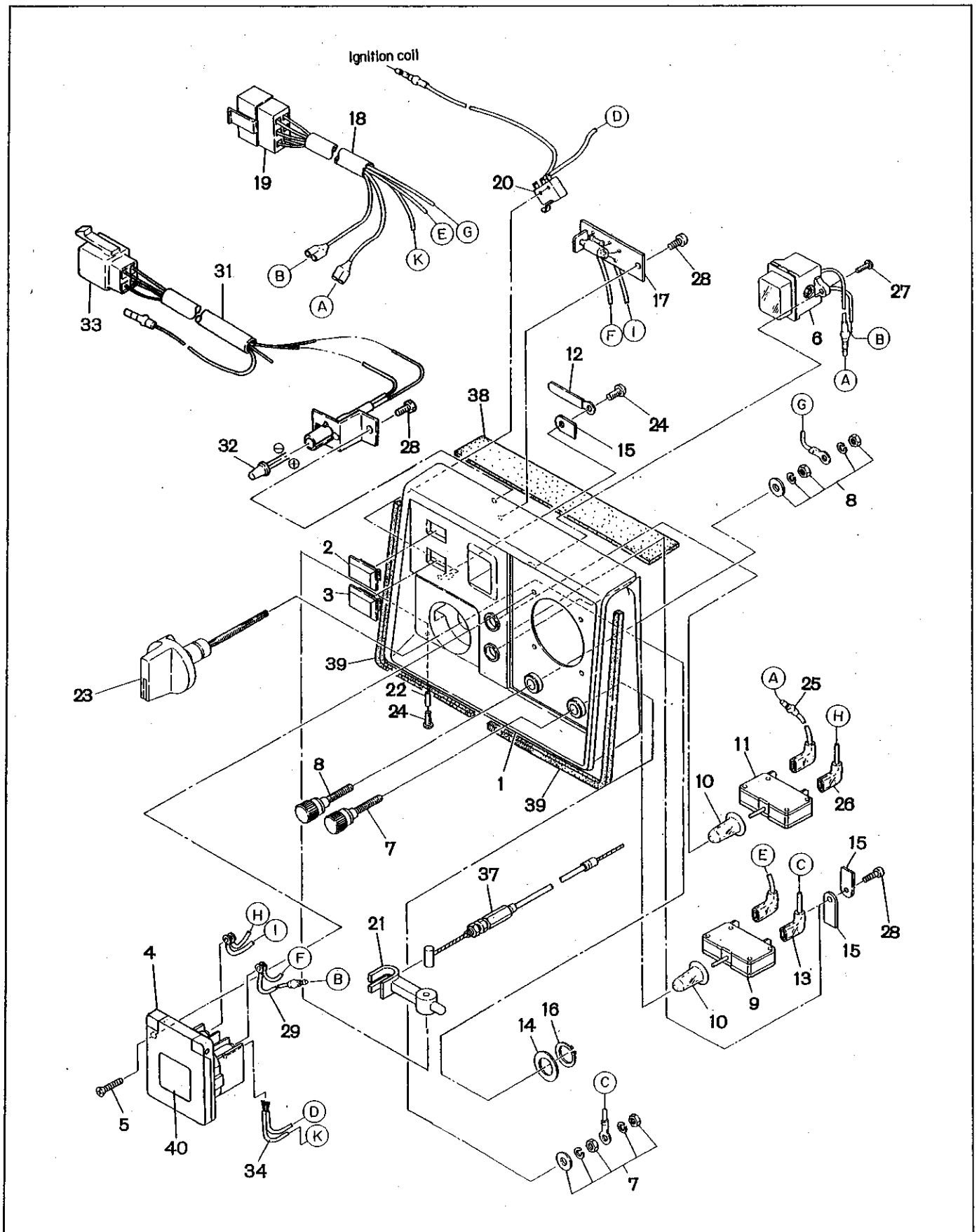

FIG. 4 FUEL TANK

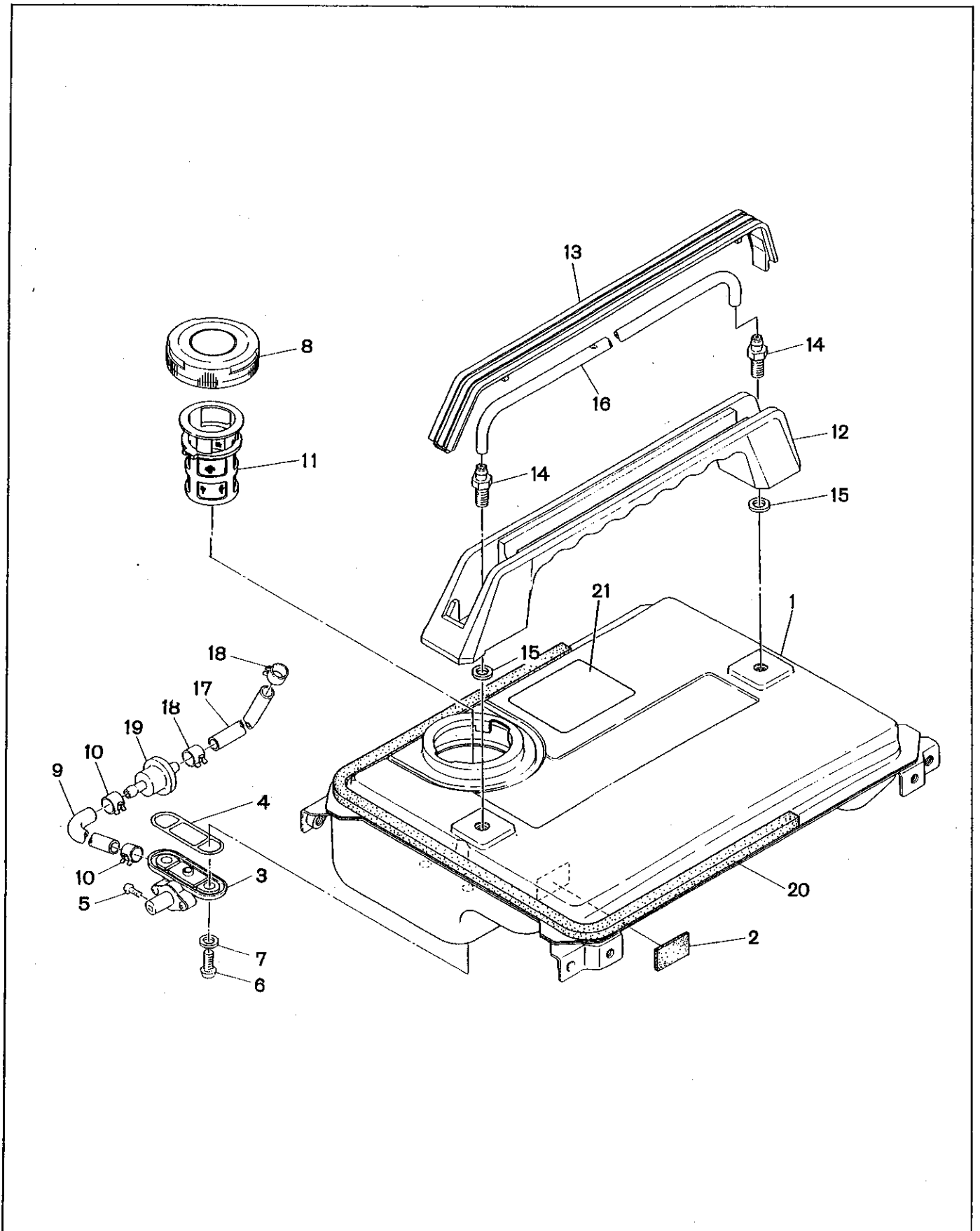
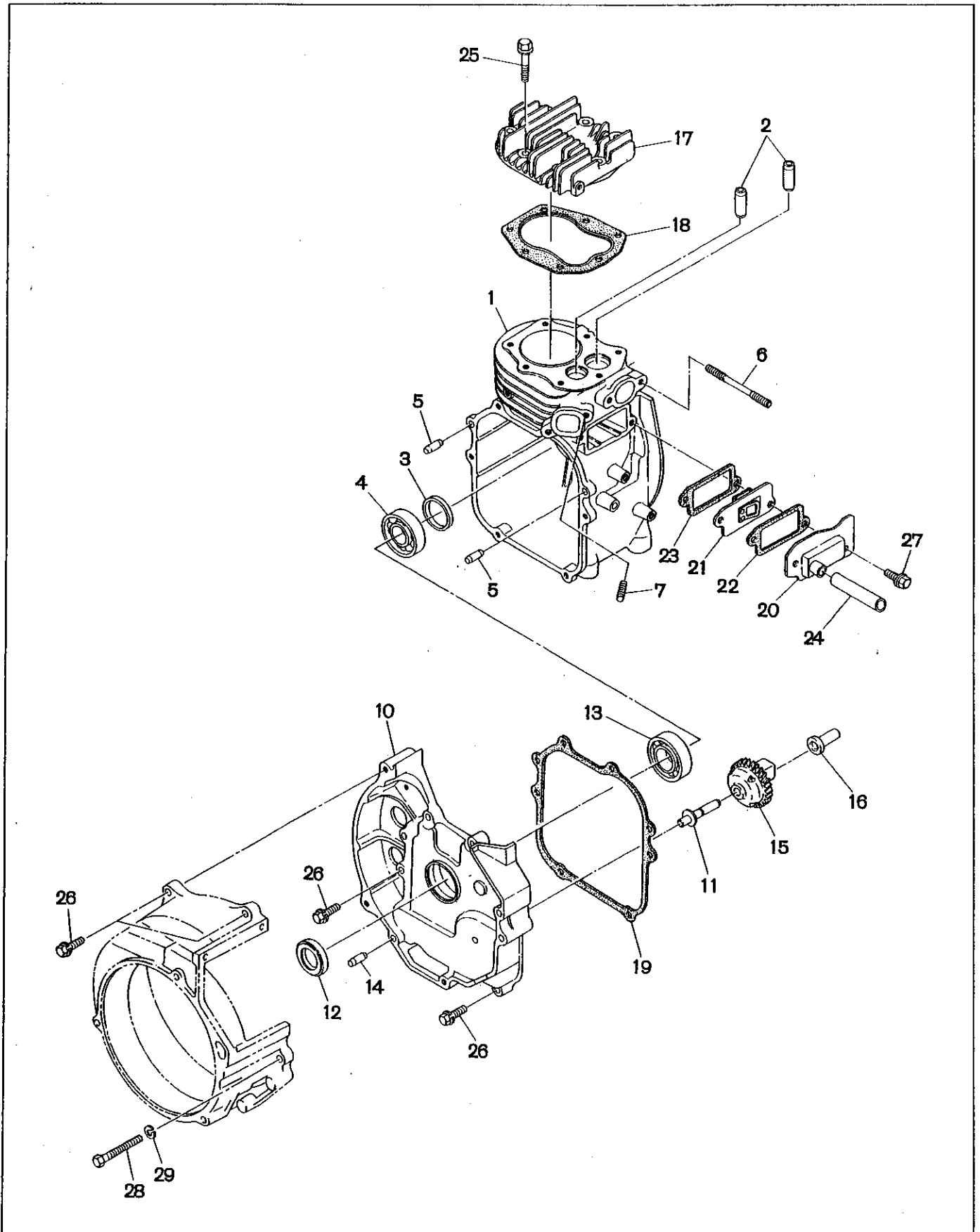

FIG. 5 CRANKCASE



RG006037060

5. CRANKCASE

Ref.	Parts Number	Parts Name	Q'ty	Remarks	InterchangeP/N	Memo
1	230-10202-31	CRANK CASE CP	1	Incl.2~7		
2	230-14202-03	VALVE GUIDE	2			
3	230-17102-03	PLUG (RUBBER)	1			
4	060-02001-30	BALL BEARING	1			
5	031-00600-20	DOWEL PIN	2			
6	010-50601-60	STUD	2			
7	010-50601-70	STUD	2			
10	230-11201-31	MAIN BEARING COV CP	1	Incl.11~14		
12	044-02000-70	OIL SEAL	1			
13	060-02001-30	BALL BEARING	1			
14	031-00600-20	DOWEL PIN	2			
15	230-45003-01	GOVERNOR GEAR CP	1			
16	205-41901-03	GOVERNOR SLEEVE	1			
17	230-13101-03	CYLINDER HEAD	1			
18	230-15001-11	GASKET CP(HEAD)	1			
19	230-16001-03	GASKET(BEARING COV)	1			
20	230-14301-01	TAPPET COVER CP	1			
21	230-14401-01	BREATHER PLATE CP	1			
22	230-16006-13	GASKET(TAPPET COV)	1			
23	230-16007-03	GASKET (BREATHER)	1			
24	085-10802-41	RUBBER PIPE	1	8DX11DX48L	085-10800-00	
25	011-00600-90	FLANGE BOLT	7			
26	001-13062-50	BOLT & WASHER AY	8			
27	011-00600-20	FLANGE BOLT	2			
28	001-66065-50	BLOT	1			
29	003-20060-00	SPRING WASHER	1			
*	230-99002-17	GASKET SET	1			

RG006037060

FIG. 6 CRANKSHAFT and PISTON

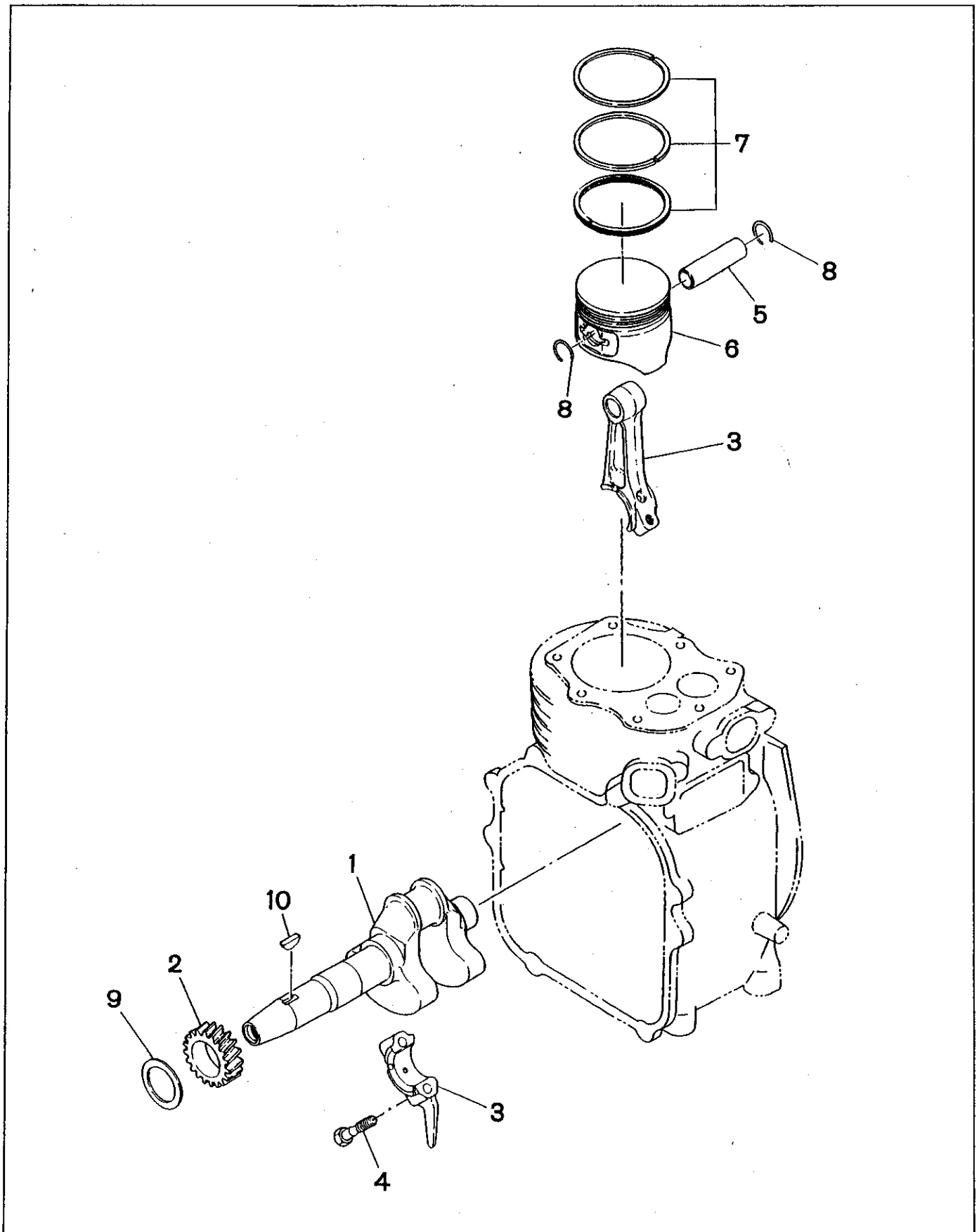

RG006037060

FIG. 7 INTAKE and EXHAUST

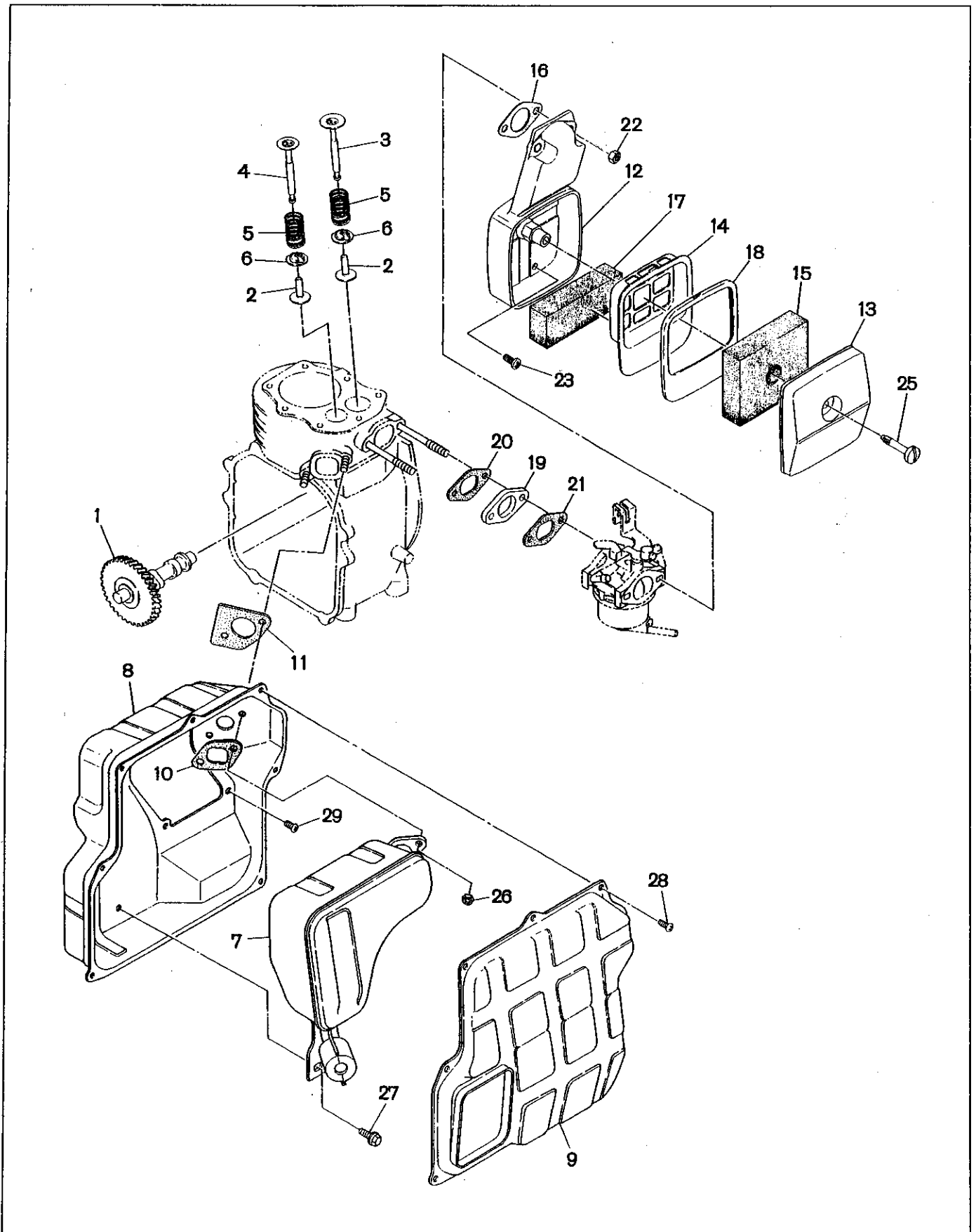

RG006037060

7. INTAKE, EXHAUST

Ref.	Parts Number	Parts Name	Q'ty	Remarks	InterchangeP/N	Memo
1	230-31801-03	CAMSHAFT	1			
2	230-33301-03	TAPPET	2			
3	230-33401-03	INTAKE VALVE	1			
4	230-33501-13	EXHAUST VALVE	1			
5	230-33601-03	VALVE SPRING	2			
6	230-33701-03	SPRING RETAINER	2			
7	230-30502-11	MUFFLER CP	1			
8	230-34213-03	MUFFLER COVER 1	1		230-34220-01	
9	230-34214-03	MUFFLER COVER 2	1		230-34222-01	
10	230-35204-01	GASKET CP(EXHAUST)	1			
11	230-35202-11	GASKET CP (MF-COV)	1			
12	230-35502-22	CLEANER CASE UN	1			
13	230-35501-33	CLEANER COVER	1			
14	230-36101-23	ELEMENT RETAINER	1			
15	230-36102-03	CLEANER ELEMENT	1			
16	230-36003-03	GASKET,AIR CLEANER	1			
17	230-36103-13	CLEANER ELEMENT 2	1			
18	230-36301-03	GROMMET,AIR CLEANER	1			
19	230-32901-13	INSULATOR	1			
20	230-35901-13	GASKET (INSULATOR)	1			
21	230-35902-03	GASKET 2 (INSULATOR)	1			
22	002-38060-00	FLANGE NUT	2			
23	004-31050-80	SCREW,PANHEAD	1			
25	230-36201-03	BOLT,CLEANER COVER	1			
26	002-19060-00	NUT	2			
27	011-00600-20	FLANGE BOLT	1			
28	015-20500-10	TAPPING SCREW	7			
29	004-31050-80	SCREW,PANHEAD	4			

RG006037060

FIG. 8 GOVERNOR, OPERATION

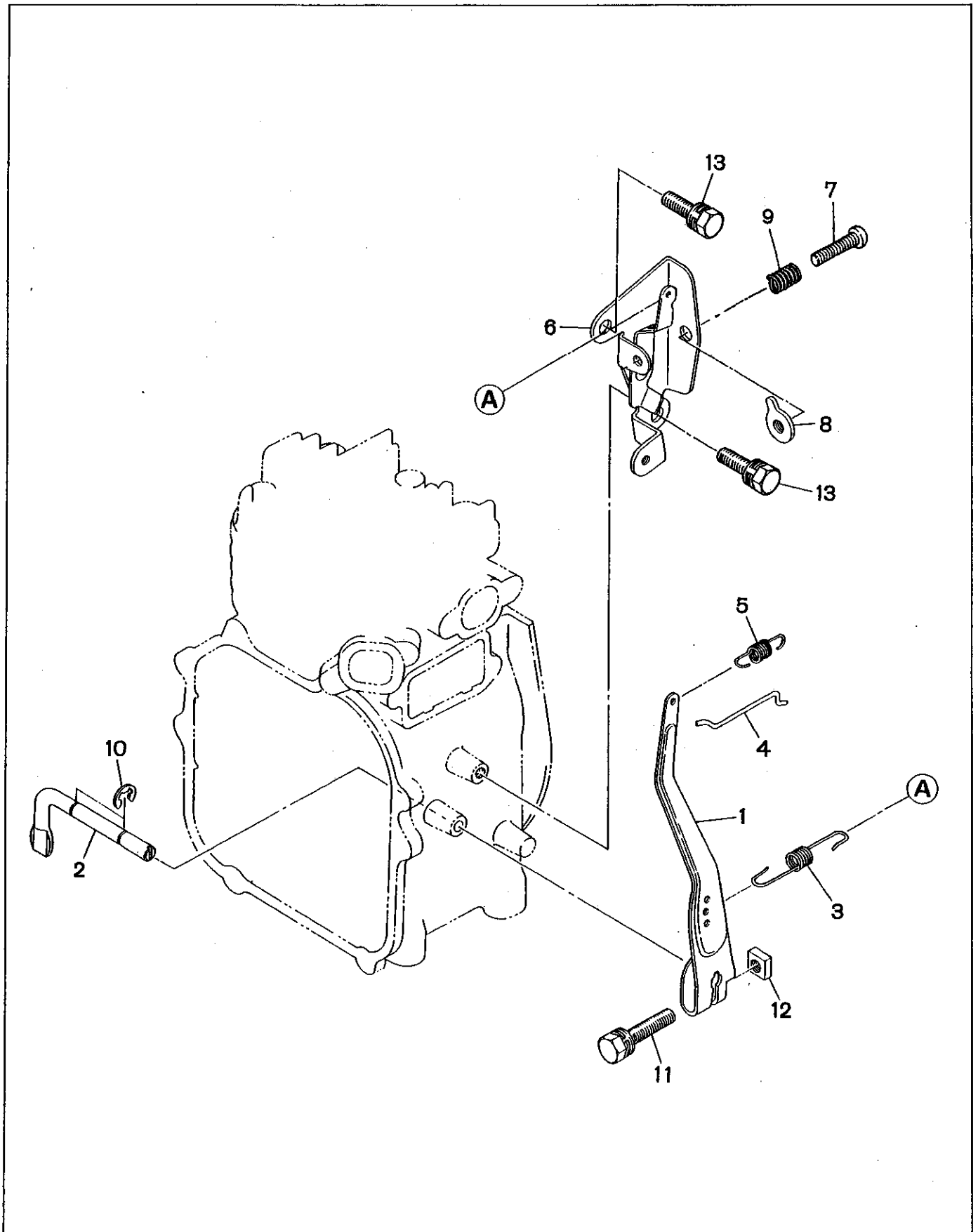

RG006037060

FIG. 9 COOLING and STARTING

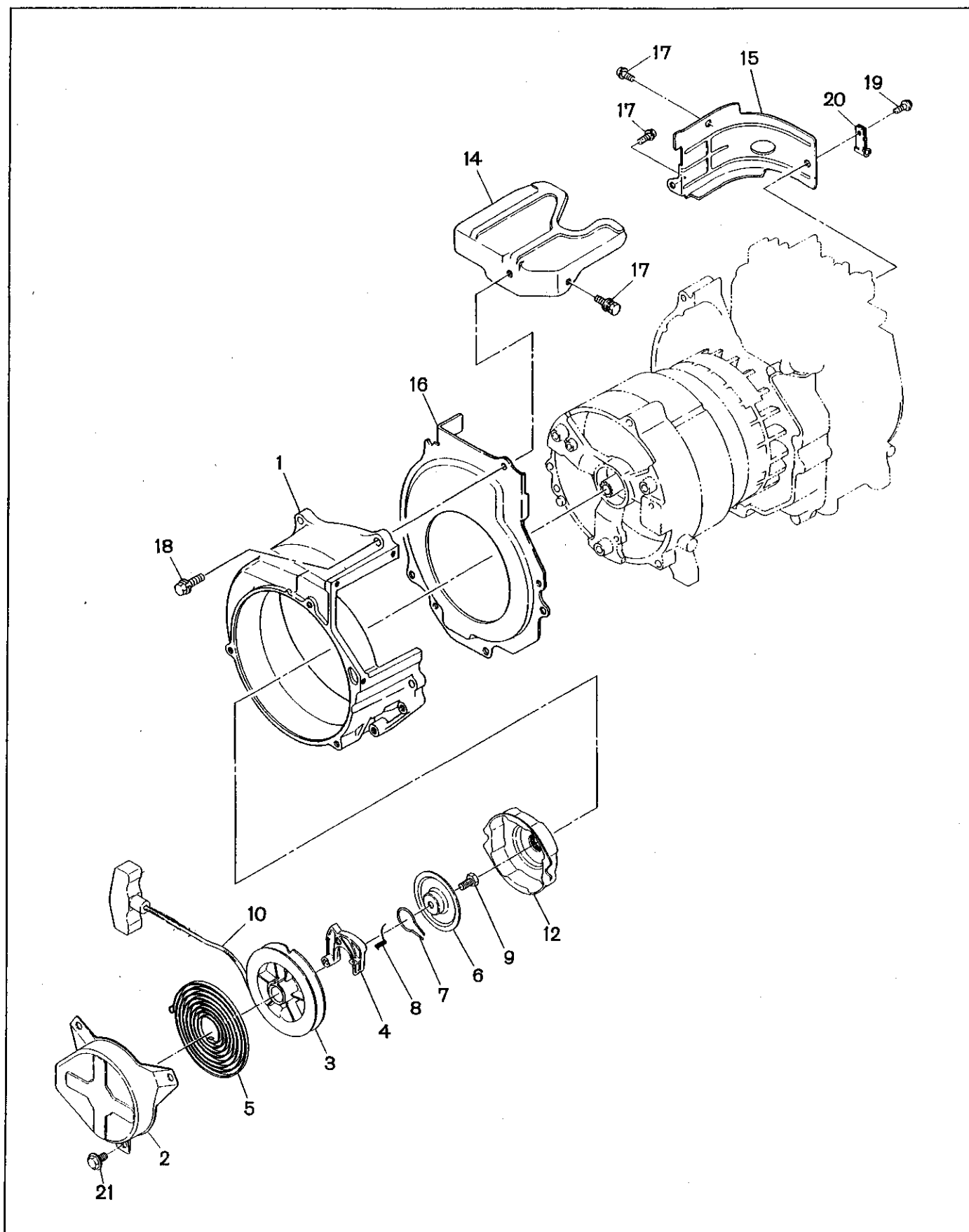

RG006037060

FIG. 10 FUEL LUBRICANT

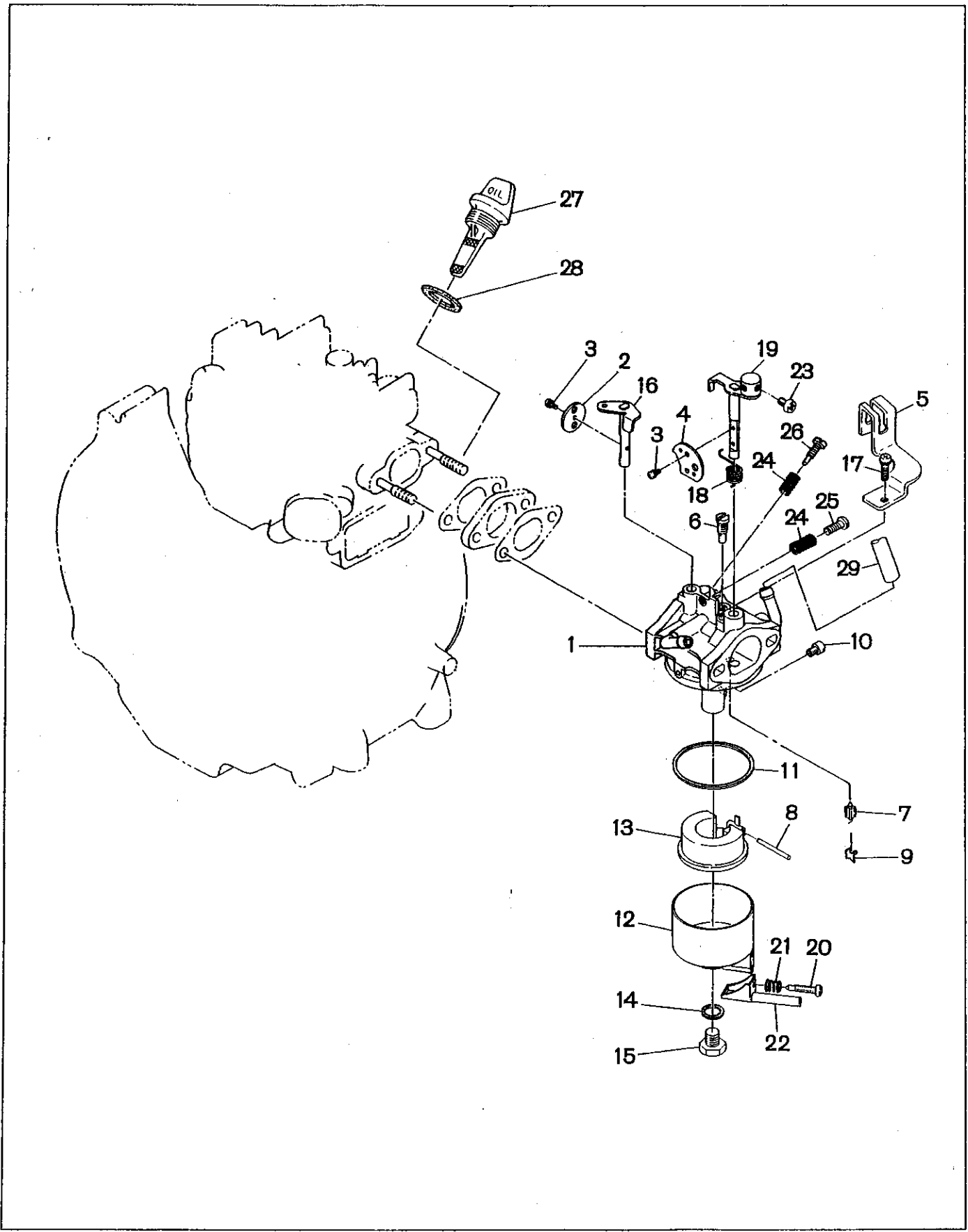

10. FUEL LUBRICANT

Ref.	Parts Number	Parts Name	Q'ty	Remarks	InterchangeP/N	Memo
1	230-62402-30	CARBURETOR AY	1	Incl.2~26		
2	230-62537-08	THROTTLE VALVE	1	#130		
3	237-62451-08	SCREW	3			
4	230-62527-08	CHOKE VALVE	1			
5	230-62572-08	BRACKET	1			
6	128-62420-08	PILOT JET	1	#37.5		
7	226-62500-08	NEEDLE VALVE AY	1			
8	214-62515-08	PIN	1			
9	226-62701-08	CLIP	1			
10	230-62400-08	MAIN JET	1	#55		
11	230-62540-08	PACKING	1			
12	230-62554-08	FLOAT CHAMBER BODY	1			
13	230-62506-08	FLOAT AY	1			
14	209-62345-08	INSERT WASHER	1			
15	230-62457-08	BOLT	1			
16	230-62530-08	SHAFT ASSY,THROTTLE	1			
17	230-62455-08	SCREW	1			
18	230-62447-08	SPRING	1			
19	230-62521-18	SHAFT AY,CHOKE	1			
20	224-62450-08	SCREW	1			
21	230-62446-08	SPRING	1			
22	230-62561-08	CAP	1			
23	209-62354-08	CROSS SCREW	1			
24	206-62446-08	SPRING	2			
25	209-62352-08	SCREW	1			
26	209-62305-08	PILOT SCREW	1			
27	230-63601-01	OIL GAUGE CP	1	Incl.28	230-63601-11	
28	021-31600-20	GASKET	1			
29	230-68507-03	PIPE,AIR VENT	1	5DX8DX320L RUBBER		

RG006037060

FIG. 11 ELECTRIC DEVICE

