

Model **RGX4800**

For RAI

PARTS CATALOG

Spec. No. RLE48044022
(E/G Spec. No. EX270D20302)

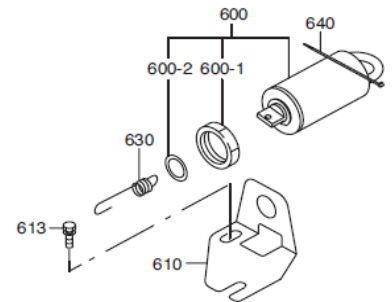
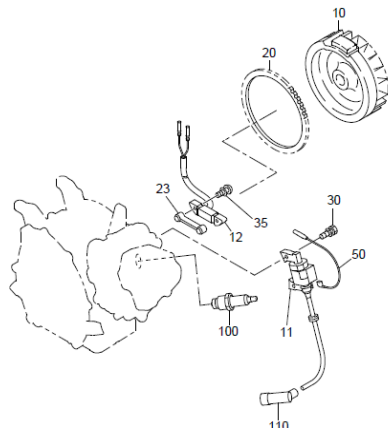
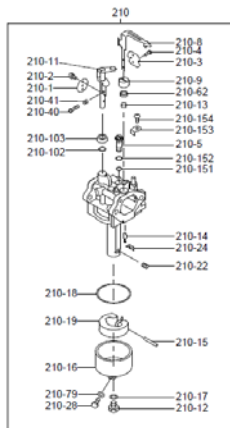
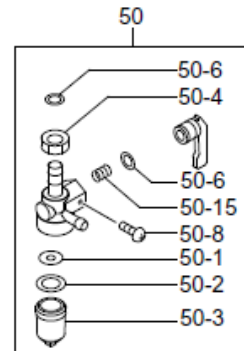
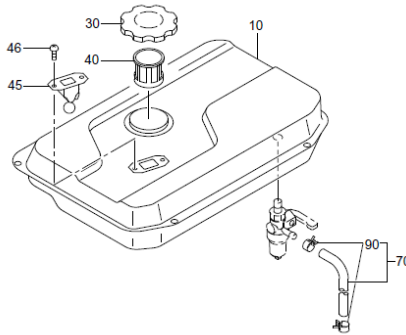
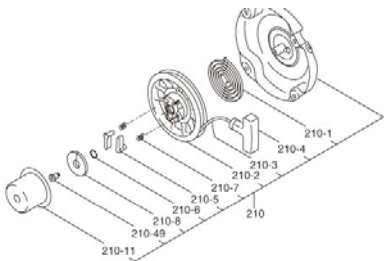
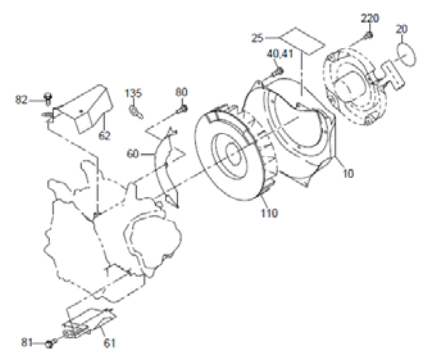
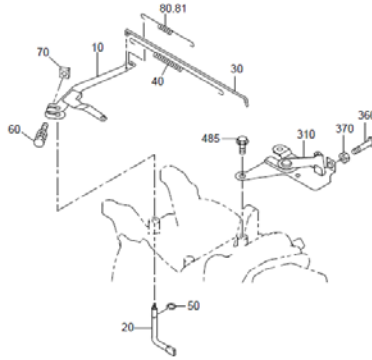
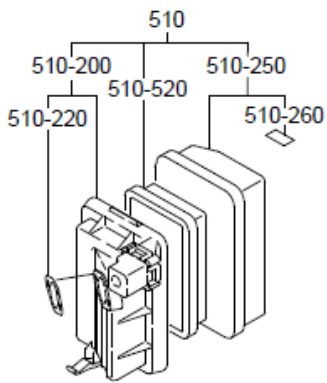
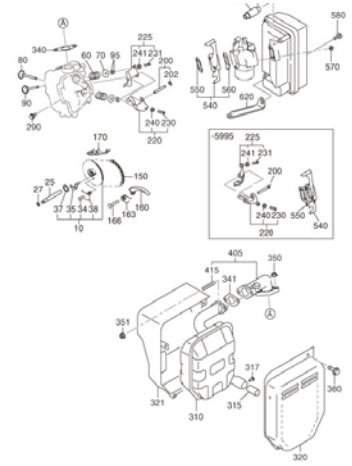
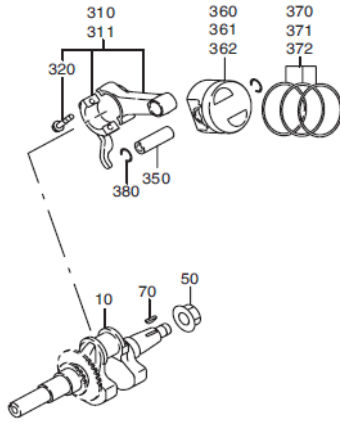
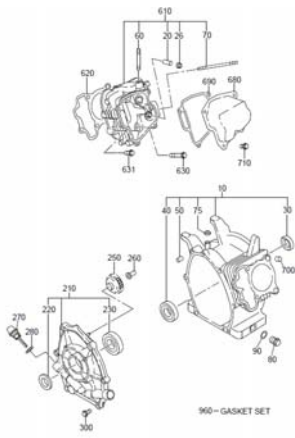

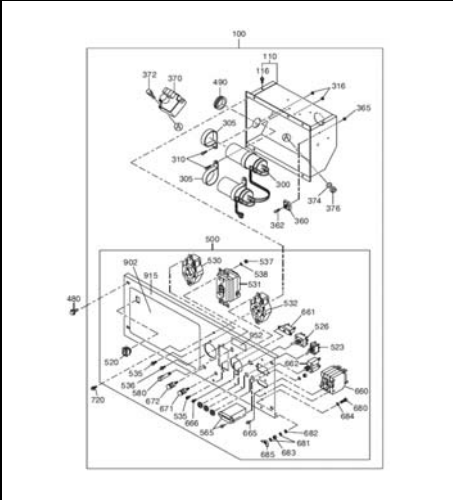
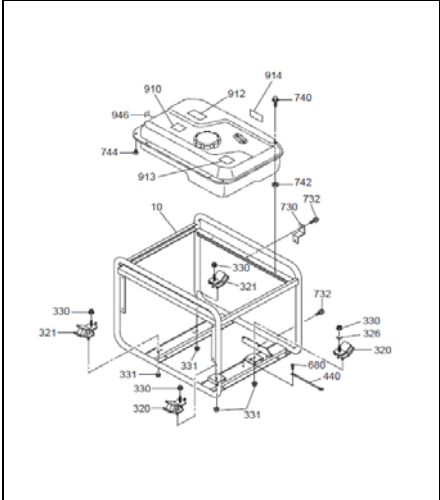
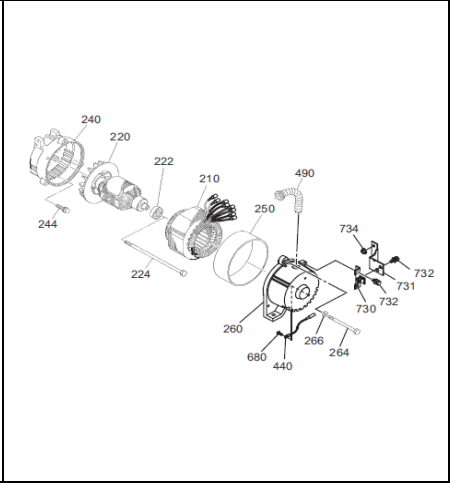
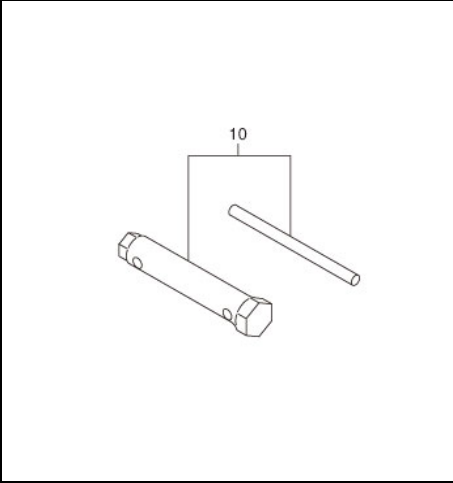
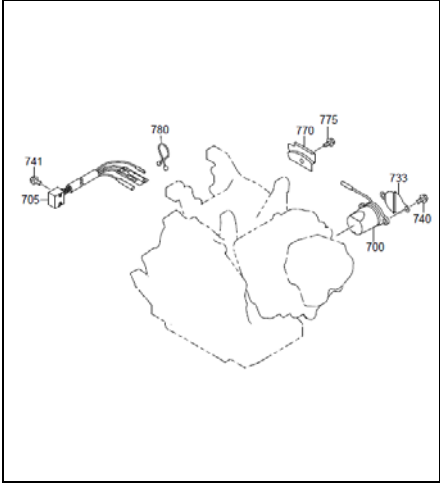
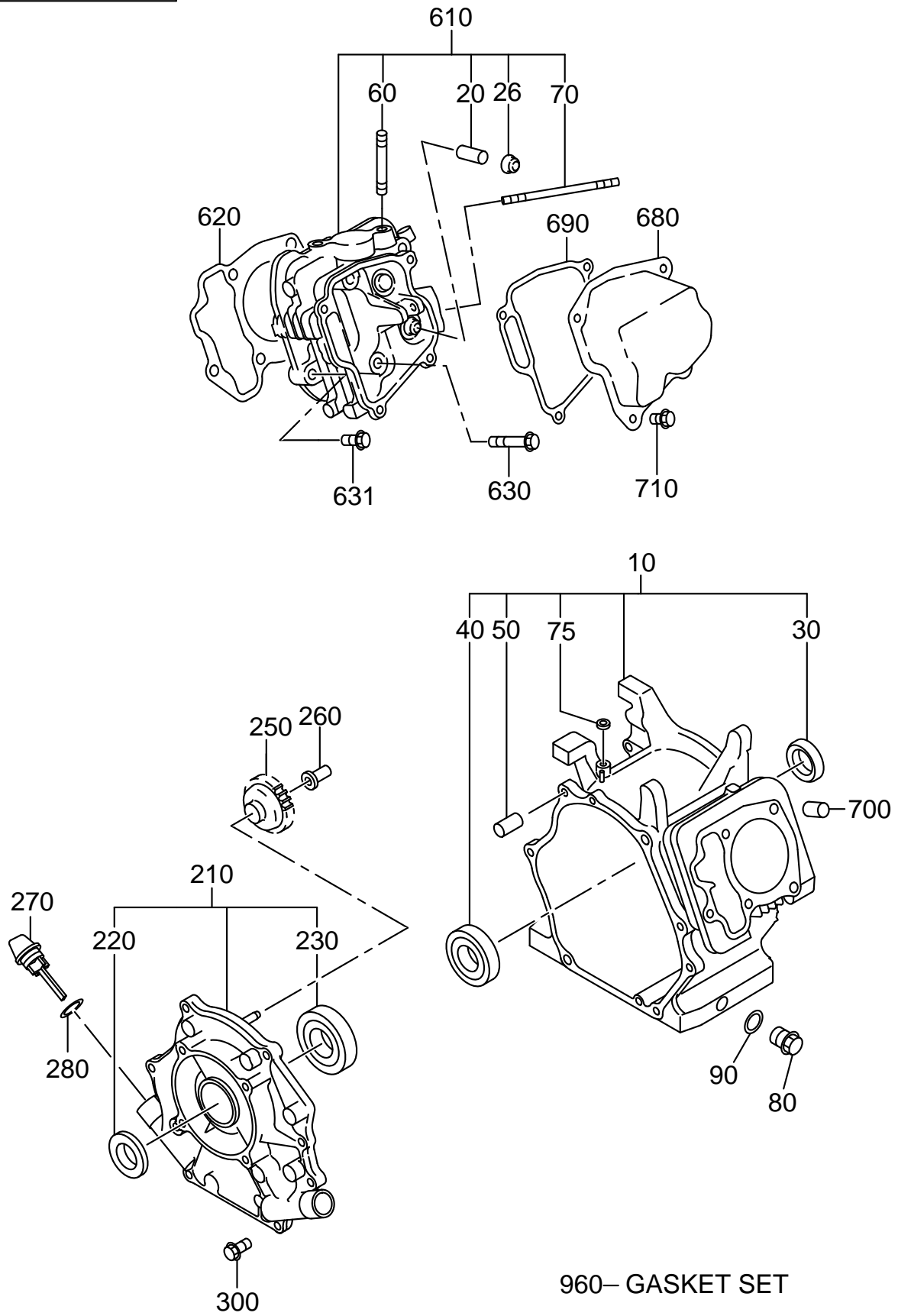

FIG. 100



960- GASKET SET

REF.	PART NUMBER	PART NAME	QTY	R E M A R K S	CODE NO.	INTERCHANGE P/NC
10	279-10102-91	CRANK CASE CP	1	W/OIL SENSOR	-	
20	237-14202-03	VALVE GUIDE	2	5.5DX9.5DX27L	-	
26	277-16010-01	STEM SEAL	1	5.5DX9.5DX15DX7.8B	-	
30	044-03001-60	OIL SEAL	1	30DX45DX7B	-	
40	060-03003-41	BALL BEARING	1	30DX62DX16B	-	
50	277-15011-03	PIPE KNOCK	2	10.3DX8.5DX14L	-	
60	010-50802-90	STUD	2	M8X1.25X30L	-	
70	010-50604-10	STUD	2	M6X1.0X107L	-	
75	044-00600-20	OIL SEAL	1	6DX10DX2.5B	-	
80	040-11400-30	PLUG	2	M14X1.5X20DX12L	-	
90	021-11400-20	GASKET	2	14.1DX19DX2.3T	-	
210	279-11101-21	MAIN BEARING COVER C	1	FLANGE 4-M8X1.25	-	
220	044-03001-60	OIL SEAL	1	30DX45DX7B	-	
230	060-03003-70	BALL BEARING	1	30DX62DX16B	-	
250	277-45004-J1	GOVERNOR GEAR CP	1	53DX29.1T N=33	-	
260	277-41901-03	GOVERNOR SLEEVE	1	6DX7.6DX16DX26L	-	
270	279-63601-23	OIL GAUGE	2	M22X1.5 L=67.5+18	-	
280	021-32000-50	GASKET	2	20DX27DX1.5T RUBBER	-	
300	001-04083-50	FLANGE BOLT	7	M8X1.25X16DX35L	-	
610	279-13002-31	CYLINDER HEAD CP	1		-	
620	279-15001-33	GASKET (HEAD)	1	T=0.2	-	
630	011-00802-40	FLANGE BOLT	4	M8X1.25X16DX68L	-	
631	011-00803-10	FLANGE BOLT	1	M8X1.25X16DX33L	-	
680	277-15503-01	ROCKER COVER CP	1		-	
690	277-16001-13	GASKET(ROCKER COVER)	1	T=0.5	-	
700	277-15011-03	PIPE KNOCK	2	10.3DX8.5DX14L	-	
710	011-00600-20	FLANGE BOLT	4	M6X1.0X14DX12L	-	
960	279-99001-27	GASKET SET	1		-	

FIG. 200

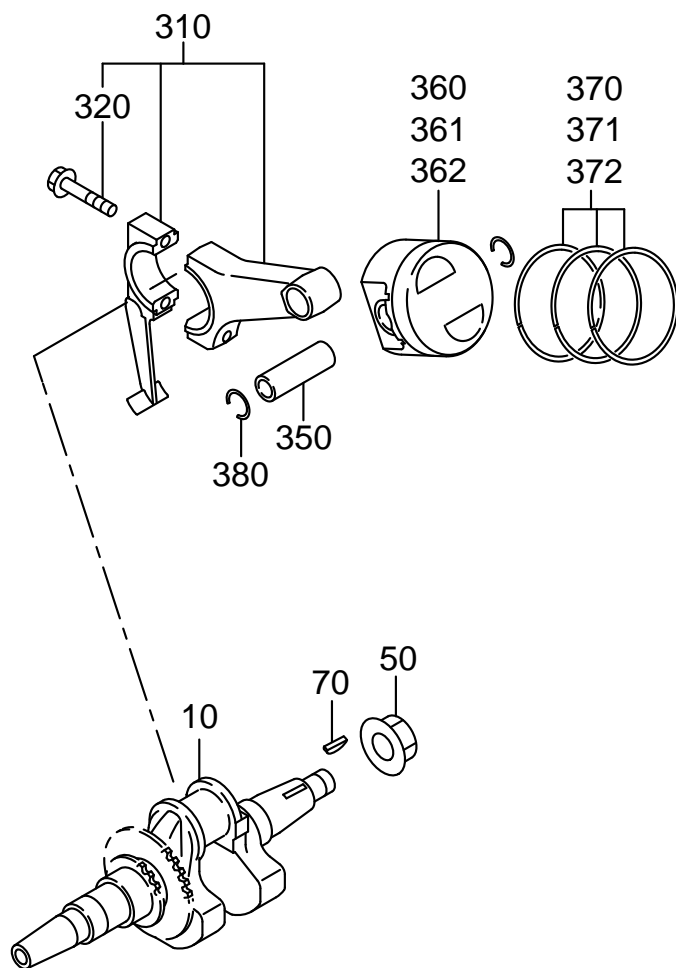

REF.	PART NUMBER	PART NAME	QTY	R E M A R K S	CODE NO.	NTERCHANGE P/NC
10	279-20701-41	CRANKSHAFT CP	1	L=280 26DX1/10 TAPER	-	
50	018-01800-10	FLANGE NUT	1	M18X1.5X31DX14H	-	
70	032-30300-10	WOODRUFF KEY	1	3BX6HX16D	-	
310	279-22501-30	CONNECTING ROD AY	1	104.5CDX26B 34.5D-18	-	
320	279-23001-03	CONNECTING ROD BOLT	2	M7X1.0X13.8DX40L	-	
350	279-23301-13	PISTON PIN	1	18DX13DX53L	-	
360	279-23401-H3	PISTON	1	STD (75DX43H)	-	
361	279-23403-H3	PISTON	1	0.25 O.S.(75DX43H)	-	
362	279-23404-H3	PISTON	1	0.50 O.S.(75DX43H)	-	
370	279-23511-17	PISTON RING SET	1	STD (75D) OIL EXPAND	-	
371	279-23512-17	PISTON RING SET	1	0.25 O.S. OIL EXPAND	-	
372	279-23513-17	PISTON RING SET	1	0.50 O.S. OIL EXPAND	-	
380	056-51800-10	CLIP	2	18.9DX1.6D	-	

FIG. 301

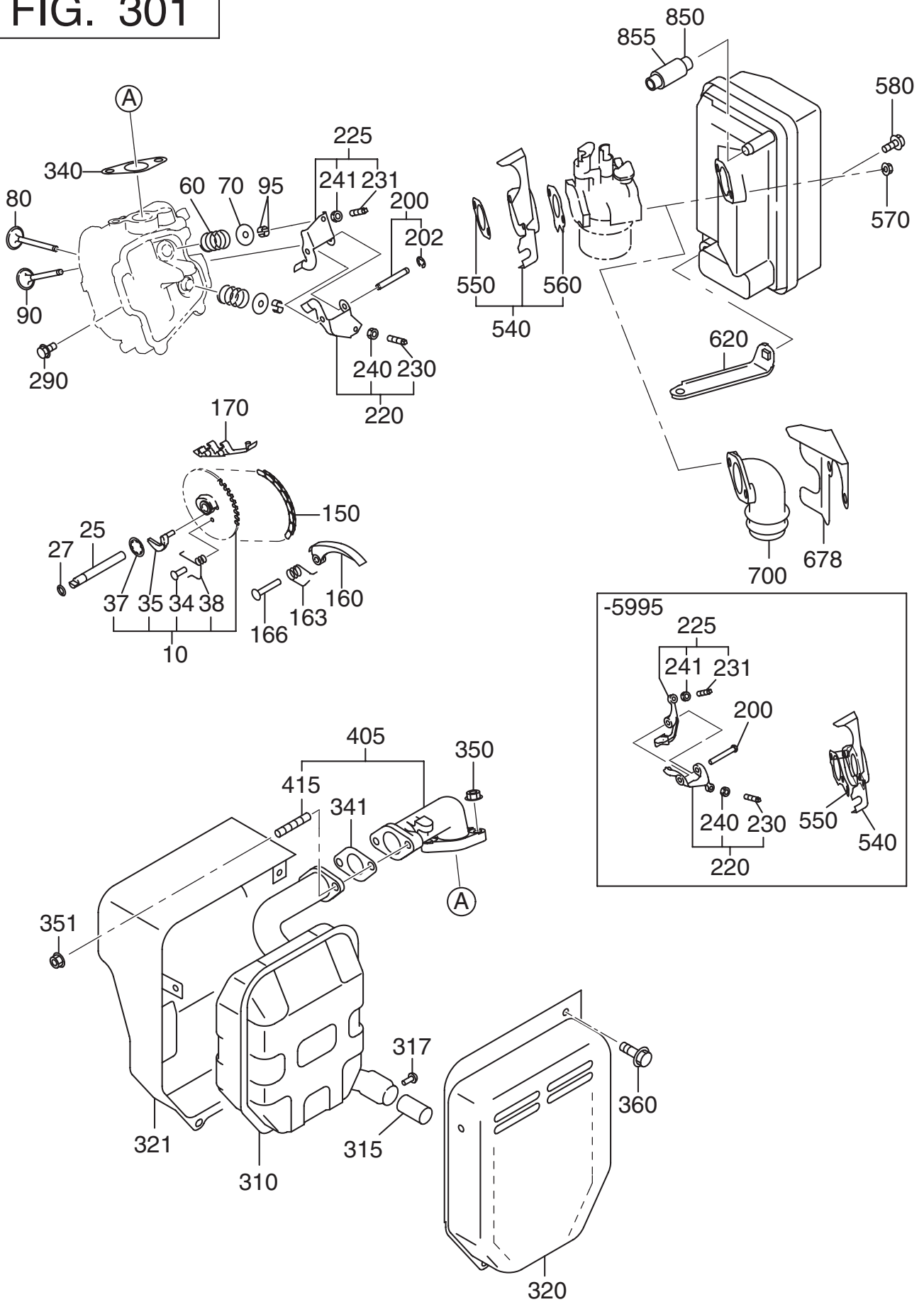

REF.	PART NUMBER	PART NAME	QTY	R E M A R K S	CODE NO.	INTERCHANGE P/NC
10	279-31602-11	CAM SHAFT CP	1	93DX2.9B N=44	-	
25	277-35101-03	PIN(CAM SHAFT)	1	9DX78.5L	-	
27	024-00600-10	O RING	1	5.8DX9.6D	-	
34	277-38601-03	PIN(SPRING)	1	4DX8DX9L	-	
35	279-36401-03	RELEASE LEVER	1		-	
37	277-36501-03	CLIP	1	13.8DX20.3DX0.4T	-	
38	279-38701-13	RETURN SPRING	1	5.3DX0.6DX5.5L N=5.7	-	
60	279-33601-03	VALVE SPRING	2	19.2DX2.3DX27.4L	-	
70	269-33701-03	SPRING RETAINER	2		-	
80	279-33401-H3	INTAKE VALVE	1	28.5DX5.5DX67.8L	-	
90	279-33501-H3	EXHAUST VALVE	1	26.5DX5.5DX67.8L	-	
95	132-10KA0-31	COLLET-VALVE	4		-	
150	279-35601-11	TIMING CHAIN CP	1	100 LINK	-	
160	277-36911-03	TENTIONER	1		-	
163	277-37101-03	SPRING(TENTIONER)	1	10DX1.8DX14L N=4.5	-	
166	277-36902-03	PIN(TENTIONER)	1	6DX13DX34L	-	
170	277-36913-13	CHAIN GUIDE	1		-	
200	277-35002-01	PIN(ROCKER) CP	1	6DX46L	-	
202	003-13050-00	CLIP	1	5DX11DX0.6T	-	
220	277-36201-00	ROCKER ARM(IN) AY	1		-	
225	277-36202-00	ROCKER ARM(EX) AY	1		-	
230	014-90500-20	ADJUST SCREW	1	M5X0.5X23L	-	
231	014-90500-20	ADJUST SCREW	1	M5X0.5X23L	-	
240	017-00500-30	NUT	1	M5X0.5X4.1H	-	
241	017-00500-30	NUT	1	M5X0.5X4.1H	-	
290	011-00600-20	FLANGE BOLT	1	M6X1.0X14DX12L	-	
310	279-30202-01	MUFFLER CP	1		-	
315	279-37602-01	SPARK ARRESTER CP	1		-	
317	015-00400-60	TAPPING SCREW	1	M4X6L	-	
320	279-34501-11	MUFFLER COVER(1) CP	1		-	
321	279-34601-11	MUFFLER COVER(2) CP	1		-	
340	277-35201-13	GASKET(MUFFLER)	1	T=0.2 26D 9DX58P	-	
341	277-35201-01	GASKET CP(EXHAUST)	1	T=1.6 28D 8.5DX52P	-	
350	980-20082-80	FLANGE NUT	2	M8X1.25X17DX7.5H	-	
351	980-20082-80	FLANGE NUT	2	M8X1.25X17DX7.5H	-	
360	011-00600-20	FLANGE BOLT	3	M6X1.0X14DX12L	-	
405	277-34001-01	EXHAUST PIPE CP	1		-	
415	010-50802-90	STUD	2	M8X1.25X30L	-	
540	279-32902-J1	INSULATOR CP	1	W/GASKET	-	
550	279-35903-J3	GASKET2(INSULATOR)	1	T=0.5	-	
560	279-35902-J3	GASKET1(INSULATOR)	1	T=0.5	-	
570	002-38060-00	FLANGE NUT	2	M6X1.0X13DX6H	-	
580	011-00600-50	FLANGE BOLT	1	M6X1.0X13DX20L	-	
620	279-39001-01	BRACKET(A/C) CP	1		-	
850	279-32760-08	RUBBER PIPE	1	8DX11DX115L	-	085-10800-00
855	279-69001-03	SPONGE PROTECTOR	1	13DX21D	-	

FIG. 317

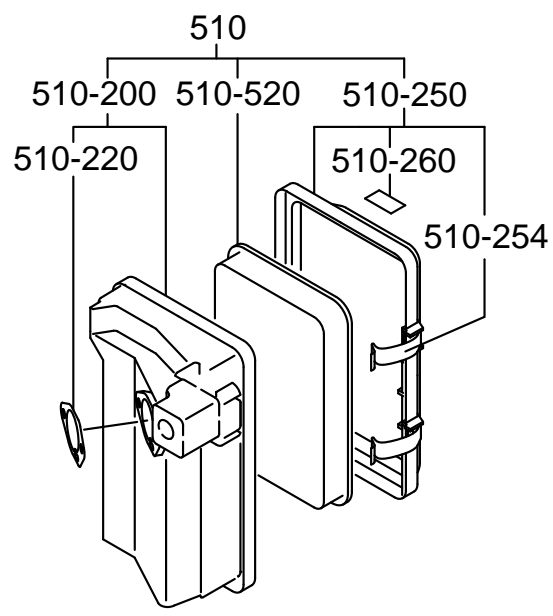

REF.	PART NUMBER	PART NAME	QTY	R E M A R K S	CODE NO.	NTERCHANGE P/NC
510	279-32623-10	AIR CLEANER AY	1	GENERATOR	-	
-200	279-32635-18	CLEANER BODY COMP	1		-	
-220	279-32650-18	GASKET	1		-	
-250	279-32646-08	COVER COMP	1		-	
-254	279-32683-08	CLIP 4	2	SK5 GEOMET+PLUS	-	
-260	073-20044-30	LABEL(CHOKE)	1	14X28 ILLUST	-	
-520	279-32609-07	ELEMENT SET	1	GENERATOR	-	

FIG. 400

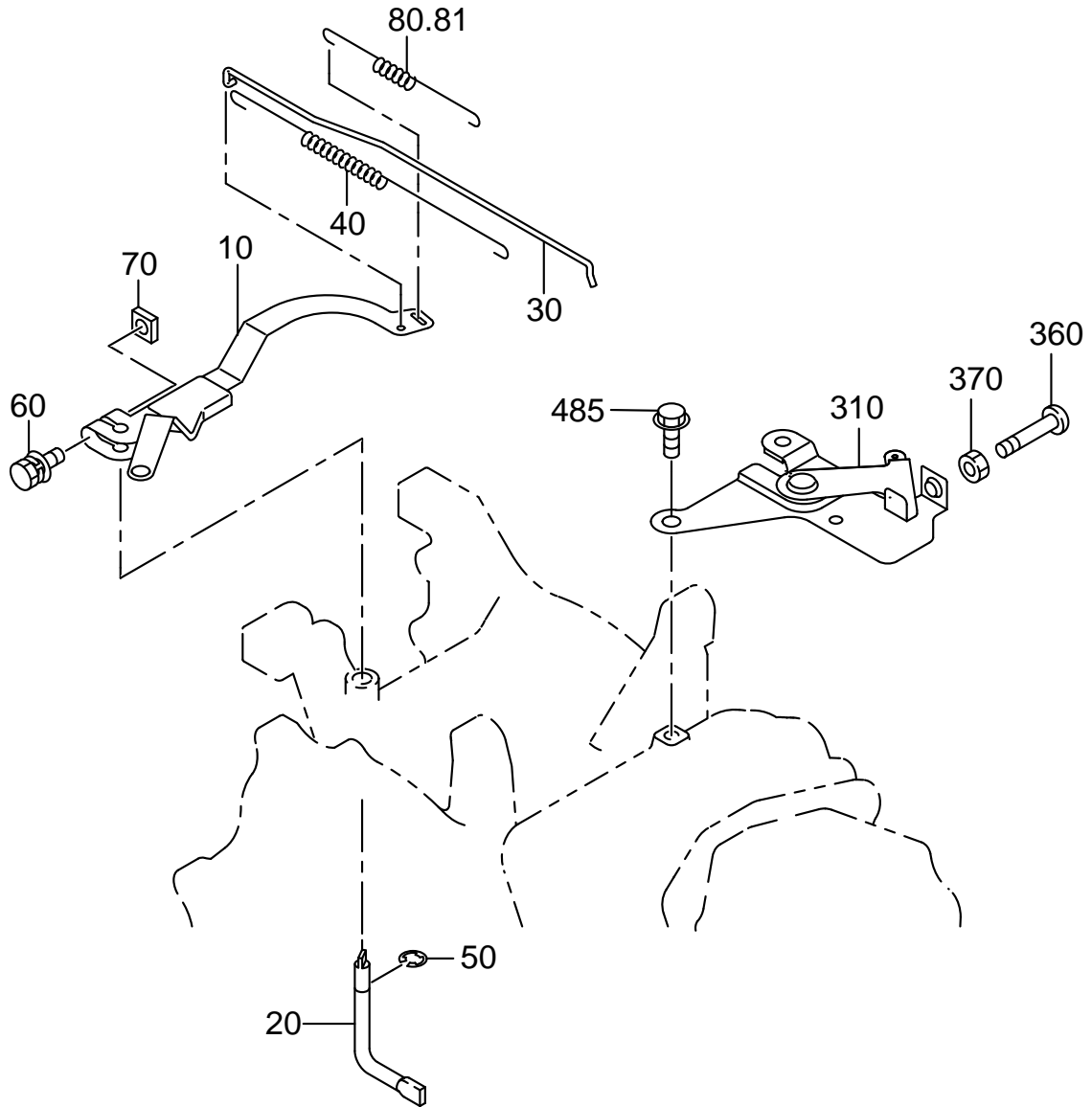

REF.	PART NUMBER	PART NAME	QTY	R E M A R K S	CODE NO.	NTERCHANGE P/NC
10	279-42302-61	GOVERNOR LEVER CP	1		-	
20	277-42201-33	GOVERNOR SHAFT	1		-	
30	279-42702-11	GOVERNOR ROD CP	1		-	
40	277-42801-23	ROD SPRING	1	7DX0.5DX182L N=16	-	
50	003-13050-00	CLIP	1	5DX11DX0.6T	-	
60	013-00602-40	BOLT AND WASHER AY	1	M6X1.0X25L W/TWO W	-	
70	018-60600-20	NUT	1	M6X1.0X4.9H SQUARE	-	
80	279-42502-63	GOVERNOR SPRING	1	7.5DX0.7DX115L N=19	-	
310	277-46501-11	SPEED CONTROL CP	1		-	
360	004-31064-00	SCREW	1	M6X1.0X40L	-	
370	002-17060-00	NUT	1	M6X1.0X5H	-	
485	011-00600-20	FLANGE BOLT	2	M6X1.0X14DX12L	-	

FIG. 500

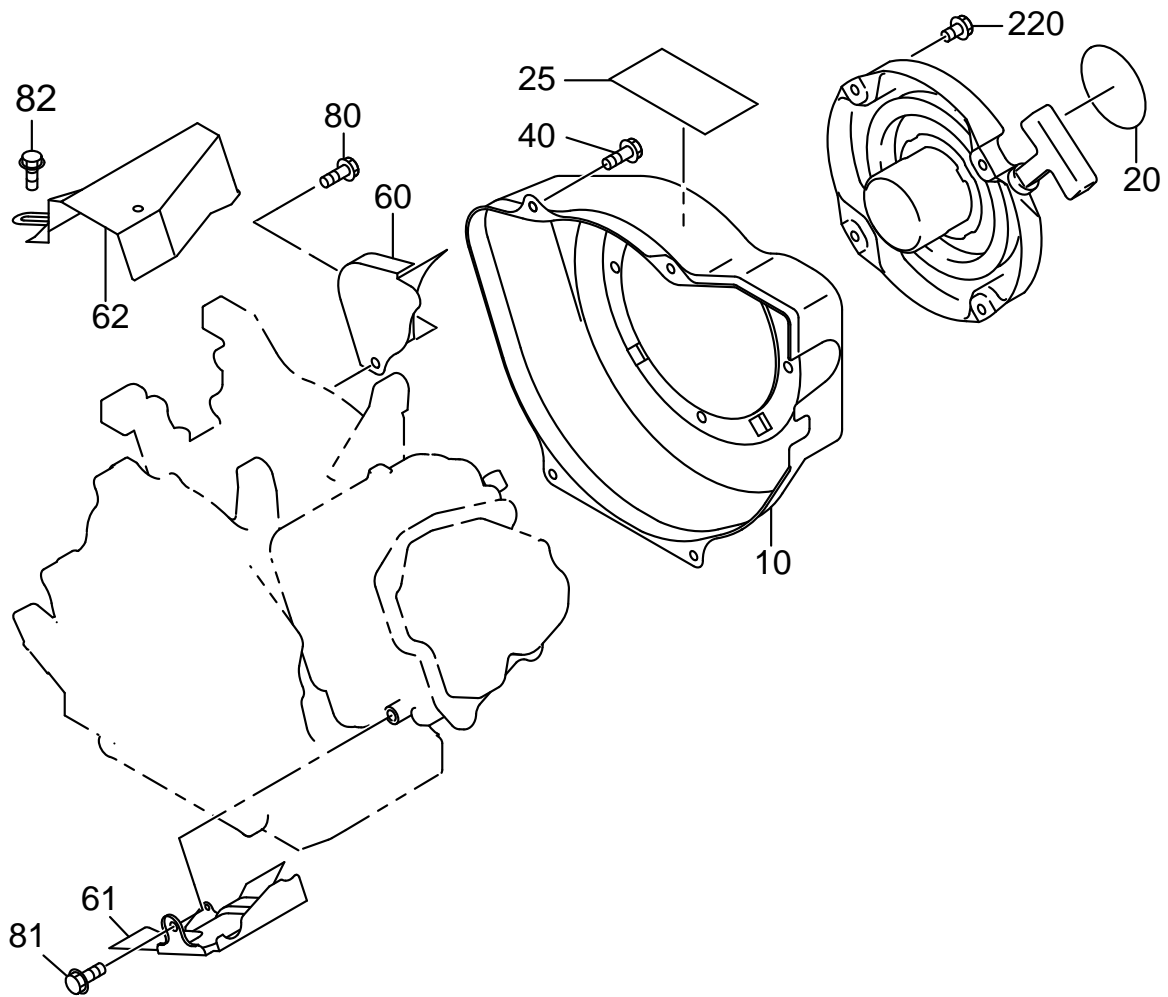

REF.	PART NUMBER	PART NAME	QTY	R E M A R K S	CODE NO.	NTERCHANGE P/NC
10	279-51226-01	BLOWER HOUSING CP	1	CANARY YELLOW	-	
20	073-20054-70	LABEL(TRADE MARK)	1	60D	-	
25	073-20051-81	LABEL(WARNING)	1	42X104 ENGLISH	-	
40	011-00600-30	FLANGE BOLT	4	M6X1.0X14DX14L	-	
60	279-52711-11	BAFFLE 1(CASE) CP	1		-	
61	279-52702-13	BAFFLE 2(HEAD)	1		-	
62	277-55001-21	DUCT (CASE) CP	1		-	
80	001-65081-20	BOLT	1	M8X1.25X12L	-	
81	011-00600-20	FLANGE BOLT	1	M6X1.0X14DX12L	-	
82	011-00600-20	FLANGE BOLT	3	M6X1.0X14DX12L	-	
220	011-00600-10	FLANGE BOLT	4	M6X1.0X14DX8L	-	

FIG. 520

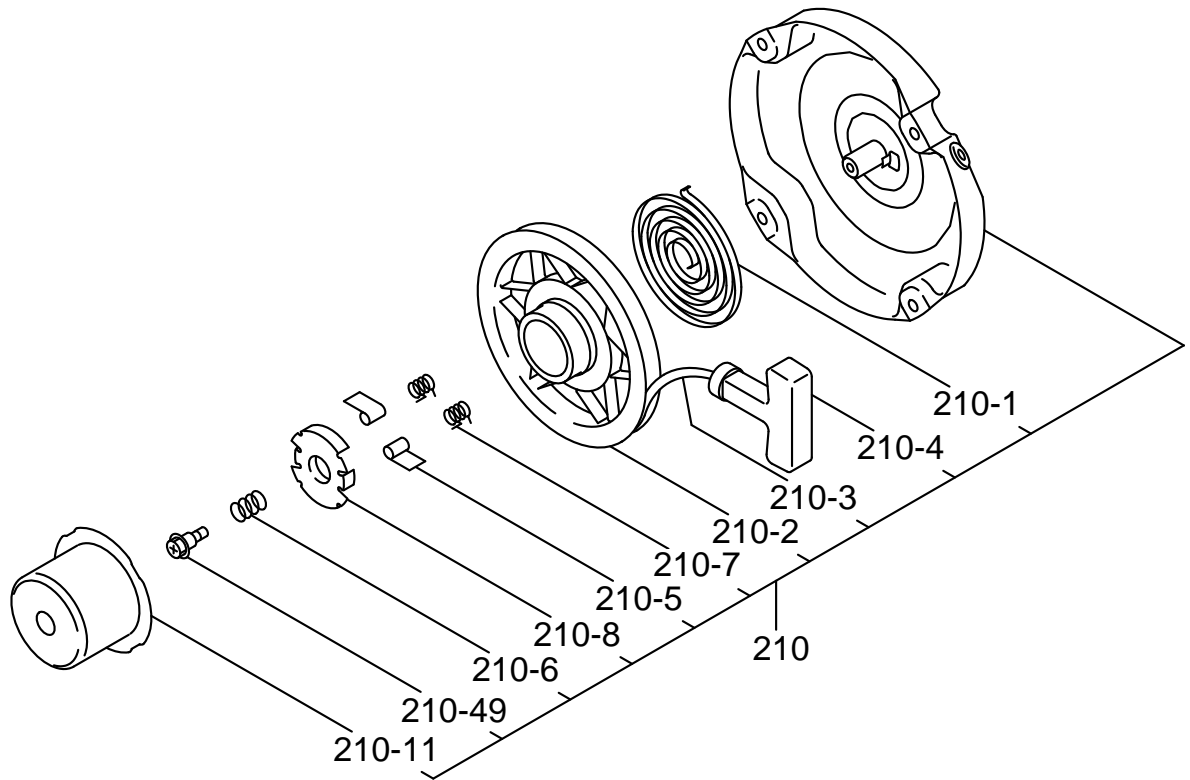

REF.	PART NUMBER	PART NAME	QTY	R E M A R K S	CODE NO.	NTERCHANGE P/NC
210	279-50202-00	RECOIL STARTER AY	1	170PD	-	
- 1	226-50716-08	SPIRAL SPRING	1		-	
- 2	279-50120-08	REEL	1		-	
- 3	279-50110-08	STARTER ROPE	1		-	
- 4	226-50701-08	STARTER KNOB	1		-	
- 5	279-50125-08	RACHET	2		-	
- 6	226-50731-08	FRICTION SPRING	1		-	
- 7	226-50752-08	RATCHET SPRING	2		-	
- 8	226-50741-08	FRICTION PLATE	1		-	
- 11	279-50145-08	STARTER PULLEY	1		-	
- 49	226-50753-18	CENTER SCREW	1		-	

FIG. 600

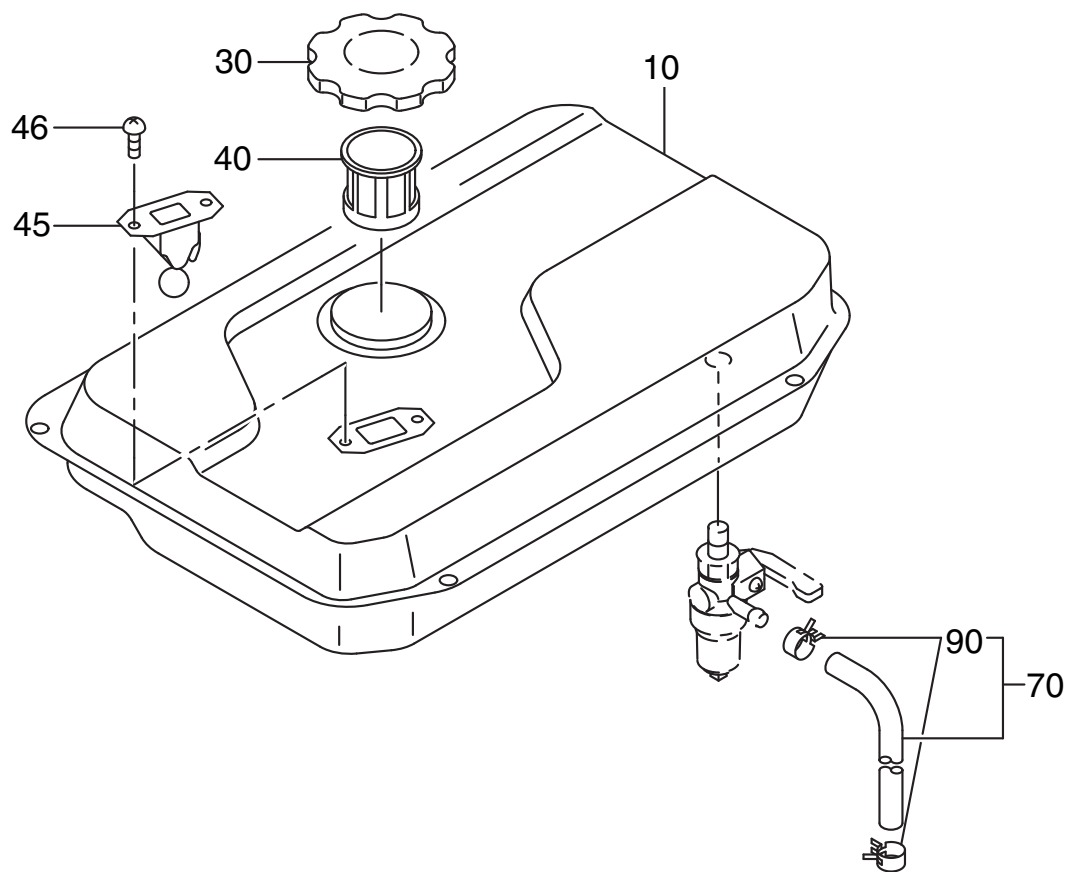

REF.	PART NUMBER	PART NAME	QTY	R E M A R K S	CODE NO.	NTERCHANGE P/NC
10	270-61718-01	FUEL TANK CP	1	16L W/GAG CANARY YEL	-	
30	043-05900-11	FUEL TANK CAP AY	1	59DX102DX15H	-	
40	064-15400-11	FUEL FILTER	1	54DX58DX48H	-	
45	064-80018-00	FUEL GAUGE CP	1		-	
46	014-50500-40	SCREW(COUNTER HEAD)	2	M5X0.8X10L	-	
70	267-62605-11	FUEL PIPE CP	1		-	
90	X56-11100-60	HOSE CLAMP	2	11.5DX8BX0.7T	-	

FIG. 630

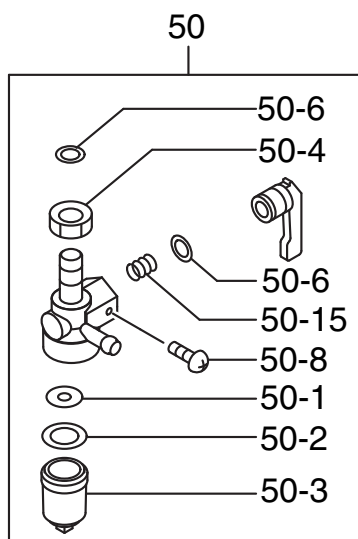

REF.	PART NUMBER	PART NAME	QTY	R E M A R K S	CODE NO.	NTERCHANGE P/NC
50	064-20100-01	FUEL STRAINER AY	1		-	
- 1	064-20041-10	FILTER	1		-	
- 2	064-20014-30	RUBBER PACKING	1		-	
- 3	064-20014-10	CUP	1		-	
- 4	064-20100-30	LOCK NUT	1		-	
- 6	064-20003-30	O-RING	2		-	
- 8	064-20027-90	BOLT	1		-	
- 15	064-20032-30	SPRING	1		-	

FIG. 640

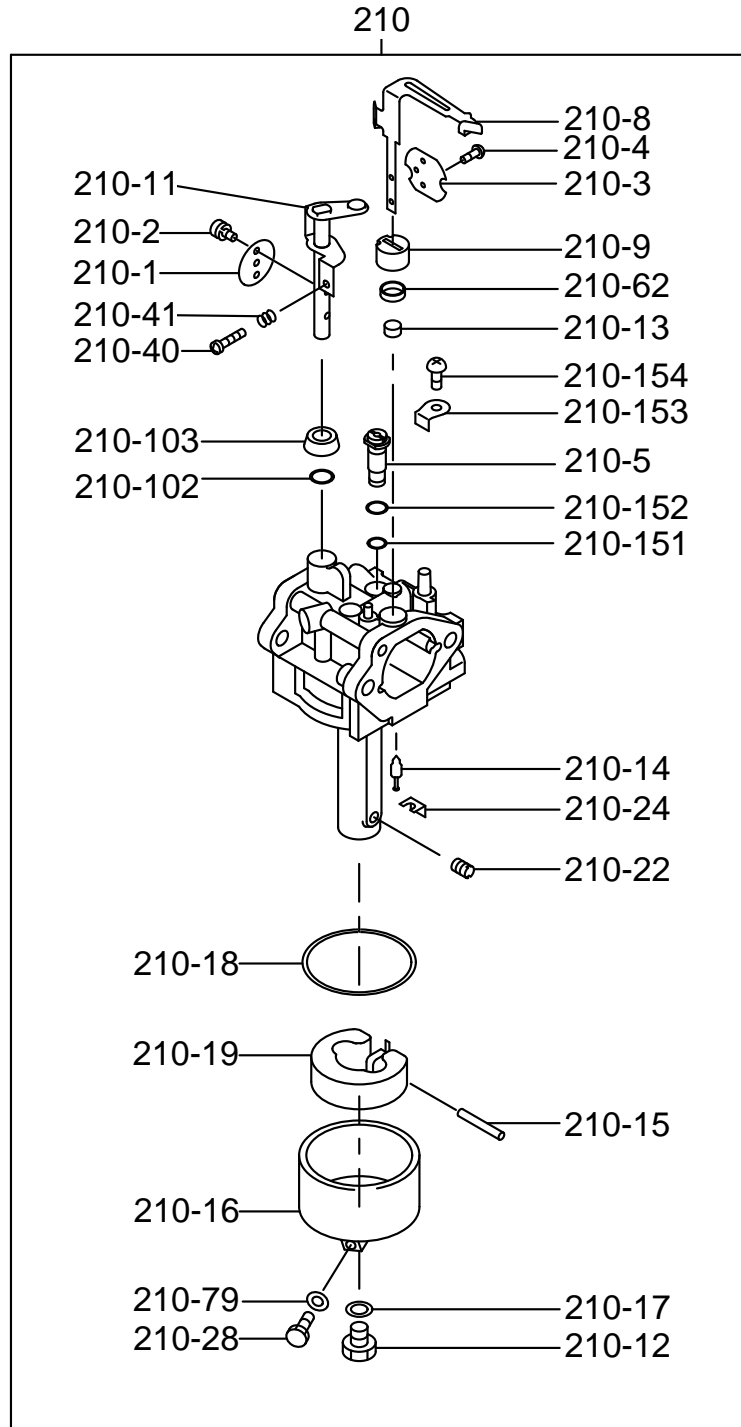

REF.	PART NUMBER	PART NAME	QTY	R E M A R K S	CODE NO.	INTERCHANGE P/NC
210	279-62364-00	CARBURETOR AY	1		-	
- 1	279-62536-08	THROTTLE VALVE	1		-	
- 2	209-62351-08	SCREW	1		-	
- 3	279-62528-08	CHOKE VALVE	1		-	
- 4	237-62451-08	SCREW	2		-	
- 5	279-62422-08	PILOT JET	1	#38.8	-	
- 8	279-62523-08	CHOKE LEVER	1		-	
- 9	279-62554-08	RING	1		-	
- 11	279-62533-08	THROTTLE SHAFT-A	1		-	
- 12	150-62358-08	BOLT	1		-	
- 13	277-62571-08	RING	1		-	
- 14	224-62305-08	NEEDLE VALVE	1		-	
- 15	214-62515-08	PIN	1		-	
- 16	279-62506-08	FLOAT BODY-A	1		-	
- 17	207-62345-08	INSERT WASHER	1		-	
- 18	206-62540-08	PACKING	1		-	
- 19	234-62506-08	FLOT-A	1		-	
- 22	279-62408-08	MAIN JET	1	#92.5	-	
- 24	226-62701-18	CLIP	1		-	
- 28	279-62361-08	BOLT	1		-	
- 40	106-62556-08	SCREW	1		-	
- 41	283-62357-08	SPRING	1		-	
- 62	236-62680-08	SEAL	1		-	
- 79	279-62541-08	WASHER	1		-	
-102	246-62390-08	SEAL	1		-	
-103	279-62551-08	RING	1		-	
-151	106-62384-08	O-RING	1		-	
-153	279-62360-08	PLATE	1		-	
-154	279-62351-08	SCREW	1		-	

FIG. 700

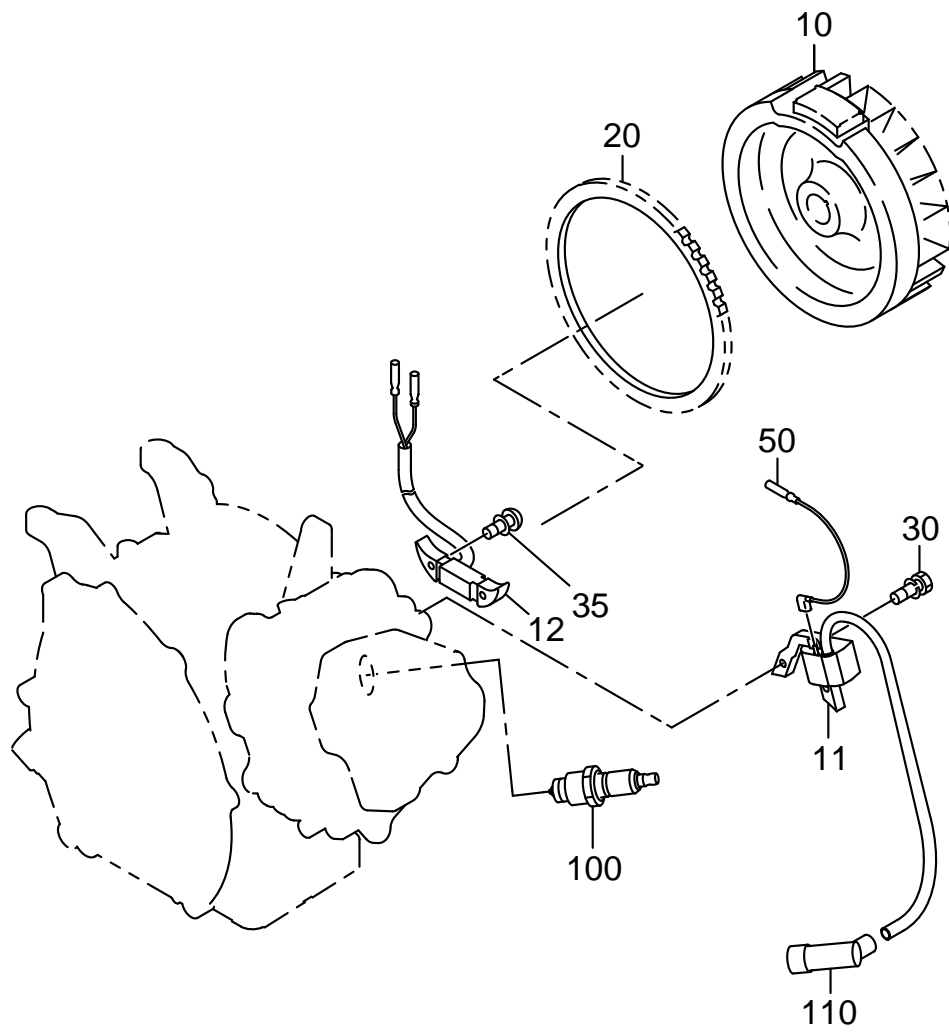

REF.	PART NUMBER	PART NAME	QTY	R E M A R K S	CODE NO.	NTERCHANGE P/NC
10	279-79241-01	FLYWHEEL CP	1	MARK FB AP02	-	
11	279-79430-01	IGNITION COIL CP	1	MARK AB	-	
12	279-79301-01	LAMP COIL CP	1		-	
30	001-14062-50	BOLT AND WASHER AY	2	M6X1.0X25L W/W,SW	-	
35	001-13062-00	BOLT AND WASHER AY	2		-	
50	277-73102-H1	WIRE 2 CP	1	L=360 BLACK	-	
100	065-01401-50	SPARK PLUG	1	NGK BR6HS	-	
110	065-50002-70	SPARK PLUG CAP	1		-	

FIG. 760

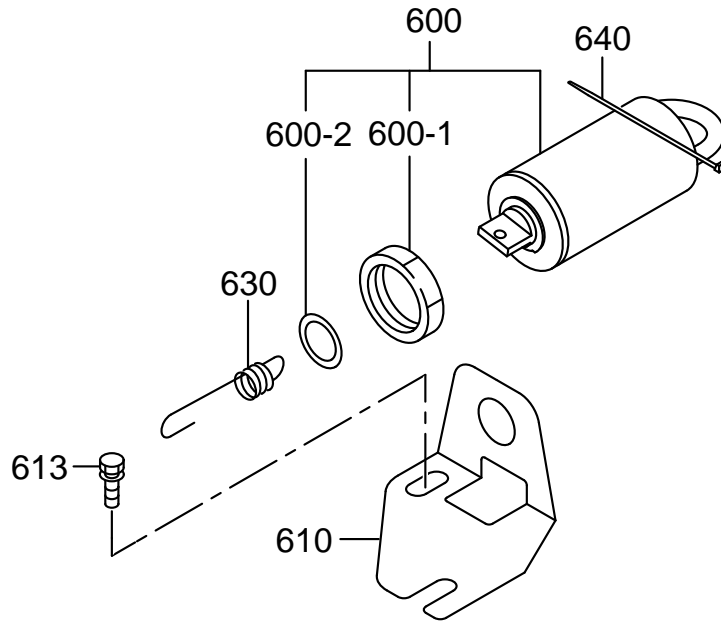

REF.	PART NUMBER	PART NAME	QTY	R E M A R K S	CODE NO.	NTERCHANGE P/NC
600	246-77303-01	SOLENOID CP	1		-	
- 1	224-76506-08	NUT	1		-	
- 2	224-76507-08	WASHER	1		-	
610	279-76501-11	BRACKET(SOLENOID) CP	1		-	
613	001-14062-00	BOLT AND WASHER AY	2	M6X1.0X20L W/W,SW	-	
630	279-78201-13	SPRING(SOLENOID)	1	9DX1.6DX54L N=12	-	
640	056-30000-10	WIRE BAND	1	4.5BX1.2TX200L	-	

FIG. 770

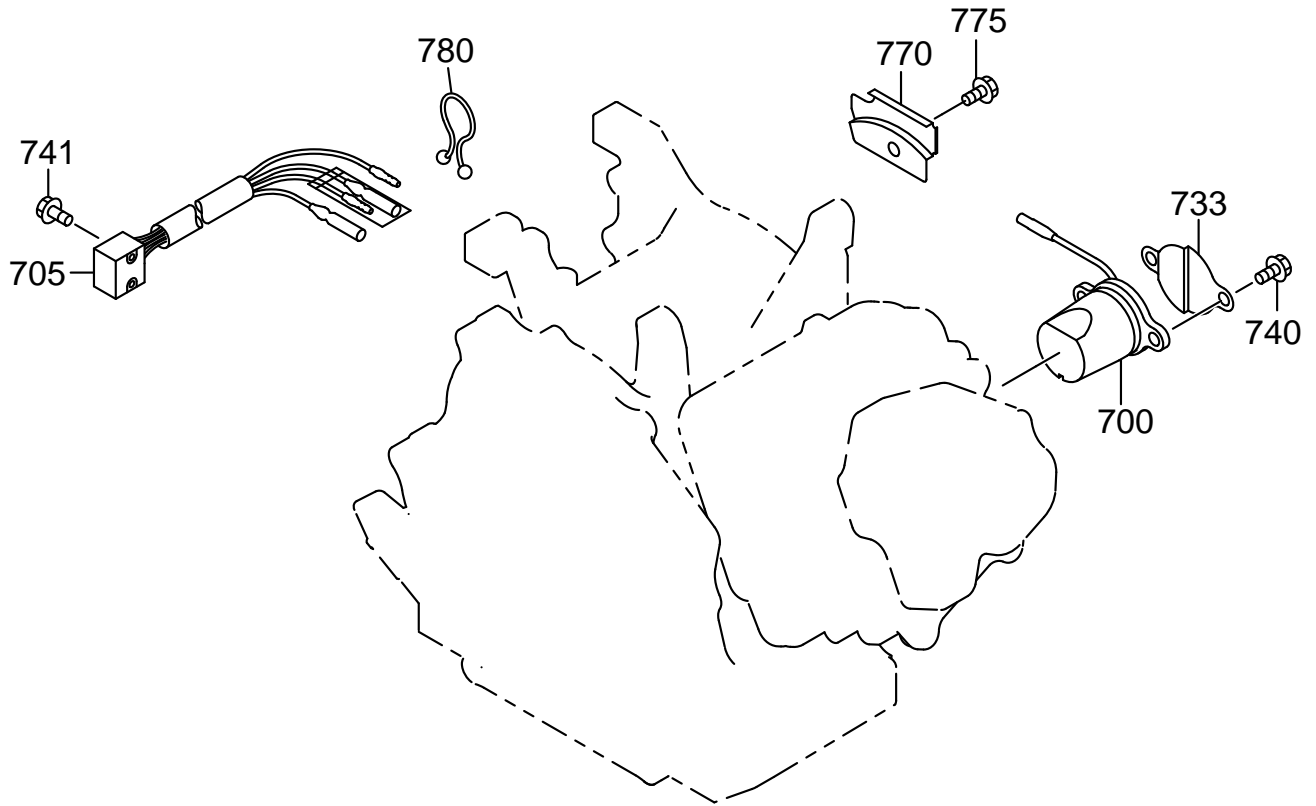

REF.	PART NUMBER	PART NAME	QTY	R E M A R K S	CODE NO.	NTERCHANGE P/NC
700	279-76301-51	OIL SENSOR CP	1		-	
705	KU3-11070-01	FLOAT C/U CP4	1		-	
733	277-75801-03	SHIELD PLATE(O/S)	1		-	
740	013-00602-60	BOLT AND WASHER AY	2	M6X1.0X16L W/SW	-	
741	015-00400-90	TAPPING SCREW	2	M4X12L	-	
770	279-75501-13	WIRE CLAMP	1		-	
775	015-20600-50	TAPPING BOLT	1	M6X13DX10L	-	
780	056-90000-20	PURSE LOCK	1		-	

FIG. 900

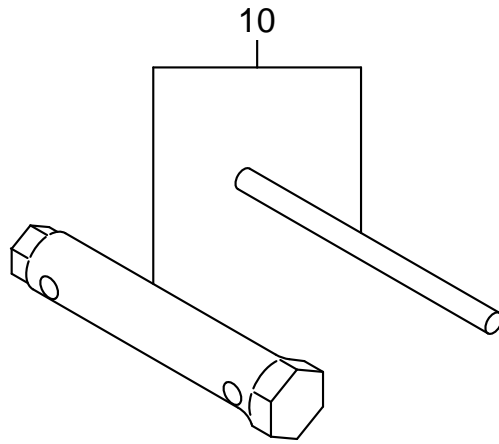

REF.	PART NUMBER	PART NAME	QTY	REMARKS	CODE NO.	INTERCHANGE P/NC
10	277-90301-H0	ACCESSORY TOOL KIT	1		-	

FIG. 2200

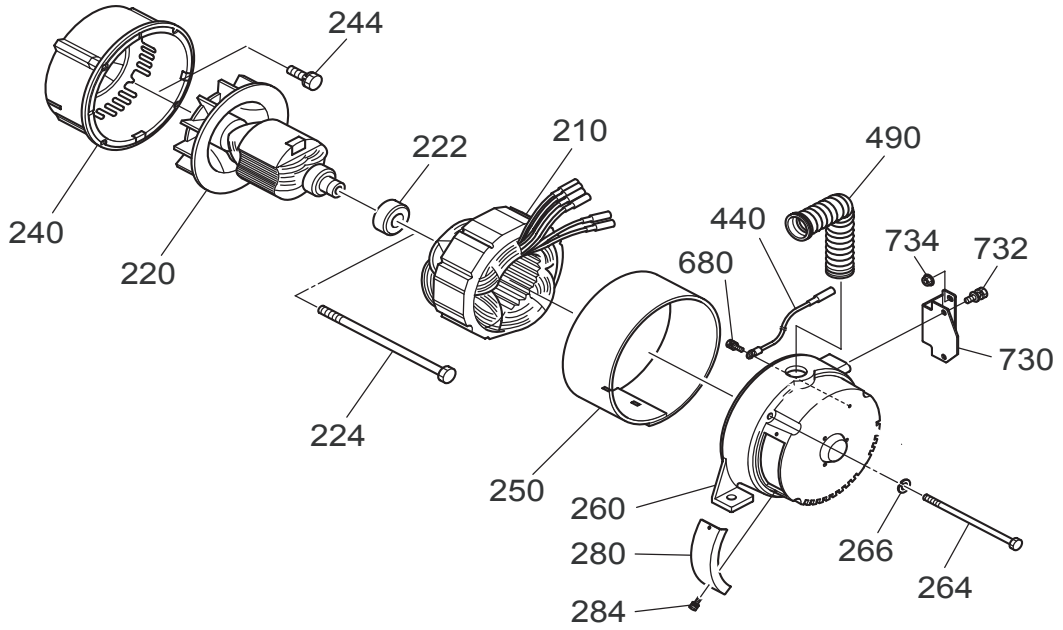

REF.	PART NUMBER	PART NAME	QTY	R E M A R K S	CODE NO.	INTERCHANGE P/NO.
210	35C-51004-01	STATOR CP	1		-	
220	35C-51001-01	ROTOR CP	1		-	
222	35C-55001-01	BEARING	1		-	
224	35C-54001-01	THROUGH BOLT	1		-	
240	35C-52001-01	FRONT COVER	1		-	
244	359-59935-08	BOLT & WASHER AY	4	M8X20	-	
250	35C-55012-01	STATOR COVER	1		-	
260	35C-52002-01	REAR COVER	1		-	
264	35C-54002-01	COVER BOLT	4	M8	-	
266	003-20080-00	SPRING WASHER	4	M8	-	
280	354-54513-08	BRUSH COVER	1		-	
284	30A-71202-03	SCREW & WASHER AY	2	M5X12	-	
440	35C-53002-01	WIRE CP	1		-	
490	353-57506-18	BUSHING	1		-	
680	392-49986-08	SCREW	1	M4X6L	-	
730	35C-63001-01	MUFFLER BRACKET	1		-	
732	359-59935-08	BOLT & WASHER AY	2	M8X20	-	
734	002-38080-00	FLANGE NUT	8	M8X1.25	-	

FIG. 2300

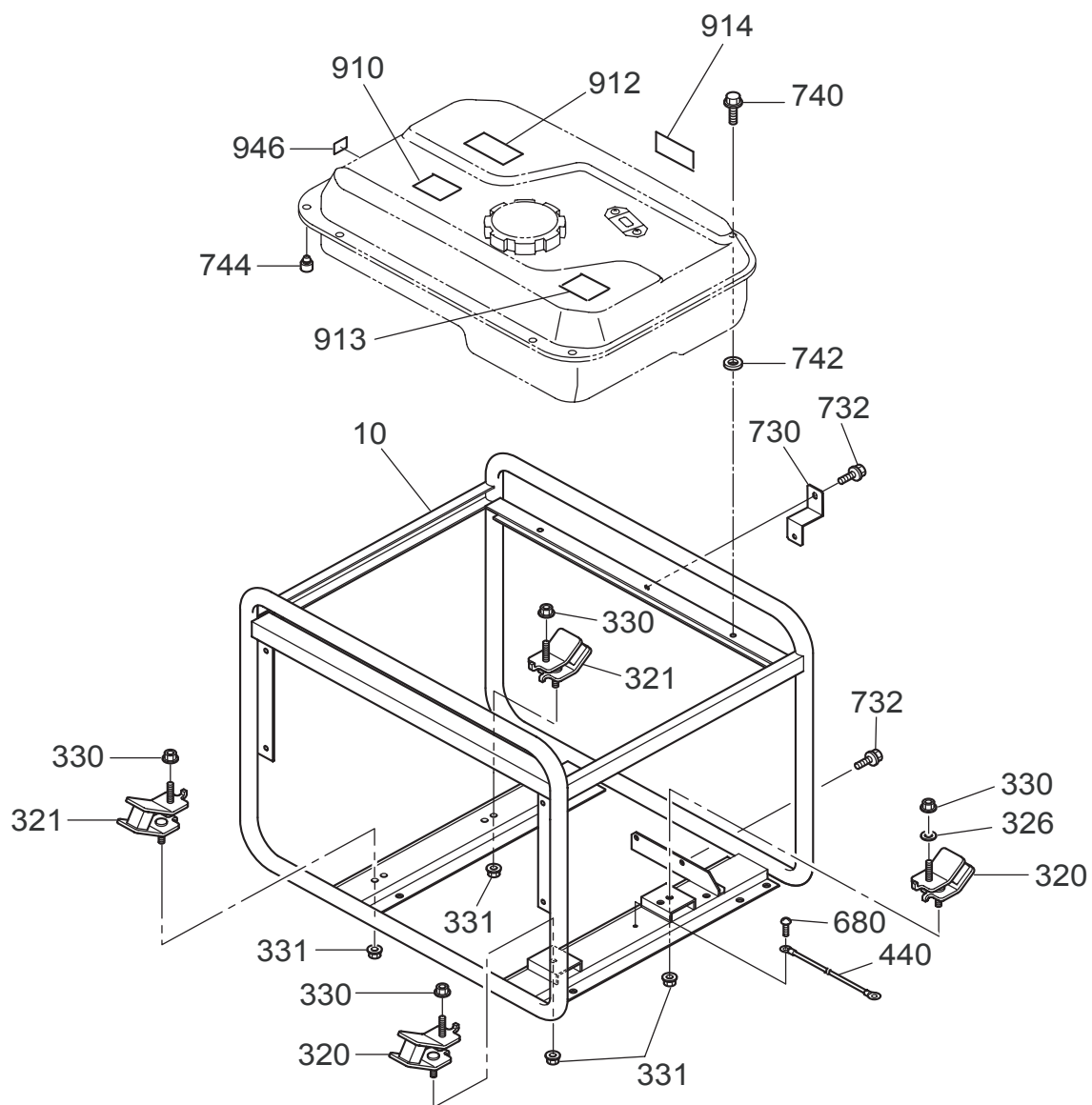

REF.	PART NUMBER	PART NAME	QTY	R E M A R K S	CODE NO.	INTERCHANGE P/NO.
10	35C-61001-01	PIPE FRAME CP	1		-	
320	35C-62001-01	RUBBER MOUNT UN	2		-	
321	35C-62002-01	RUBBER MOUNT UN	2		-	
326	003-10100-00	WASHER	1	M10	-	
330	002-38100-00	FLANGE NUT	4	M10X1.5	-	
331	002-38080-00	FLANGE NUT	4	M8X1.25	-	
440	35C-64001-01	EARTH CORD	1		-	
680	392-49987-08	SCREW & WASHER AY	1	M5X8	-	
730	35C-63003-01	BRACKET,MUFF.COVER	1		-	
732	35A-64001-01	FLANGE BOLT	9	M6X10	-	
740	011-00602-20	FLANGE BOLT	2	M6X21	-	
742	391-39000-13	RUBBER WASHER	2		-	
744	35C-62003-01	RUBBER MOUNT	2		-	
910	073-20055-80	LABEL(CAUTION)	1	CPSC	-	
912	388-93003-03	LABEL(CAUTION)	1		-	
913	073-20045-10	LABEL(SYMBOL, TANK)	1		-	
914	073-20048-60	LABEL(HOT&GAS)	1		-	
946	073-20050-80	LABEL(F.STRAINER)	1		-	

FIG. 2400

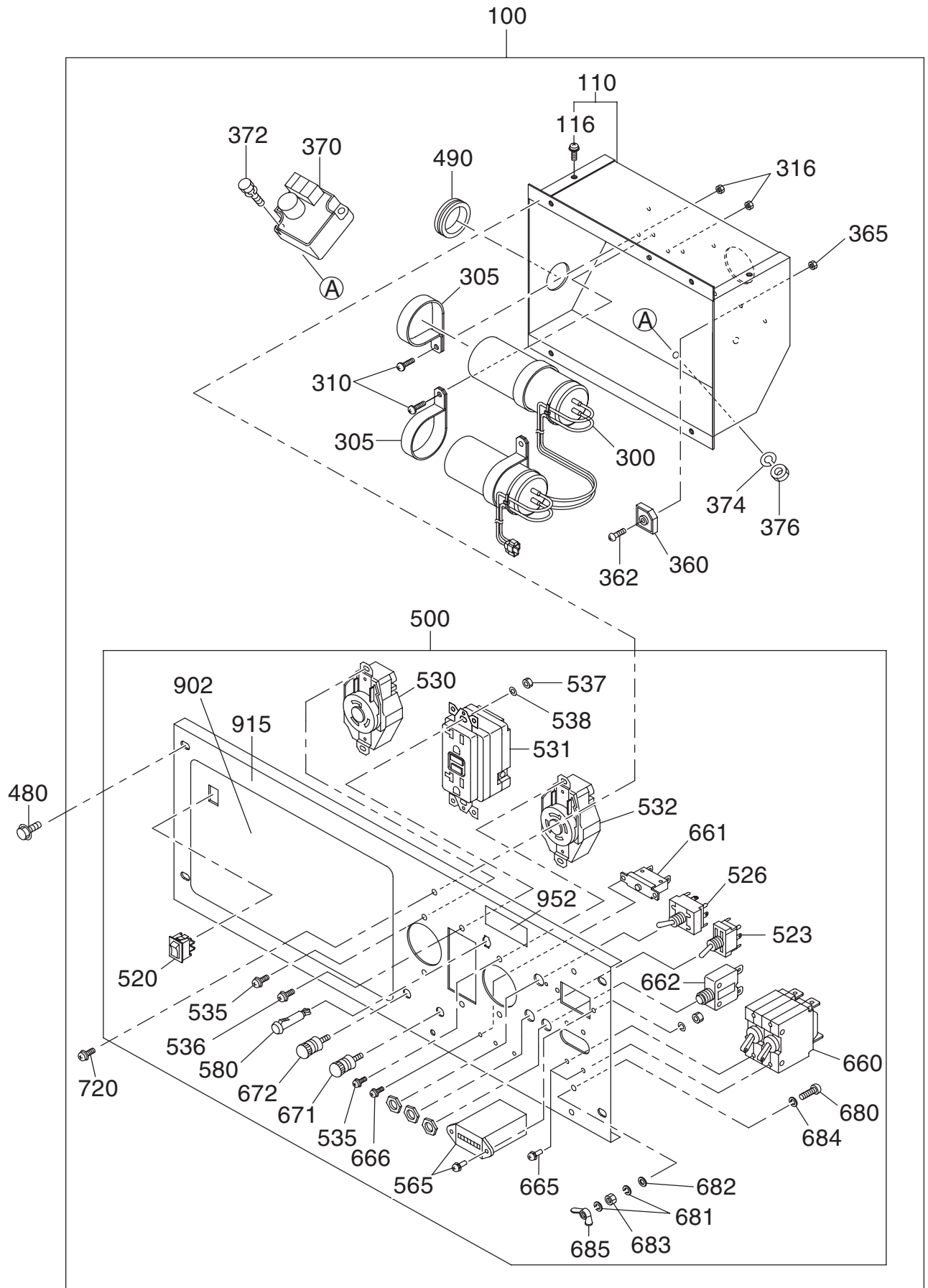

REF.	PART NUMBER	PART NAME	QTY	R E M A R K S	CODE NO.	INTERCHANGE P/NO.
100	35C-70107-00	CONTROL BOX AY	1		-	
110	35C-71102-02	CONTROL BOX UN	1		-	
116	359-59929-08	SCREW & WASHER AY	4		-	
300	35C-72001-03	CONDENSER CP	1	30+20 μ F	-	
305	30G-47605-08	CONDENSER HOLDER	4		-	
310	390-49972-08	SCREW	4	M4X12	-	
316	002-17040-00	NUT	4		-	
360	353-45804-08	DIODE STACK AY	1		-	
362	004-36042-00	SCREW AND WASHER	1	M4X20	-	
365	002-17040-00	NUT	1	M4	-	
370	KU3-11015-01	IDLE C/U CP (150V)	1		-	
372	004-35062-00	SCREW & WASHER AY	2	M6X20	-	
374	003-20060-00	SPRING WASHER	2	M6	-	
376	002-17060-00	NUT	2	M6	-	
480	35C-72014-03	FLANGE BOLT	4	M6X1.0X14DX12L	-	
490	389-89001-03	GROMMET	1		-	
500	35C-70207-00	PANEL A AY	1		-	
520	35A-72002-03	ROCKER SWITCH	1		-	
523	344-45615-08	AUTO IDLE SWITCH	1		-	
526	355-45613-11	SWITCH AY(9P)	1		-	
530	35B-72003-03	AC RECEPTACLE	1	250V/30A	-	
531	388-85003-01	AC RECEPTACLE	1	125V-20A GFCI	-	
532	35C-72005-03	AC RECEPTACLE	1		-	
535	31C-79001-03	SCREW & WASHER AY	4	M3.5X10	-	
536	351-49920-08	SCREW & WASHER AY	2	M4X10	-	
537	002-17040-00	NUT	2		-	
538	003-10040-00	WASHER	2		-	
565	393-40651-08	HOUR METER	1	60HZ	-	
580	30G-45308-08	LAMP	1		-	
660	35C-72002-03	BREAKER	1	18A	-	
661	352-45620-08	CIRCUIT BREAKER	1		-	
662	35C-72006-03	BREAKER	1	30A	-	
665	31B-79011-03	SCREW & WASHER AY	4	M3X5	-	
666	351-49921-08	SCREW & WASHER AY	2	M3X6	-	
671	363-45701-08	TERMINAL BOLT	1	RED 20A	-	
672	363-45700-08	TERMINAL BOLT	1	BLACK 20A	-	
680	356-49956-08	SCREW	1	M5X20	-	
681	332-00050-08	SPRING WASHER	2		-	
682	353-49903-08	WASHER	1		-	
683	353-49902-08	NUT	1		-	
684	372-59950-08	LOCK WASHER	1	M5	-	
685	353-49901-08	WING NUT	1	M5	-	
720	31B-79012-03	BOLT AND WASHER AY	4	M5X12	-	
902	35C-71209-02	LABEL(BRAND)	1		-	
915	35C-71208-02	LABEL(PANEL)	1		-	
952	391-93014-03	LABEL,GROUND	1		-	