



# PARTS CATALOG

# Robin

## Pump

Model

# *PKX301T*

Spec. No. PKX301T0370  
(EX270D10040)

 **FUJI HEAVY INDUSTRIES LTD.**  
INDUSTRIAL PRODUCTS COMPANY

ISSUE EMD - PP5880
ISSUE DATE 2003.3

# HOW TO USE THIS PARTS CATALOG

REF.	PART NUMBER	PART NAME	QTY	REMARKS	CODE NO. FROM-TO	INTERCHANGEABLE PART NUMBER	UNIT PRICE	FIG.
10	281-60101-01	FUEL TANK CP	1	2.8L NEW R YELLOW	-			600
20	073-20044-50	LABEL(CAUTION)	1	38X70	-			600
30	043-04300-15	FUEL TANK CAP CP	1	43DX68DX14H	5296-			600
	043-04301-00	FUEL TANK CAP CP	1		-5295			600
40	064-13600-10	FUEL FILTER	1	36DX46DX43H	-			600
50	064-20064-00	FUEL STRAINER AY	1		-			630
- 1	064-20064-20	FILTER	1		-			630
- 2	064-20064-10	PACKING	1		-			630
- 3	064-20042-10	CUP, STRAINER	1		-			630

- ① **SECTION NAME** ..... Parts are broadly classified according to their functions. Refer to section indexes(contents)for respective section name.
- ② **FIG.No**..... It indicates illustration number. FIG.No. with the same figure in the third of hundreds shows that it is in a group of the same section. FIG.No. illustrating the target part can be read in the right-end section of the list.
- ③④ **REF.No.** ..... It is a number to compare the part illustrated with the part number in the list.Serch for REF.No. in the list in the corresponding REF.No. in the illustration to determine the part number.  
Section ④ shows a 'SUB-ASSEMBLY PART' of section ③ which is indicated by the number led by '-' such as '-1','-2'.
- ⑤ **PART NUMBER** ..... It is the number assigned for sales unit.  
Use the PART No. when marking an order.
- ⑥ **PART NAME**..... It is designation of the part.
- ⑦ **Q'ty** ..... Quantity of part being employed for each product.
- ⑧ **REMARKS** ..... This gives a distinctive feature and/or a supplementary comment for the type,the specification, and the part concerned.
- ⑨ **INTERCHANGEABLE...** It shows part number(s) interchangeable for the part given in the section  
**PART NUMBER** ⑤.
- ⑩ **CODE No.** ..... It indicates history of progress in which improved parts have been introduced in the product.The CODE No. helps to identify PART No. being employed in the product concerned.

	—	The part has been employed in the product irrespective of CODE No.
	5296—	The part is employed in the products with CODE No. of 5296 and after this number.
	—5295	The part is employed in the products with CODE No. of 5295 and before this number.

FIG. 100

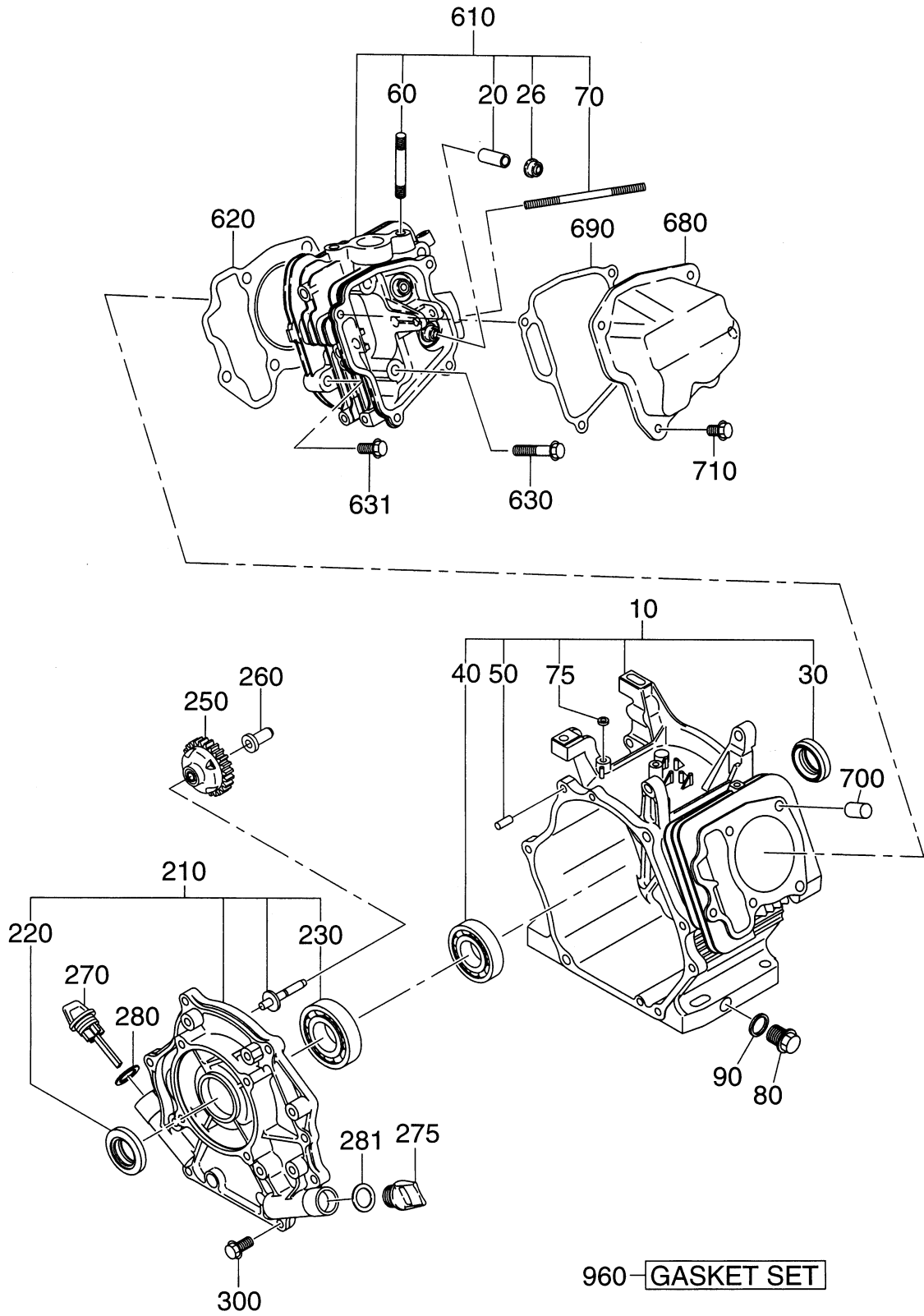
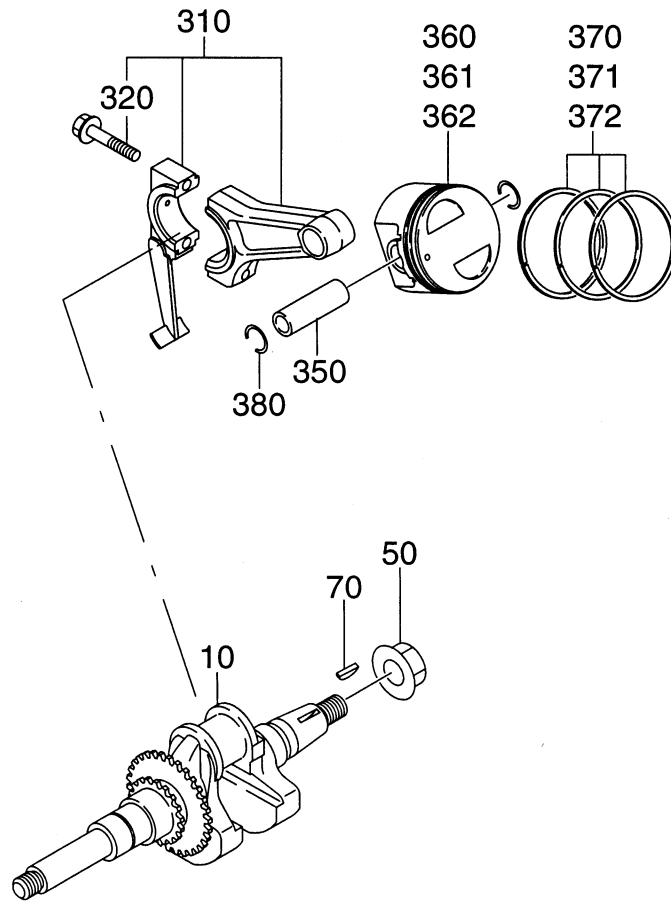

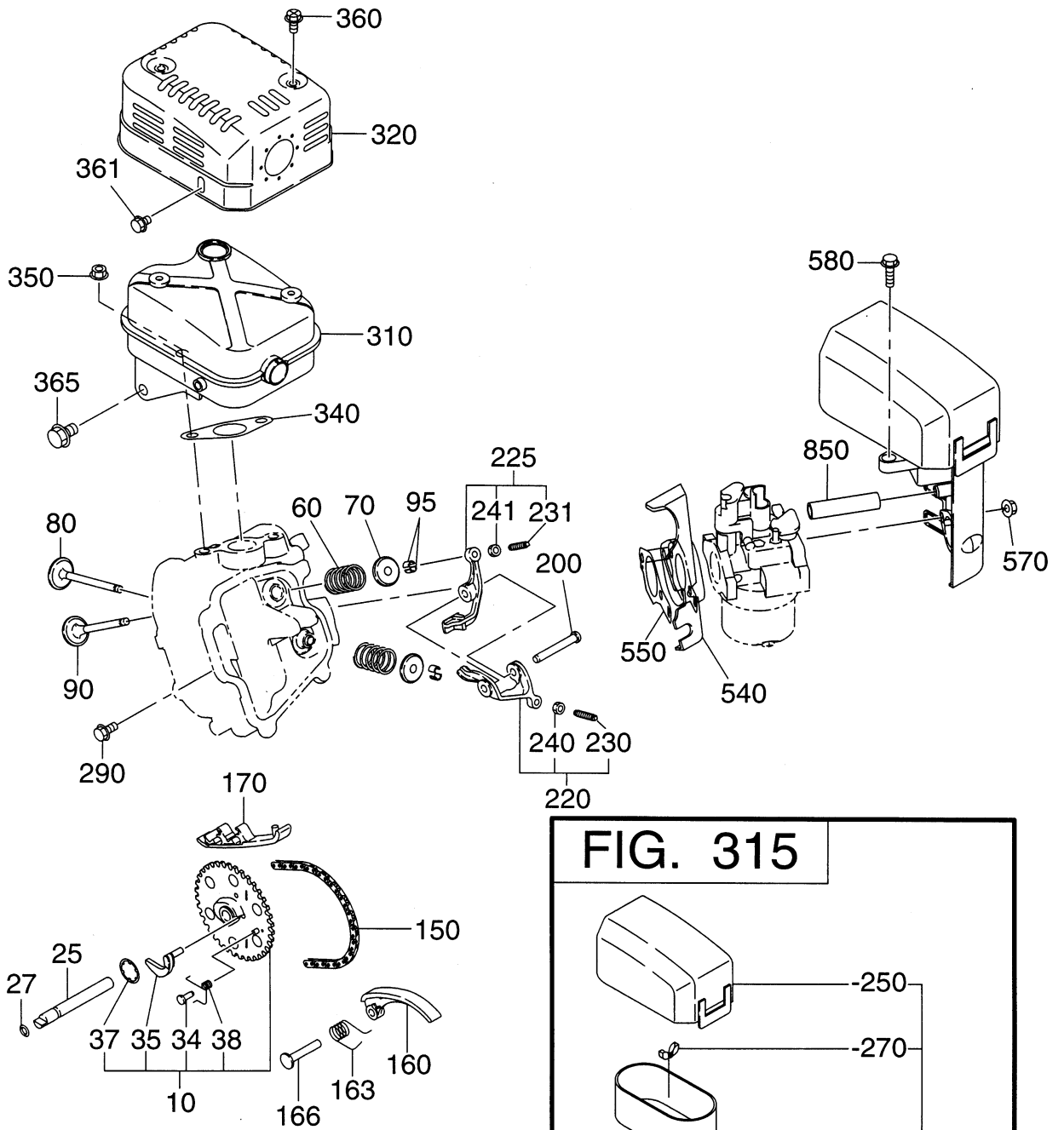

FIG. 200

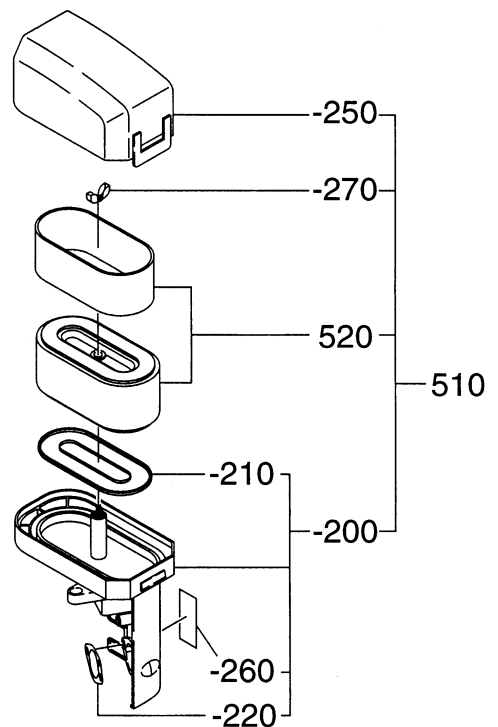



**FIG. 300**



**FIG. 315**



3 INTAKE EXHAUST

REF.	PART NUMBER	PART NAME	QTY	REMARKS	CODE NO. FROM-TO	INTERCHANGEABLE PART NUMBER	UNIT PRICE	FIG.
10	279-31601-01	CAM SHAFT CP	1	93DX2. 9B N=44	-			300
25	277-35101-03	PIN(CAM SHAFT)	1	9DX78. 5L	-			300
27	024-00600-10	O RING	1	5. 8DX9. 6D	-			300
34	277-38601-03	PIN(SPRING)	1	4DX8DX9L	-			300
35	279-36401-03	RELEASE LEVER	1		-			300
37	277-36501-03	CLIP	1	13. 8DX20. 3DX0. 4T	-			300
38	277-38701-03	RETURN SPRING	1		-			300
60	279-33601-03	VALVE SPRING	2		-			300
70	269-33701-03	SPRING RETAINER	2		-			300
80	279-33401-13	INTAKE VALVE	1	28. 5DX5. 5DX67. 8L	-			300
90	279-33501-13	EXHAUST VALVE	1	26. 5DX5. 5DX67. 8L	-			300
95	132-10KA0-31	COLLET-VALVE	4		-			300
150	279-35601-01	TIMING CHAIN CP	1	100 LINK	-			300
160	277-36911-03	TENTIONER	1		-			300
163	277-37101-03	SPRING(TENTIONER)	1		-			300
166	277-36902-03	PIN(TENTIONER)	1	6DX13DX34L	-			300
170	277-36913-13	CHAIN GUIDE	1		-			300
200	277-35001-23	PIN(ROCKER)	1	6DX9DX41L	5692-			300
	277-35001-13	PIN(ROCKER)	1	6DX9DX41L	-5691	277-35001-23		300
220	277-36101-00	ROCKER ARM(IN) AY	1		-			300
225	277-36102-00	ROCKER ARM(EX) AY	1		-			300
230	014-90500-10	ADJUST SCREW	1	M5X0. 5X23L	-			300
231	014-90500-10	ADJUST SCREW	1	M5X0. 5X23L	-			300
240	017-00500-20	NUT	1	M5X0. 5X4. 1H	-			300
241	017-00500-20	NUT	1	M5X0. 5X4. 1H	-			300
290	011-00600-20	FLANGE BOLT	1	M6X1. 0X14DX12L	-			300
310	279-30101-21	MUFFLER CP	1		-			300
320	279-34201-11	MUFFLER COVER CP	1		-			300
340	277-35201-03	GASKET(MUFFLER)	1	T=0. 2 26D 9DX58P	-			300
350	980-20082-80	FLANGE NUT	2		-			300
360	015-20600-90	TAPPING BOLT	2	M6X13DX10L	-			300
361	011-00600-10	FLANGE BOLT	1	M6X1. 0X14DX8L	-			300
365	011-00801-50	FLANGE BOLT	1	M8X1. 25X16DX12L	-			300
510	279-32612-00	AIR CLEANER AY	1	DUAL	-			315
-200	279-32631-08	ELBOW COMP, AIR/C	1		-			315
-210	279-32720-08	PACKING	1		-			315





FIG. 400

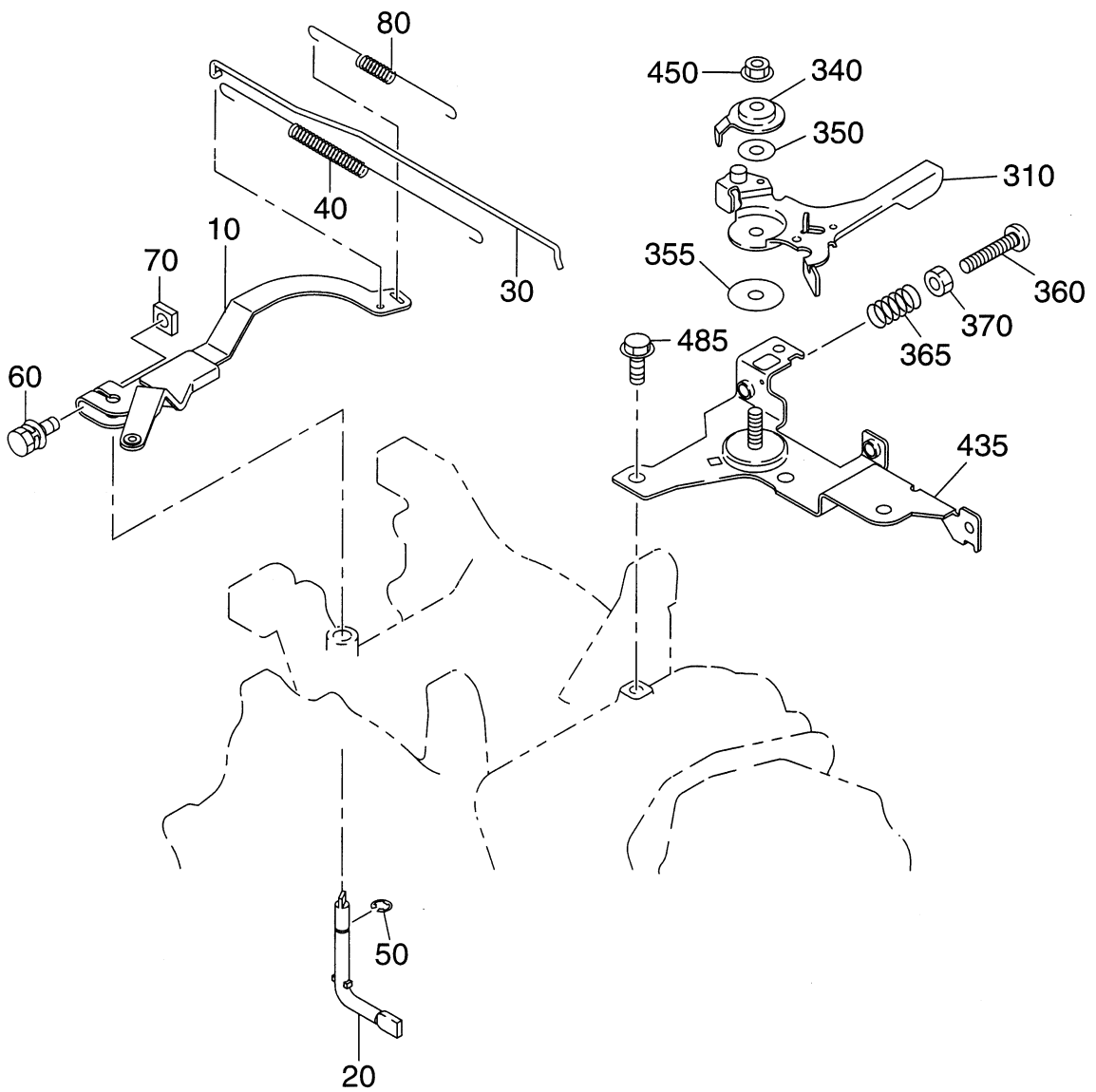



FIG. 500

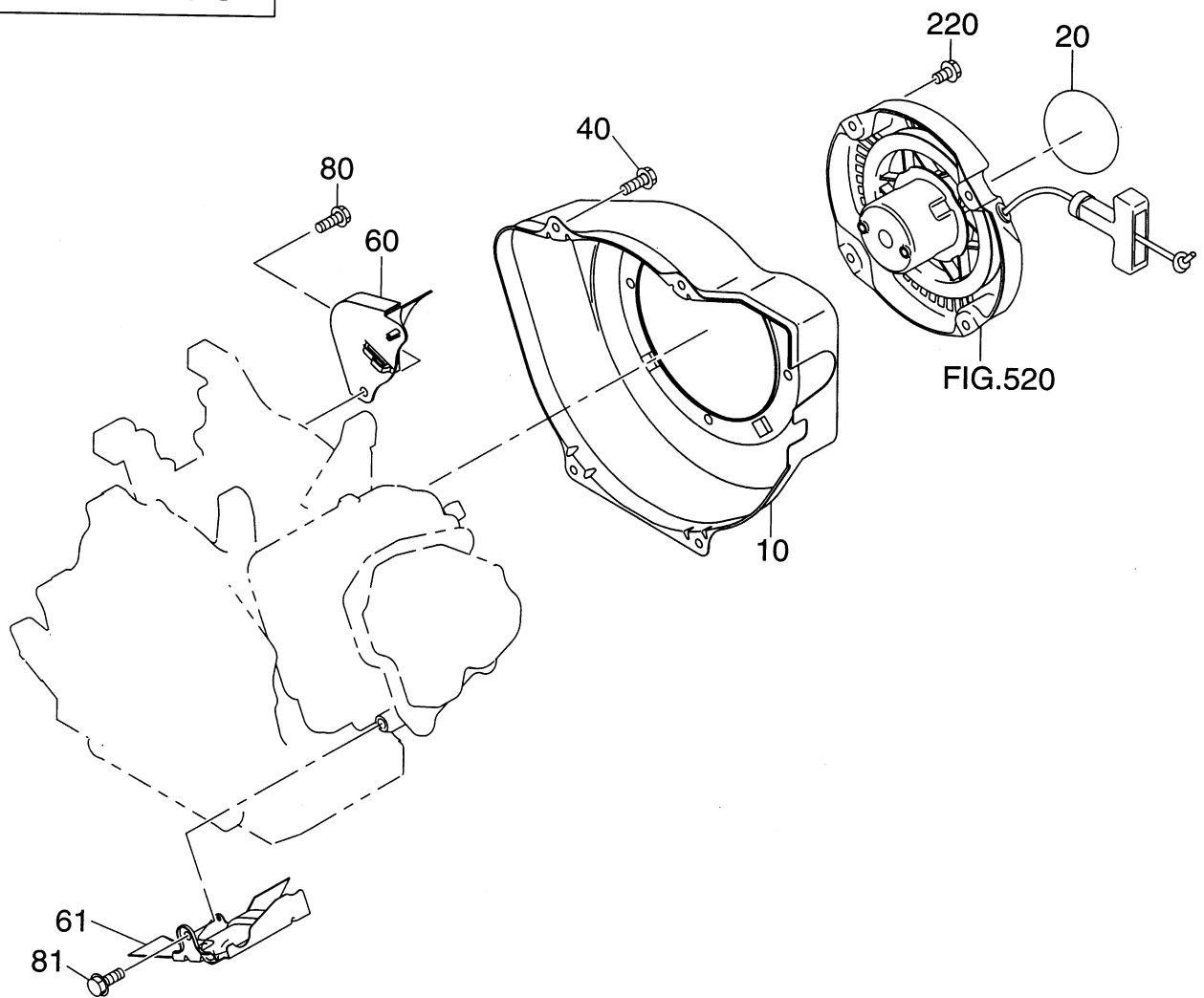

FIG. 520

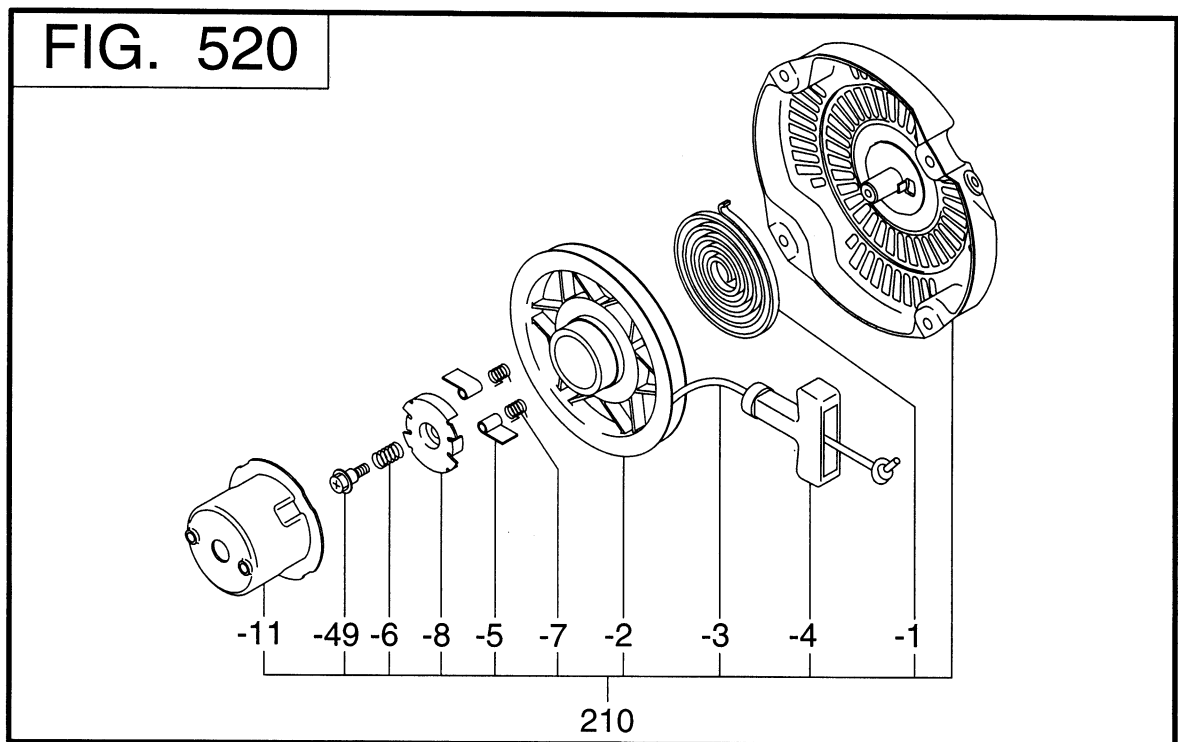



FIG. 600

FIG. 640

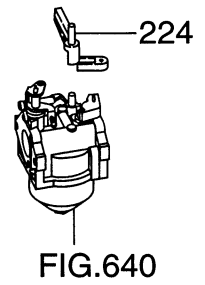
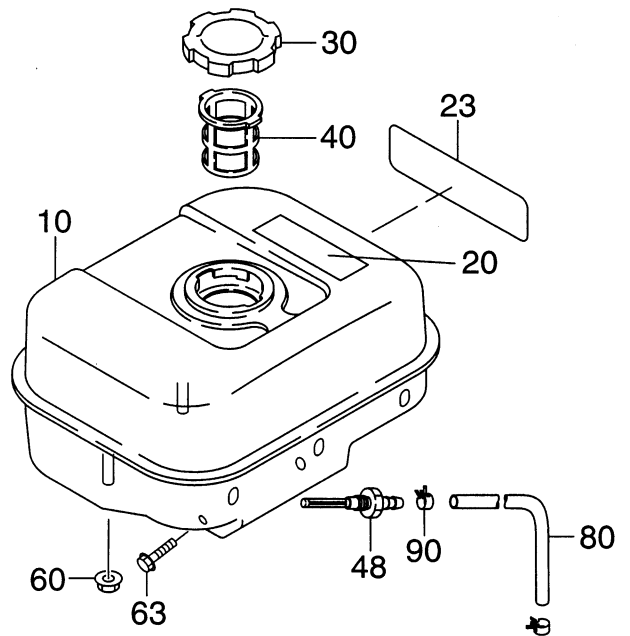
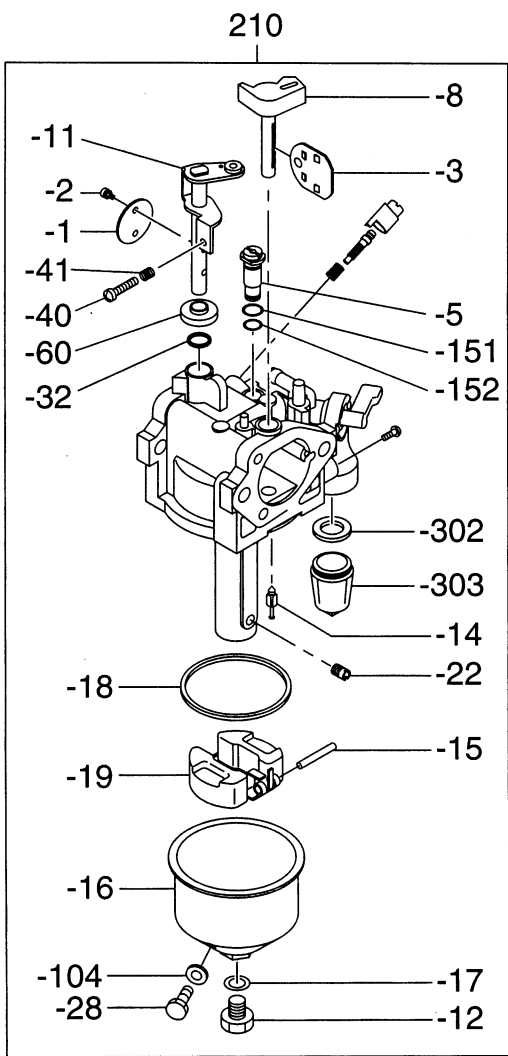

FIG.640

## 6 FUEL LUBRICANT

REF.	PART NUMBER	PART NAME	QTY	REMARKS	CODE NO. FROM-TO	INTERCHANGEABLE PART NUMBER	UNIT PRICE	FIG.
10	279-60101-11	FUEL TANK CP	1	6.1L NEW R YELLOW	-			600
20	073-20051-80	LABEL(WARNING)	1	42X104 ENGLISH	-			600
23	279-95101-03	LABEL(MODEL)	1	32X125	-			600
30	043-04400-50	FUEL TANK CAP CP	1	43DX68DX14H BLACK	-			600
40	064-13600-10	FUEL FILTER	1	36DX46DX43H	-			600
48	050-51200-20	UNION	1	M12X4DX78L W/FILTER	-			600
60	002-38080-00	FLANGE NUT	2		-			600
63	011-00802-50	FLANGE BOLT	2	M8X1.25X16DX25L	-			600
80	085-10600-00	RUBBER PIPE	1	6DX12D	-			600
90	056-11000-30	HOSE CLAMP	2	10DX8BX1T	-			600
210	279-62302-10	CARBURETOR AY	1		-			640
- 1	279-62535-08	VALVE THROTTLE	1		-			640
- 2	251-62450-08	SCREW	2		-			640
- 3	279-62525-08	VALVE CHOKE	1		-			640
- 5	279-62420-08	JET SLOW	1		-			640
- 8	279-62520-08	SHAFT CHOKE	1		-			640
- 11	279-62530-08	SHAFT SUB ASSY(TH)	1		-			640
- 12	251-62453-08	SCREW	1		-			640
- 14	279-62500-08	VALVE ASSY NEEDLE	1		-			640
- 15	279-62515-08	PIN FLOAT LEVER	1		-			640
- 16	279-62550-08	CHAMBER FLOAT	1		-			640
- 17	251-62350-08	GASKET	1		-			640
- 18	279-62540-08	GASKET CHAMBER	1		-			640
- 19	279-62505-08	FLOAT SUB ASSY	1		-			640
- 22	279-62401-08	JET MAIN	1		-			640
- 28	279-62355-08	SCREW DRAIN	1		-			640
- 32	279-62561-08	BUSH	1		-			640
- 40	279-62353-08	SCREW ADJUSTING	1		-			640
- 41	279-62445-08	SPRING	1		-			640
- 60	279-62562-08	COLLAR	1		-			640
-104	279-62552-08	GASKET	1		-			640
-151	279-62452-08	O-RING	1		-			640
-152	279-62451-08	O-RING	1		-			640
-302	064-20064-10	PACKING	1		-			640
-303	064-20078-10	CUP	1		-			640
224	277-43801-01	CHOKE LEVER CP	1		-			600

FIG. 700

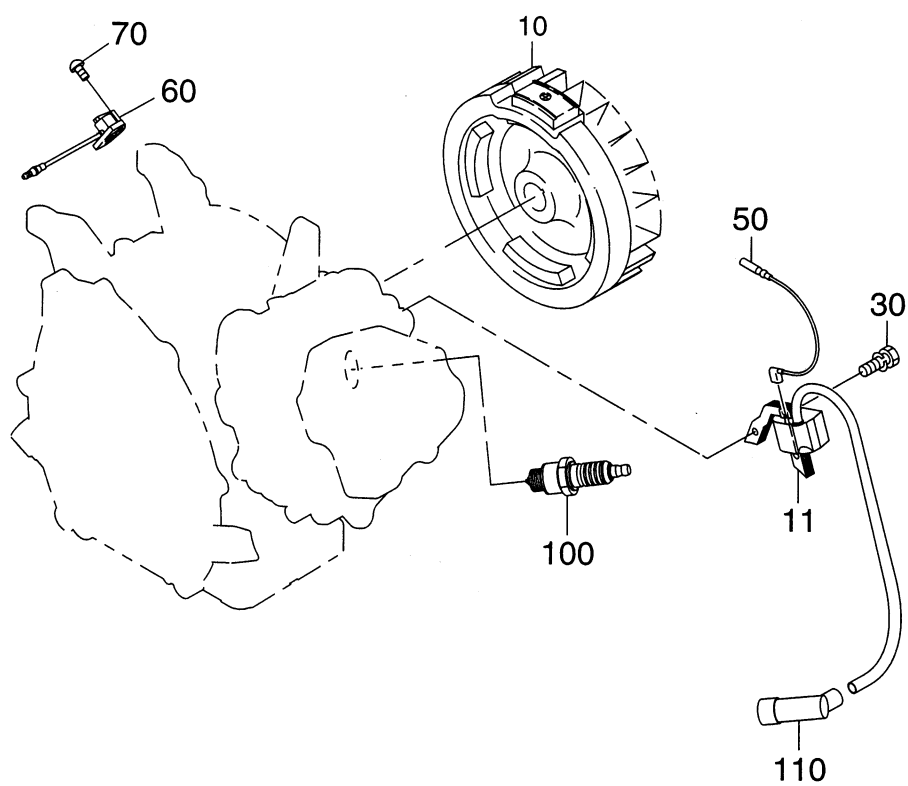



FIG. 770

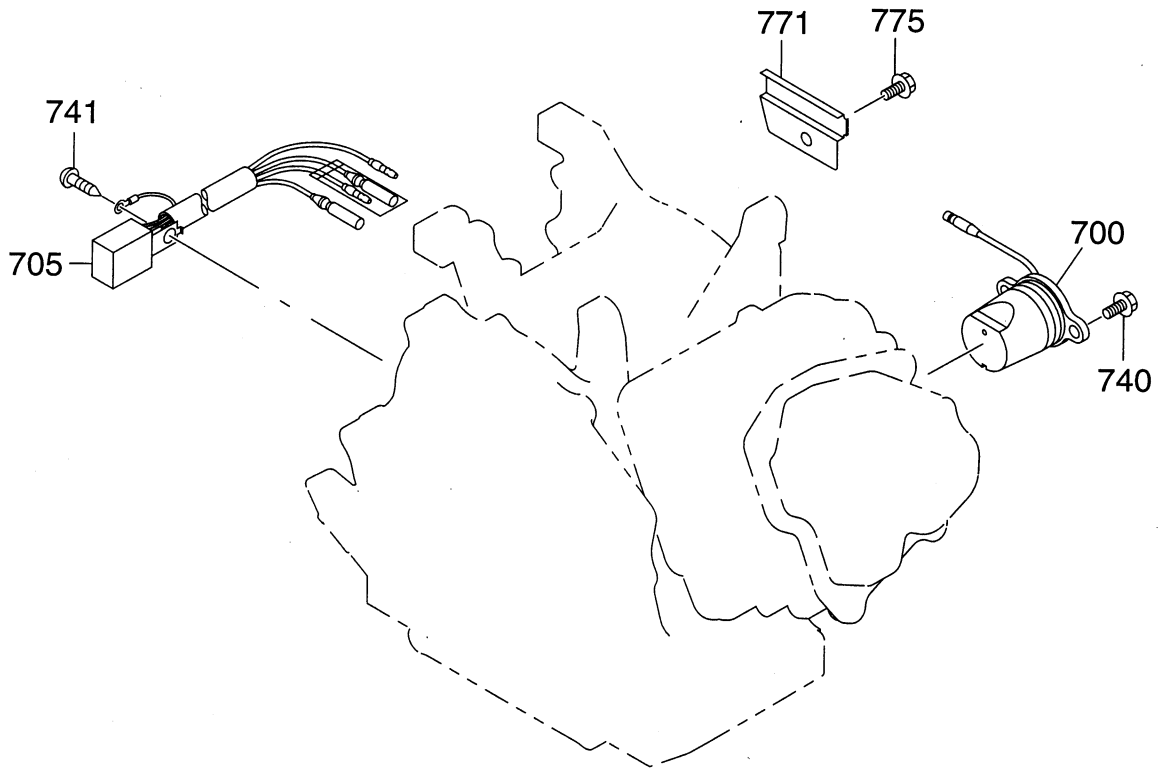



FIG. 900

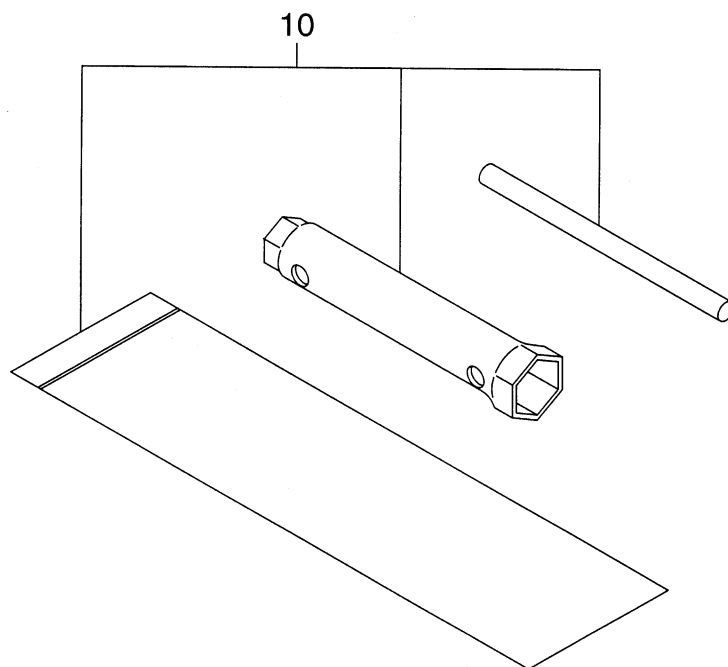
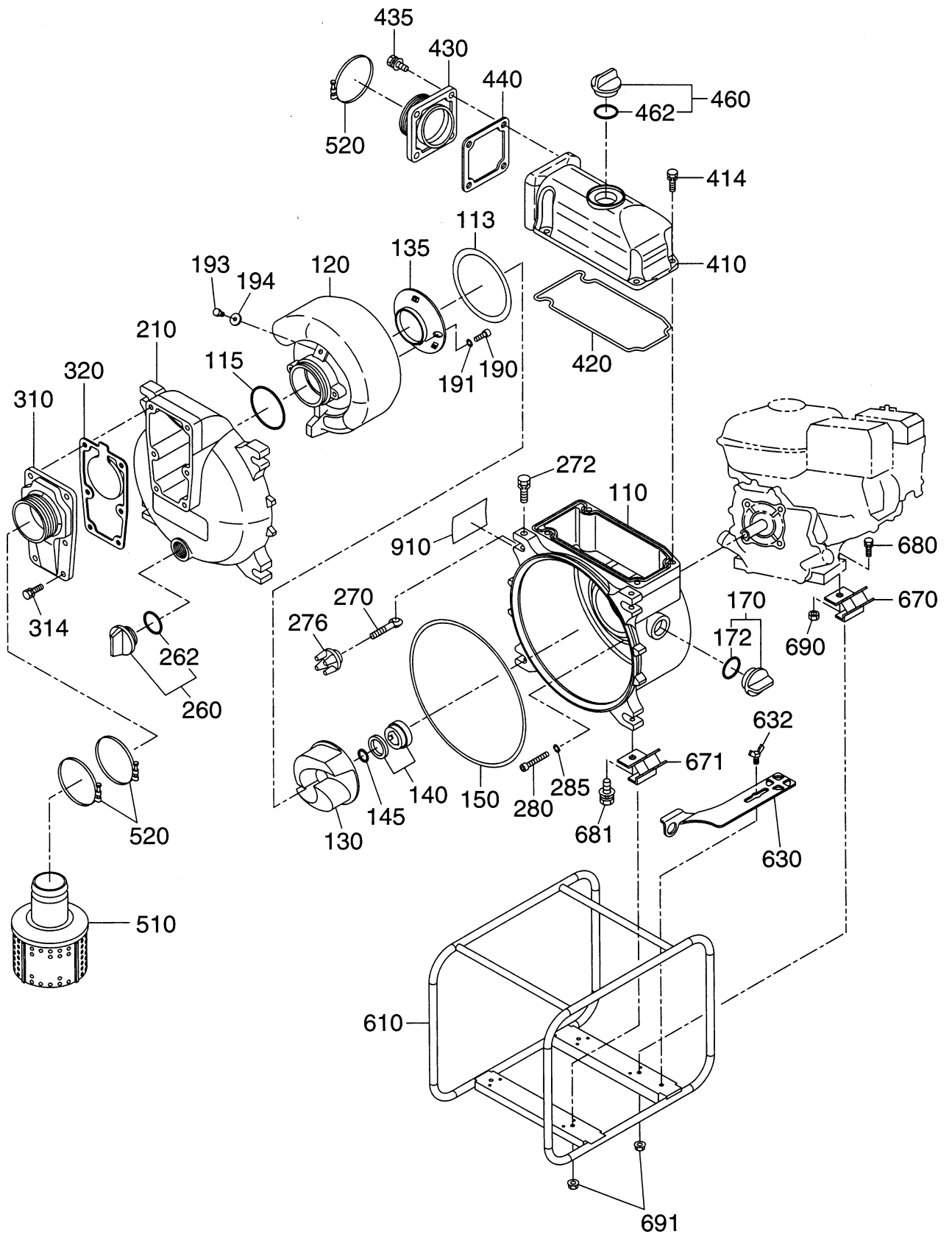



FIG. 4200



## 4 2 PUMP

REF.	PART NUMBER	PART NAME	QTY	REMARKS	CODE NO. FROM-TO	INTERCHANGEABLE PART NUMBER	UNIT PRICE	FIG.
110	470-01154-46	CASING	1		-			4200
113	470-01155-78	CASING PACKING	1		-			4200
115	470-01156-76	O RING	1		-			4200
120	470-01161-64	INNER CASING	1		-			4200
130	470-01155-58	IMPELLER	1		-			4200
135	470-01160-86	WEAR PLATE	1		-			4200
140	470-01156-78	MECHANICAL SEAL	1		-			4200
145	470-01100-81	ADJUSTING WASHER	3		-			4200
150	470-01155-79	FRONT COVER PACKING	1		-			4200
170	470-01180-79	PLUG AY	1		-			4200
172	471-00000-09	O RING	1		-			4200
190	471-00000-74	SOCKET BOLT	2	M8X25L	-			4200
191	471-00000-02	SEAL WASHER	2	8D	-			4200
193	471-00000-75	BOLT & WASHER AY	3	M6X16L	-			4200
194	470-01161-73	WASHER	3	6.5DX22D	-			4200
210	470-01158-82	FRONT COVER	1		-			4200
260	470-01180-78	PLUG AY	1		-			4200
262	471-00000-09	O RING	1		-			4200
270	470-01155-80	COVER BOLT	4		-			4200
272	471-00000-73	BOLT & WASHER AY	4	M12X45L	-			4200
276	470-01155-90	KNOB	4		-			4200
280	470-01165-17	SOCKET BOLT	4	M8X60L	-			4200
285	470-01164-93	WASHER	4	8D	-			4200
310	470-01113-60	SUCTION FRANGE	1		-			4200
314	471-00000-50	BOLT & WASHER AY	6	M10X25L	-			4200
320	470-01156-92	CHECK VALVE	1		-			4200
410	470-01155-47	DELIVERY BODY	1		-			4200
414	471-00000-34	BOLT & WASHER AY	4	M10X30L	-			4200
420	470-01155-48	HEAD PACKING	1		-			4200
430	470-01158-37	DELIVERY FLANGE	1		-			4200
435	471-00000-34	BOLT & WASHER AY	4	M10X30L	-			4200
440	470-01105-84	PACKING, DELIVERY	1		-			4200
460	470-01184-50	PLUG AY	1		-			4200
462	471-00000-20	O RING	1		-			4200
510	470-01109-78	STRAINER	1		-			4200
520	471-00000-39	HOSE BAND	3		-			4200



 **FUJI HEAVY INDUSTRIES LTD.**

**INDUSTRIAL PRODUCTS COMPANY**

4-410 Asahi, Kitamoto-shi,  
Saitama, 364-8511, Japan

Phone +81(48) 593-7896

Fax +81(48) 593-7965

Web site <http://www.fhi.co.jp/robin/>