



PARTS CATALOG

Robin

Pump

Model

PKX301

**Spec. No. PKX30100370
(EX170D10060)**

 **FUJI HEAVY INDUSTRIES LTD.**
INDUSTRIAL PRODUCTS COMPANY

ISSUE EMD - PP5873
ISSUE DATE 2003.3

HOW TO USE THIS PARTS CATALOG

REF.	PART NUMBER	PART NAME	QTY	REMARKS	CODE NO. FROM-TO	INTERCHANGEABLE PART NUMBER	UNIT PRICE	FIG.
10	281-60101-01	FUEL TANK CP	1	2.8L NEW R YELLOW	-			600
20	073-20044-50	LABEL(CAUTION)	1	38X70	-			600
30	043-04300-15	FUEL TANK CAP CP	1	43DX68DX14H	5296-			600
	043-04301-00	FUEL TANK CAP CP	1		-5295			600
40	064-13600-10	FUEL FILTER	1	36DX46DX43H	-			600
50	064-20064-00	FUEL STRAINER AY	1		-			630
- 1	064-20064-20	FILTER	1		-			630
- 2	064-20064-10	PACKING	1		-			630
- 3	064-20042-10	CUP, STRAINER	1		-			630

- ① **SECTION NAME** Parts are broadly classified according to their functions. Refer to section indexes(contents)for respective section name.
- ② **FIG.No**..... It indicates illustration number. FIG.No. with the same figure in the third of hundreds shows that it is in a group of the same section. FIG.No. illustrating the target part can be read in the right-end section of the list.
- ③④ **REF.No.** It is a number to compare the part illustrated with the part number in the list. Serch for REF.No. in the list in the corresponding REF.No. in the illustration to determine the part number.
Section ④ shows a 'SUB-ASSEMBLY PART' of section ③ which is indicated by the number led by '-' such as '-1','-2'.
- ⑤ **PART NUMBER** It is the number assigned for sales unit.
Use the PART No. when marking an order.
- ⑥ **PART NAME**..... It is designation of the part.
- ⑦ **Q'ty** Quantity of part being employed for each product.
- ⑧ **REMARKS** This gives a distinctive feature and/or a supplementary comment for the type,the specification, and the part concerned.
- ⑨ **INTERCHANGEABLE...** It shows part number(s) interchangeable for the part given in the section
PART NUMBER ⑤.
- ⑩ **CODE No.** It indicates history of progress in which improved parts have been introduced in the product.The CODE No. helps to identify PART No. being employed in the product concerned.

—	The part has been employed in the product irrespective of CODE No.
5296—	The part is employed in the products with CODE No. of 5296 and after this number.
—5295	The part is employed in the products with CODE No. of 5295 and before this number.

FIG. 100

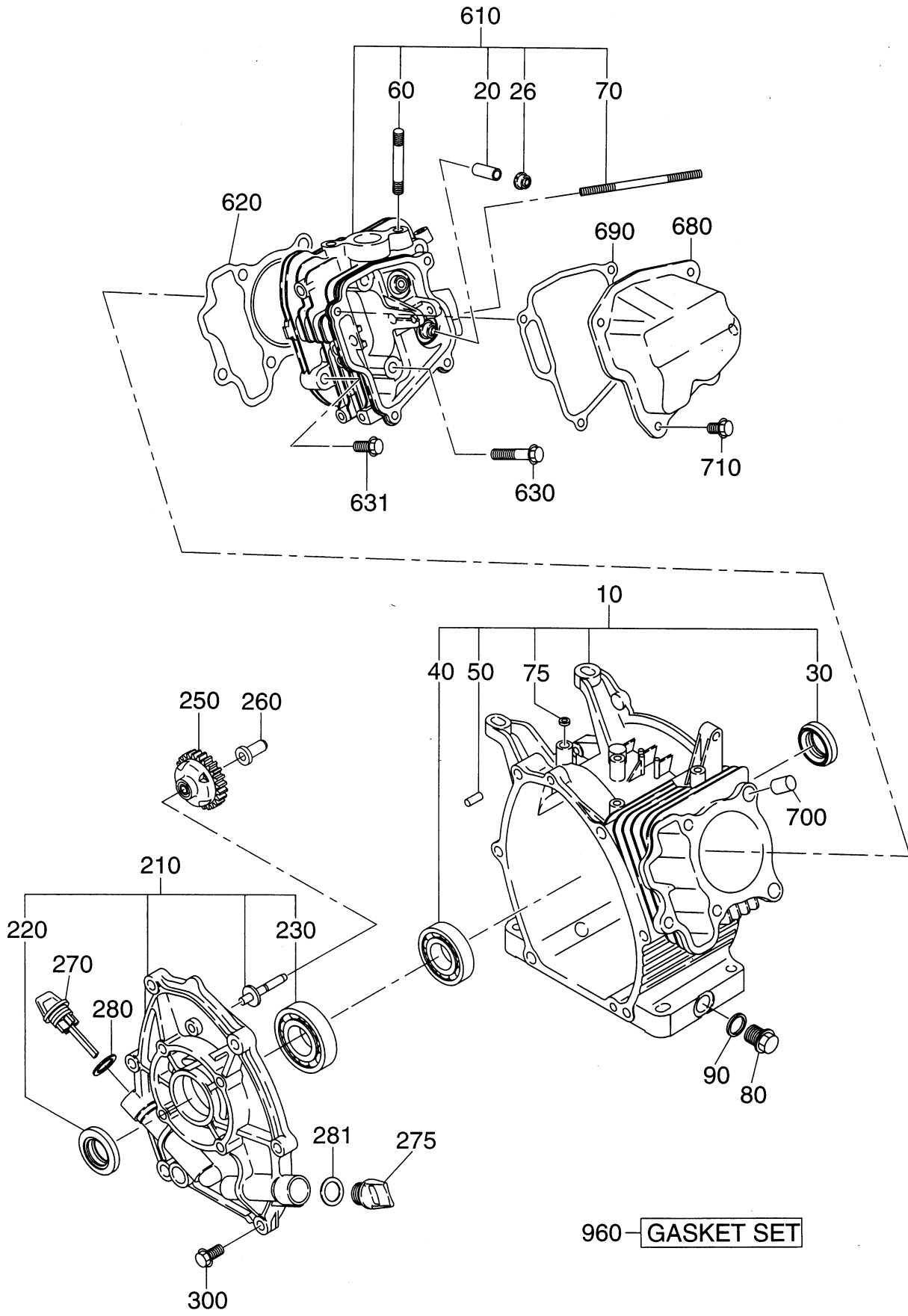

FIG. 200

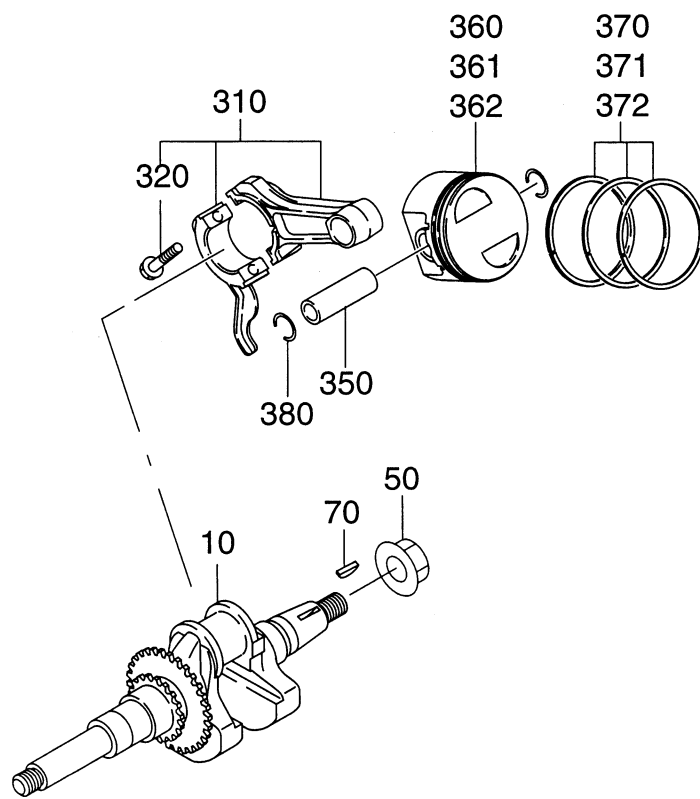
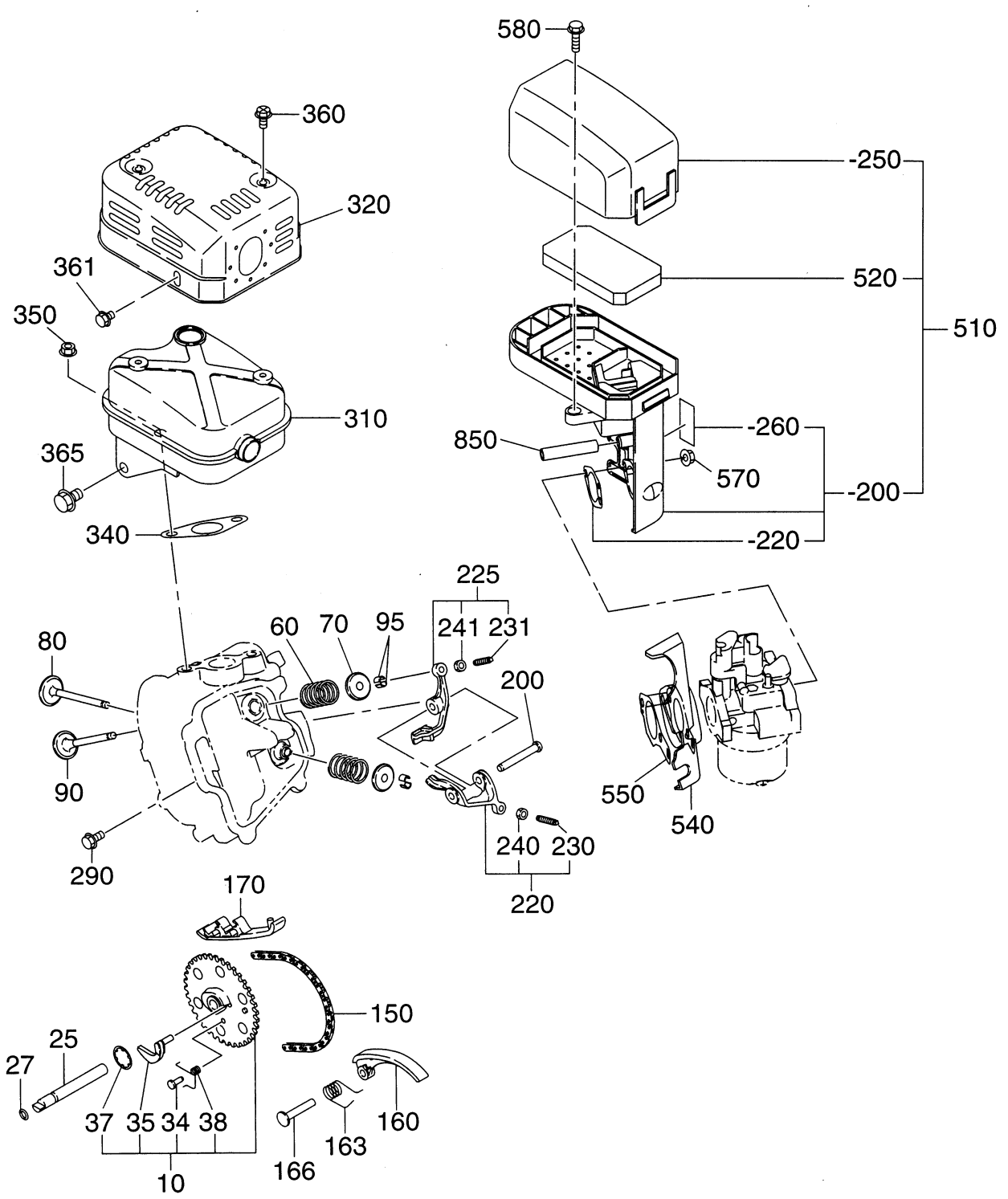

FIG. 300



3 INTAKE EXHAUST

REF.	PART NUMBER	PART NAME	QTY	REMARKS	CODE NO. FROM-TO	INTERCHANGEABLE PART NUMBER	UNIT PRICE	FIG.
10	277-31601-01	CAM SHAFT CP	1	85DX2. 9B N=40	-			300
25	277-35101-03	PIN(CAM SHAFT)	1	9DX78. 5L	-			300
27	024-00600-10	O RING	1	5. 8DX9. 6D	-			300
34	277-38601-03	PIN(SPRING)	1	4DX8DX9L	-			300
35	277-36401-03	RELEASE LEVER	1		-			300
37	277-36501-03	CLIP	1	13. 8DX20. 3DX0. 4T	-			300
38	277-38701-03	RETURN SPRING	1		-			300
60	279-33601-03	VALVE SPRING	2		-			300
70	269-33701-03	SPRING RETAINER	2		-			300
80	277-33401-13	INTAKE VALVE	1	25. 5DX5. 5DX68. 1L	-			300
90	277-33501-13	EXHAUST VALVE	1	23. 5DX5. 5DX68. 1L	-			300
95	132-10KA0-31	COLLET-VALVE	4		-			300
150	277-35601-01	TIMING CHAIN CP	1	88 LINK	-			300
160	277-36911-03	TENTIONER	1		-			300
163	277-37101-03	SPRING(TENTIONER)	1		-			300
166	277-36902-03	PIN(TENTIONER)	1	6DX13DX34L	-			300
170	277-36913-13	CHAIN GUIDE	1		-			300
200	277-35001-23	PIN(ROCKER)	1	6DX9DX41L	5692-			300
	277-35001-13	PIN(ROCKER)	1	6DX9DX41L	-5691	277-35001-23		300
220	277-36101-00	ROCKER ARM(IN) AY	1		-			300
225	277-36102-00	ROCKER ARM(EX) AY	1		-			300
230	014-90500-10	ADJUST SCREW	1	M5X0. 5X23L	-			300
231	014-90500-10	ADJUST SCREW	1	M5X0. 5X23L	-			300
240	017-00500-20	NUT	1	M5X0. 5X4. 1H	-			300
241	017-00500-20	NUT	1	M5X0. 5X4. 1H	-			300
290	011-00600-20	FLANGE BOLT	1	M6X1. 0X14DX12L	-			300
310	277-30101-11	MUFFLER CP	1		-			300
320	277-34201-11	MUFFLER COVER CP	1		5753-			300
	277-34201-01	MUFFLER COVER CP	1		-5752	277-34201-11		300
340	277-35201-03	GASKET(MUFFLER)	1	T=0. 2 26D 9DX58P	-			300
350	980-20082-80	FLANGE NUT	2		-			300
360	015-20600-90	TAPPING BOLT	2	M6X13DX10L	-			300
361	011-00600-10	FLANGE BOLT	1	M6X1. 0X14DX8L	-			300
365	011-00801-50	FLANGE BOLT	1	M8X1. 25X16DX12L	-			300
510	277-32611-00	AIR CLEANER AY	1		-			300
-200	277-32601-08	BASE CP	1		-			300

FIG. 400

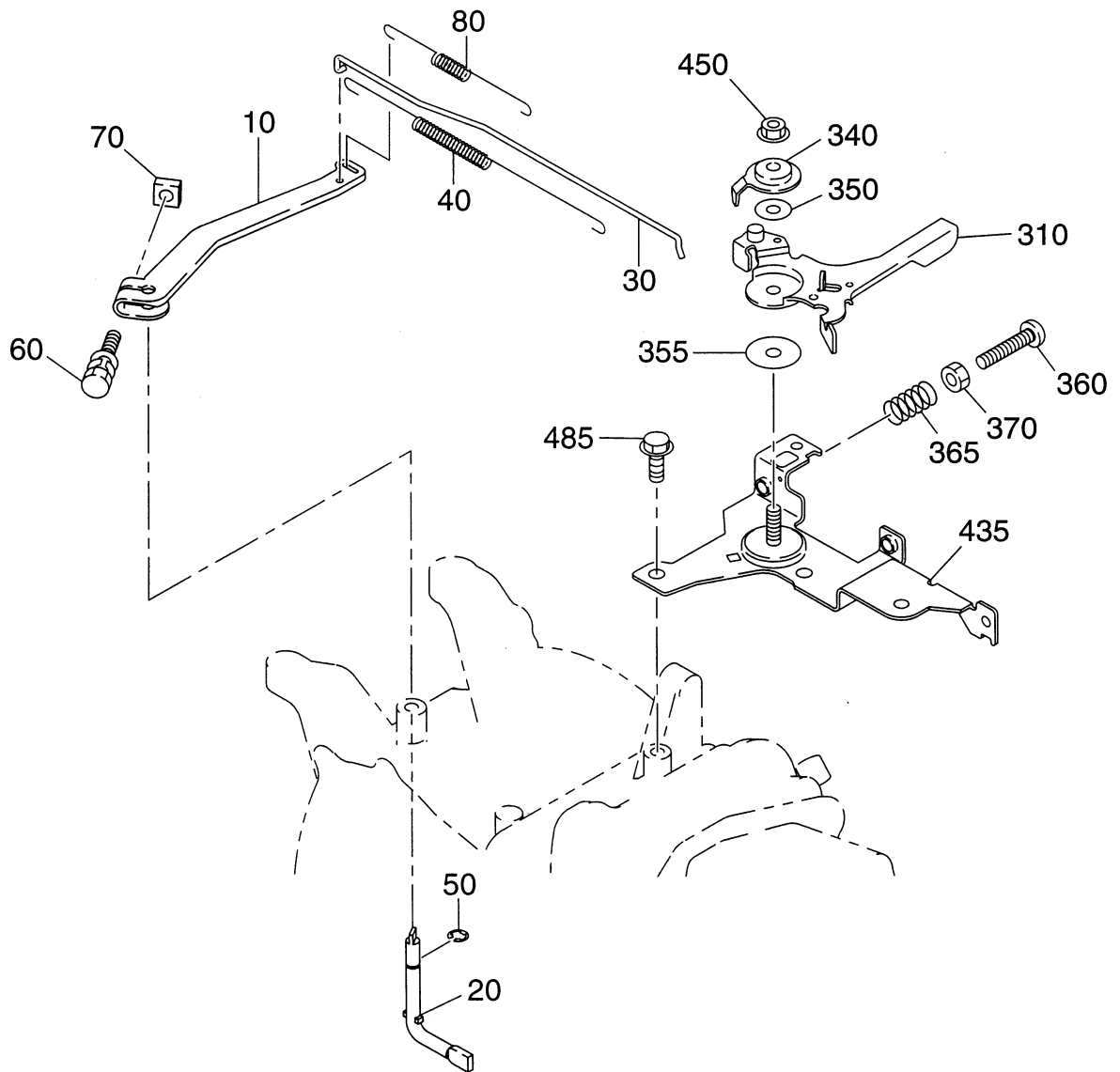

FIG. 500

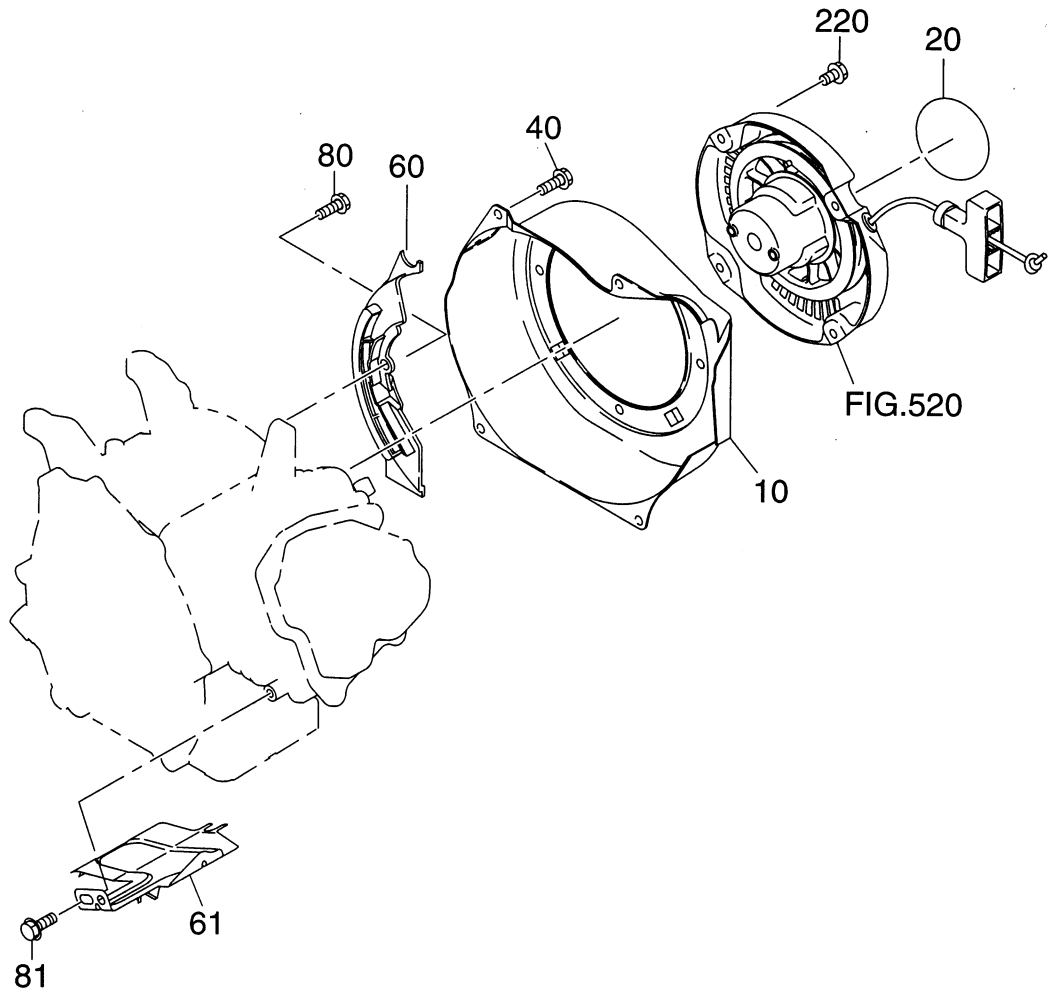

FIG. 520

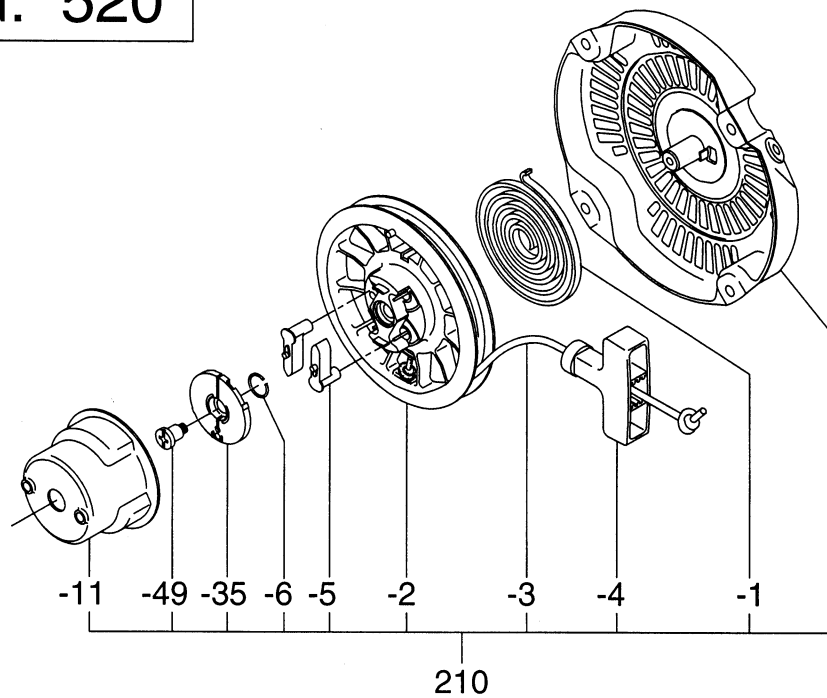

FIG. 600

FIG. 640

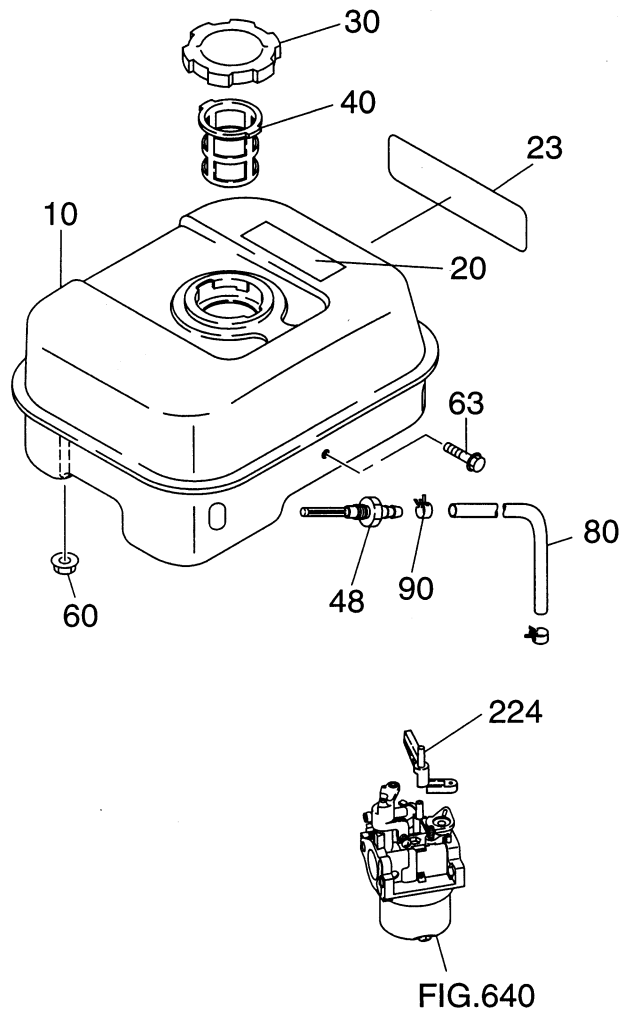
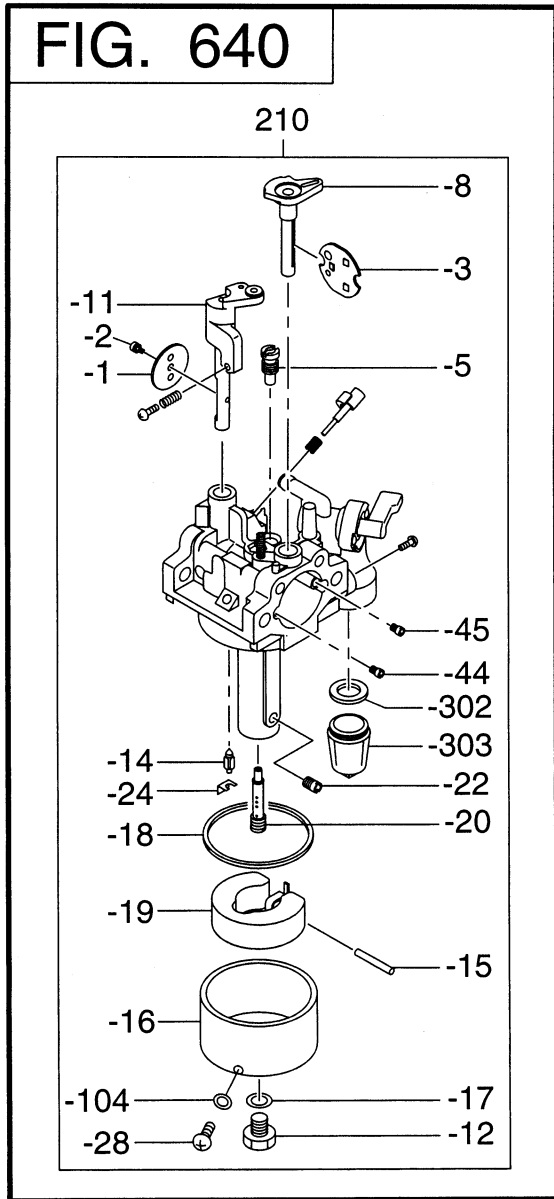

FIG. 700

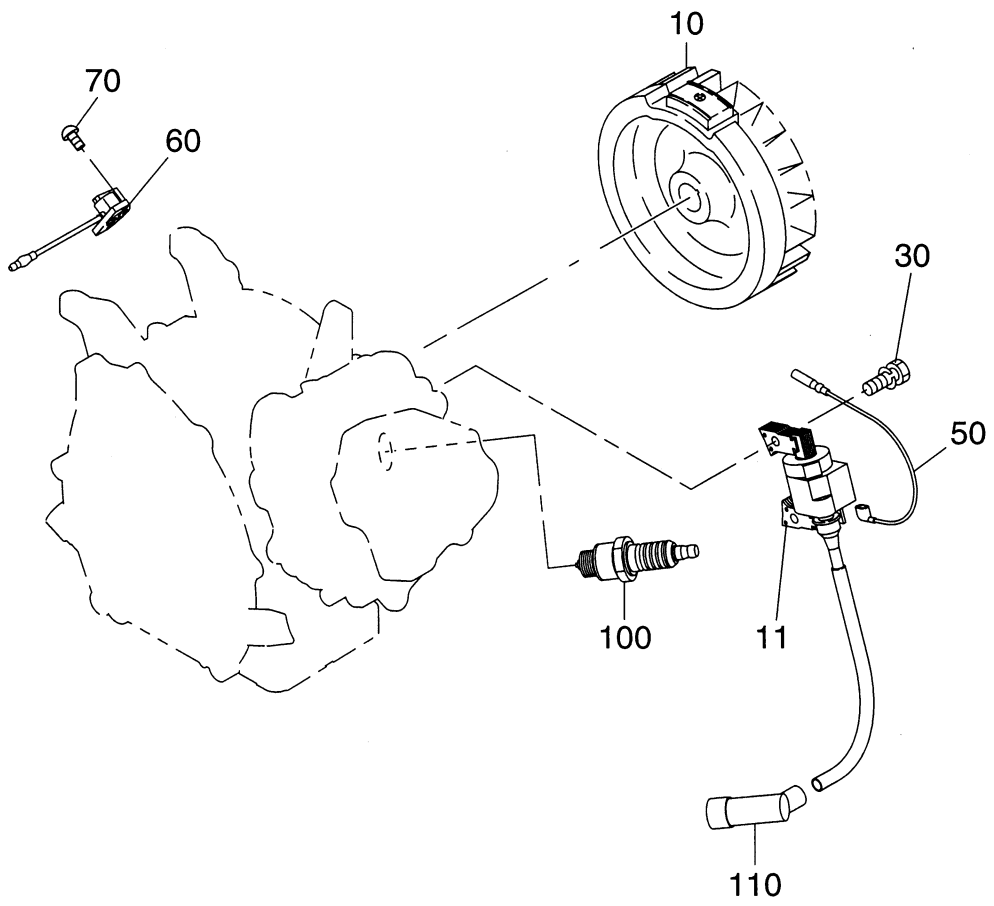

FIG. 770

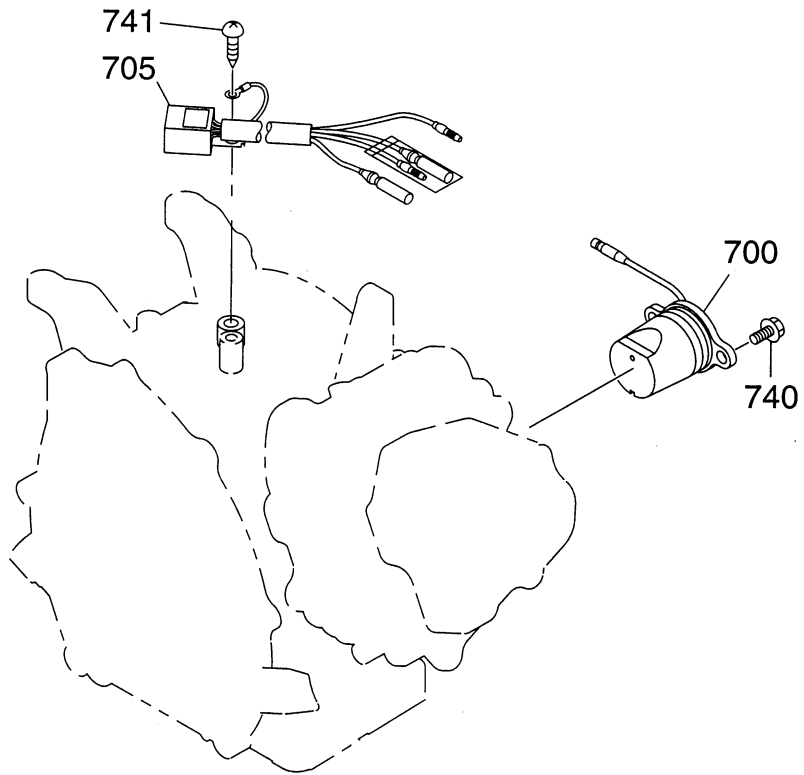

FIG. 900

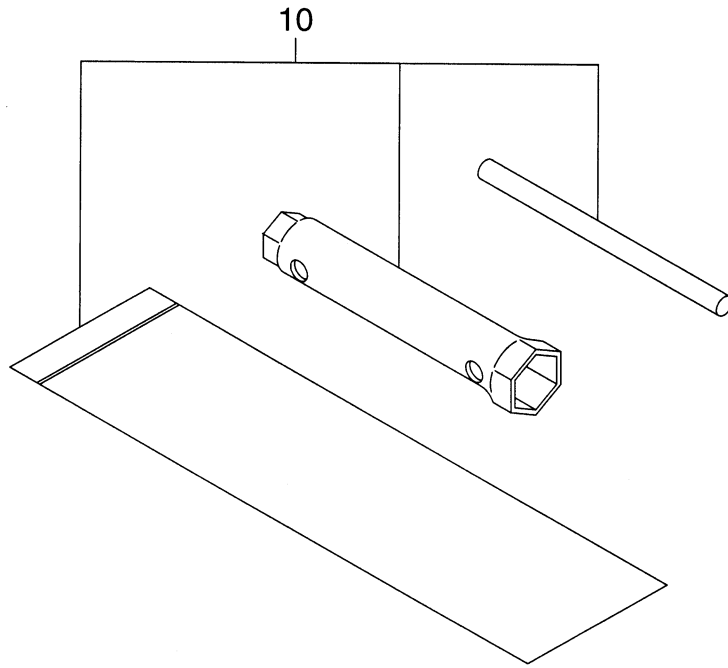
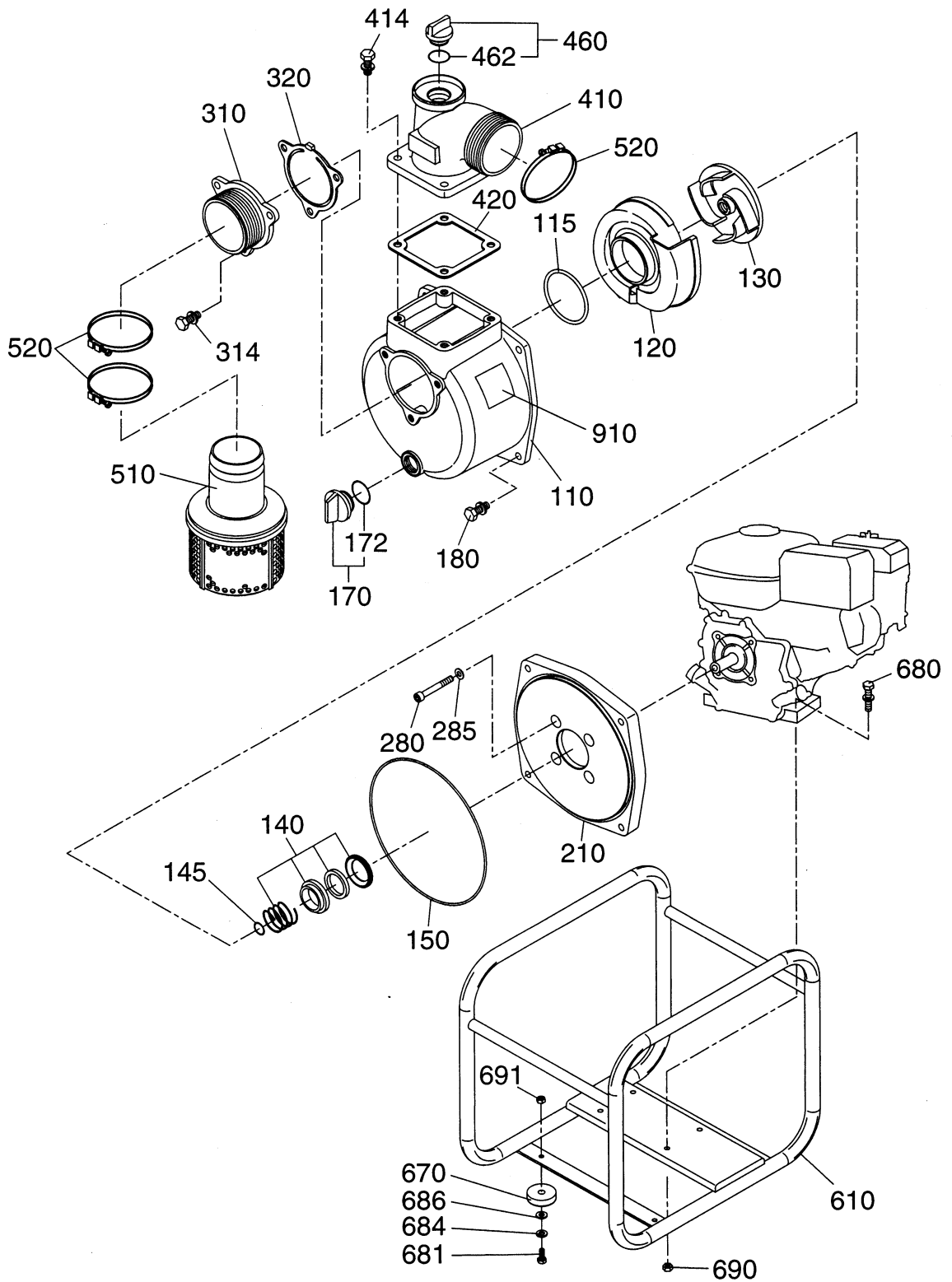

FIG. 4200



 **FUJI HEAVY INDUSTRIES LTD.**

INDUSTRIAL PRODUCTS COMPANY

4-410 Asahi, Kitamoto-shi,
Saitama, 364-8511, Japan

Phone +81(48) 593-7896

Fax +81(48) 593-7965

Web site <http://www.fhi.co.jp/robin/>