



PARTS CATALOG

Robin

Pump

Model

PTX201H

Spec. No. PTX201H0000
(EX170D10120)
PTX201H0010
(EX170D10130)

FUJI HEAVY INDUSTRIES LTD.
INDUSTRIAL PRODUCTS COMPANY

ISSUE EMD - PP6178
ISSUE DATE 2005.5

HOW TO USE THIS PARTS CATALOG

REF. NO.	PART NUMBER		PART NAME		CODE NO.	QTY	REMARKS	INTERCHANGEABLE PART NUMBER	FIG. NO.
				SPEC. NO.	FROM - TO				
10	276-60101-01		FUEL TANK CP		-	1	2.7L ROBIN YELLOW	276-60101-11	600
20	073-20044-50		LABEL (CAUTION)		-	1	38X70 ILLUSTR		600
	073-20051-81		EX130D10120		-	1	42X104 ENGLISH		600
30	043-04300-15		FUEL TANK CAP		-	1			600
40	X64-13600-10		FUEL FILTER		4415 -	1	36DX46DX43H		600
	064-13600-10		FUEL FILTER		- 4414	1	36DX46DX43H		600
50	064-20064-00		FUEL STRAINER		-	1			630
- 1	064-20064-20		FILTER		-	1			630
- 2	064-20064-10		PACKING		-	1			630
- 3	064-20042-10		CUP		-	1			630

- ① **SECTION NAME**..... Parts are broadly classified according to their functions. Refer to section indexes(contents)for respective section name.
- ② **FIG.No.**..... It indicates illustration number. FIG.No. with the same figure in the third of hundreds shows that it is in a group of the same section. FIG.No. illustrating the target part can be read in the right-end section of the list.
- ③④ **REF.No.**..... It is a number to compare the part illustrated with the part number in the list. Search for REF.No. in the list in the corresponding REF.No. in the illustration to determine the part number.
Section ④ shows a 'SUB-ASSEMBLY PART' of section ③ which is indicated by the number led by '-' such as '-1', '-2'.
- ⑤ **PART NUMBER**..... It is the number assigned for sales unit.
Use the PART No. when marking an order.
PART No. employed in the representative SPEC. No. has been entered at the head of each REF. No. being shifted to the left.
However, the parts with marking of "*****" show that they are not used in the representative SPEC. No..
PART No. entered to the right side as in ⑤A are the parts employed in a SPEC. No. other than the representative SPEC. No., and each SPEC. No. using these parts are listed in the section on the right as in ⑦ in ascending order. If no entry of SPEC. No. contains, it is the same PART No. as the representative SPEC. No. (STD) or the part which has not been employed in the SPEC. No. concerned.

⑥ **PART NAME** It is designation of the part. The SPEC. No. corresponding to the PART No. are listed below the part name. PART NAME of PART No. is indicated on the same line as each REF. No..

⑦ **SPEC.No.**..... This helps identify specifications of the product. This manual has been edited based on RAS17031000 · EH092DN8510 as representative SPEC. No.. For the SPEC. No other than the representative SPEC. No., it has been edited so that parts different from the representative SPEC. No. are to be listed.

⑧ **CODE No.**..... It indicates history of progress in which improved parts have been introduced into the product concerned.The CODE No. helps identify PART No. being employed in the product concerned.

—
4415—
—4414

The part has been employed in the product irrespective of CODE No.

The part is employed in the products with CODE No. of 4415 and after this number.

The part is employed in the products with CODE No. of 4414 and before this number.

⑨ **Q'ty** Quantity of part being employed for each product. (If quantity of the same PART No. employed varies according to SPEC. No., the maximum quantity is indicated.)

⑩ **REMARKS** This gives a distinctive feature and/or a supplementary comment for the type, the specification, and the part concerned.

⑪ **INTERCHANGEABLE** .. It shows part number(s) interchangeable for the part given in the section **PART NUMBER** ⑤ (5A) . Please note that parts with interchangeable PART No. may be delivered for your order.

Table of abbreviations/略語一覽

ABBREVIATIONS/略語	DESCRIPTION	説明
A	AMPERE	アンペア
AC	AIR CLEANER	エアクリーナ
AY	ASSEMBLY	アッセンブリ
B	BREADTH	幅
BB	BALL BEARING	ボールベアリング
CD	CENTER DISTANCE	中心間距離
CP	COMPLETE	コンプリート
D	DIAMETER	内径、外径、中心径
EX	EXPORT	輸出
EX	EXHAUST	排気
FIG	FIGURE	フィギュア(図解)
FR	FRONT	前側
H	HEIGHT	高さ
HZ	HERTZ	ヘルツ
IN	INCH	インチ
IN	INTAKE	吸入
L	LITER	リットル
L	LENGTH	長さ
LH	LEFT HAND	左側
MG	MAGNETIC	マグネチック
N	NUMBER	数、巻数
N R Y	NEW ROBIN YELLOW	新ロビン色
OS	OIL SENSOR	オイルセンサ
O.S.	OVER SIZE	オーバーサイズ
P	PITCH	ピッチ
PD	PITCH DIAMETER	中心径
PTO	POWER TAKE OFF	動力取出し
REF	REFERENCE	レファレンス(照合)
RH	RIGHT HAND	右側
RR	REAR	後側
ST	STARTER	スタータ
STD	STANDARD	標準
SW	SPRING WASHER	スプリングワッシャ
SW	SWITCH	スイッチ
T	THICKNESS	厚さ
TH	THROTTLE	スロットル
UN	UNIT	ユニット
U.S.	UNDER SIZE	アンダーサイズ
V	VOLTAGE	ボルト
W	WASHER	ワッシャ
W	WATT	ワット
W	WIDTH	幅
W/	WITH	付き
W/O	WITHOUT	無し

CONTENTS

ENGINE PARTS

	FIG.
1 CRANKCASE	100
2 CRANKSHAFT, PISTON	200
3 INTAKE, EXHAUST	300,315
4 GOVERNOR, OPERATION	400
5 COOLING, STARTING	500,520
6 FUEL LUBRICANT	600,640
7 ELECTRIC DEVICE	700,770
9 ACCESSORIES	900

PUMP PARTS

42 PUMP	4200
---------	------

FIG. 100

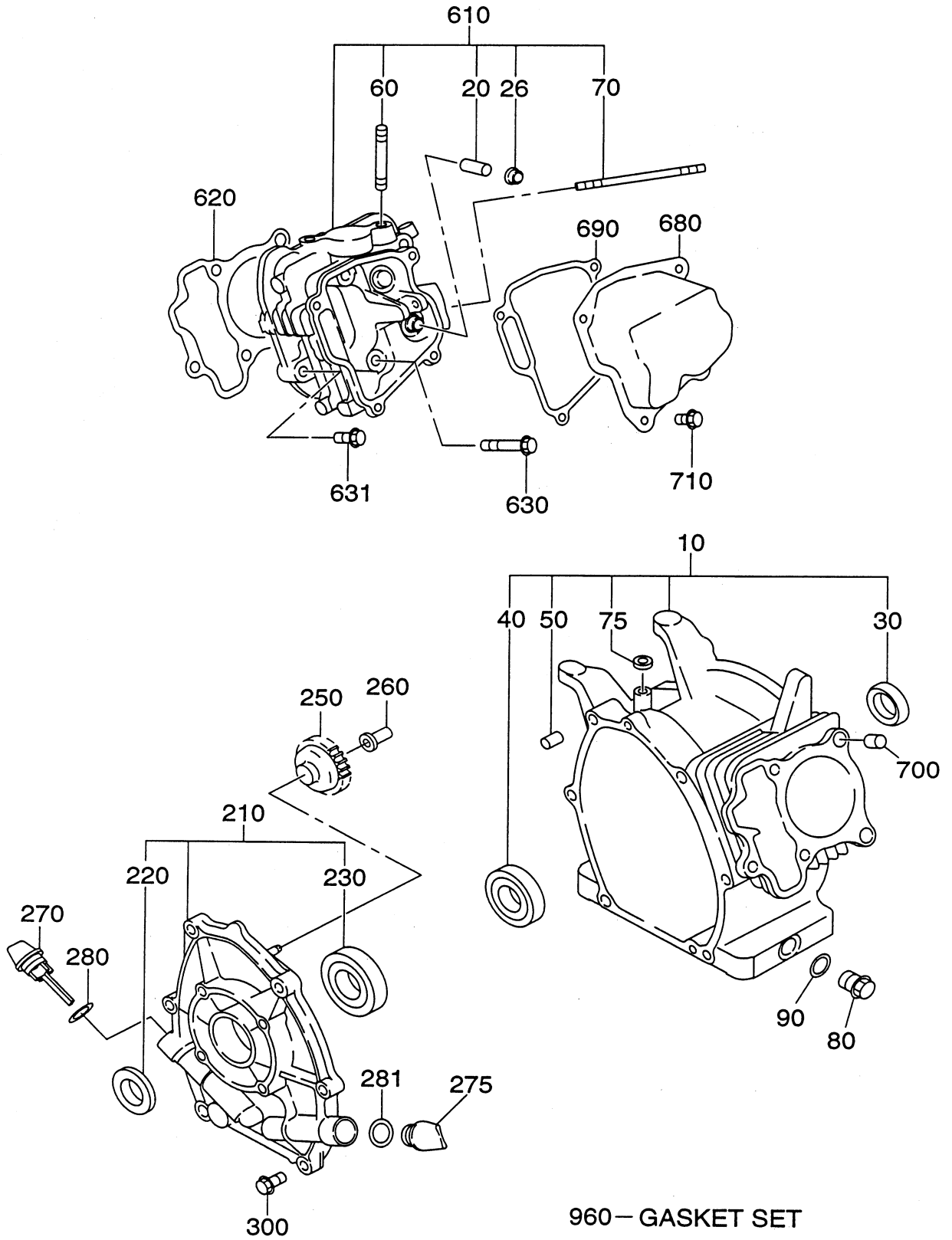

1 CRANK CASE

REF. NO.	PART NUMBER		PART NAME		CODE NO. FROM - TO	QTY	REMARKS	INTERCHANGEABLE PART NUMBER	FIG. NO.	
		PART NUMBER		SPEC. NO.						
10	277-10101-41		CRANK CASE CP		-	1			100	
	277-10102-41		EX170D10130		-	1	W/OIL SENSOR		100	
20	237-14202-03		VALVE GUIDE		-	2	5.5DX9.5DX27L		100	
26	277-16010-01		STEM SEAL		-	1	5.5DX9.5DX15DX7.8B		100	
30	044-02502-00		OIL SEAL		-	1	25DX38DX7B		100	
40	060-02800-21		BALL BEARING		-	1	28DX58DX16B		100	
50	277-15011-03		PIPE KNOCK		-	2	10.3DX8.5DX14L		100	
60	010-50802-50		STUD		-	2	M8X1.25X25L		100	
70	010-50603-51		STUD		-	2	M6X1.0X98L		100	
75	044-00600-20		OIL SEAL		-	1	6DX10DX2.5B		100	
80	040-11400-30		PLUG		-	2	M14X1.5X20DX12L		100	
90	021-11400-20		GASKET		-	2	14.1DX19DX2.3T		100	
210	277-11001-31		MAIN BEARING COVER C		-	1	FLANGE 4-M8X1.25		100	
220	044-02502-10		OIL SEAL		-	1	25DX41.25DX6B		100	
230	060-02501-40		BALL BEARING		-	1	25DX52DX15B		100	
250	277-45004-H1		GOVERNOR GEAR CP		-	1	53DX29.1T N=33		100	
260	277-41901-03		GOVERNOR SLEEVE		-	1	6DX7.6DX16DX26L		100	
270	277-63601-13		OIL GAUGE		-	2	M18X1.5 L=70+18		100	
275	277-65001-03		FILLER PLUG		-6209	1			100	
280	021-31600-20		GASKET		-	2	16DX23DX1.2T RUBBER		100	
281	021-31600-20		GASKET		-6209	1	16DX23DX1.2T RUBBER		100	
300	001-04083-50		FLANGE BOLT		-	6			100	
610	277-13001-11		CYLINDER HEAD CP		-	1			100	
620	277-15001-23		GASKET (HEAD)		-	1	T=0.2		100	
630	011-00802-40		FLANGE BOLT		-	4	M8X1.25X16DX68L		100	
631	011-00803-10		FLANGE BOLT		6179-	1	M8X1.25X16DX33L		100	
	001-04083-50		FLANGE BOLT		-6178	1			100	
680	277-15503-01		ROCKER COVER CP		6666-	1			100	
	277-15501-01		ROCKER COVER CP		-6665	1		277-15503-01	100	
690	277-16001-13		GASKET (ROCKER COVER)		6210-	1	T=0.5		100	
	277-16001-03		GASKET (ROCKER COVER)		-6209	1	T=0.7	277-16001-13	100	
700	277-15011-03		PIPE KNOCK		-	2	10.3DX8.5DX14L		100	
710	011-00600-20		FLANGE BOLT		-	4	M6X1.0X14DX12L		100	
960	277-99001-27		GASKET SET		-	1			100	
			DETAILS ARE ON NEXT PAGE							

1 CRANK CASE

REF. NO.	PART NUMBER		PART NAME		CODE NO. FROM - TO	QTY	REMARKS	INTERCHANGEABLE PART NUMBER	FIG. NO.
		PART NUMBER		SPEC. NO.					
277-99001-27						GASKET SET			
	PART NUMBER	PART NAME			Q'ty	FIG.	REF.		
1)	021-11400-20	GASKET			2	100	90		
2)	021-31600-20	GASKET			2	100	280		
3)	277-15001-23	GASKET(HEAD)			1	100	620		
4)	277-16001-13	GASKET (ROCKER COVER)			1	100	690		
5)	277-35201-13	GASKET(MUFFLER)			1	300	340		
6)	277-35903-J3	GASKET 2(INSULATOR)			1	300	550		
7)	277-35902-J3	GASKET 1(INSULATOR)			1	300	560		

FIG. 200

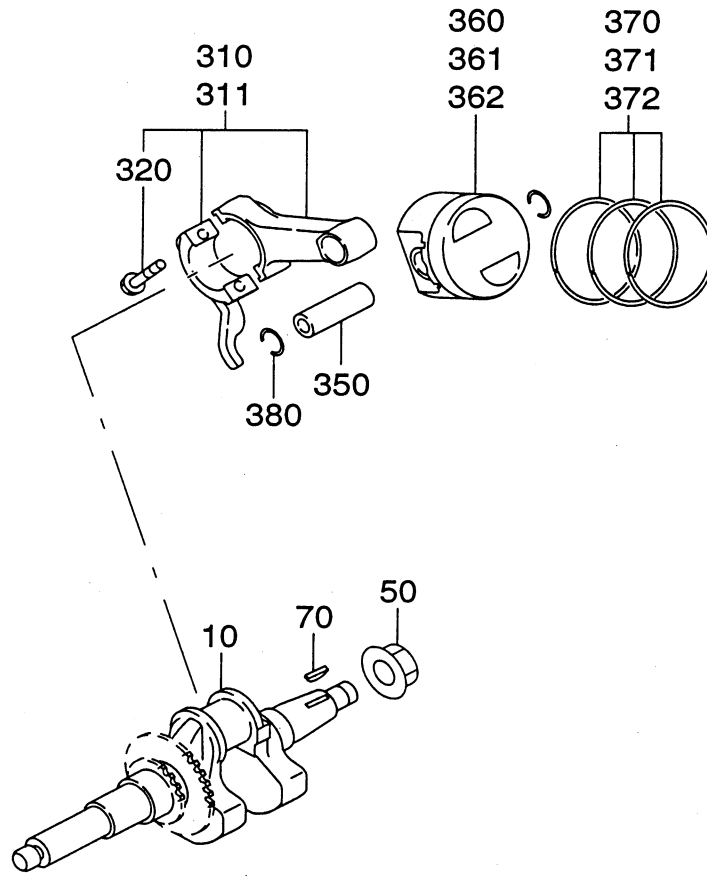

2 CRANKSHAFT, PISTON

REF. NO.	PART NUMBER		PART NAME		CODE NO. FROM - TO	QTY	REMARKS	INTERCHANGEABLE PART NUMBER	FIG. NO.
		PART NUMBER		SPEC. NO.					
10	277-20301-21		CRANK SHAFT CP		-	1	L=277 20DX55. 4L+M18		200
50	018-01400-20		FLANGE NUT		-	1	M14X1. 5X28DX12H		200
70	032-30300-10		WOODRUFF KEY		-	1	3BX6HX16D		200
310	277-22501-10		CONNECTING ROD AY		-	1	84.5CDX25B 30D-16D		200
311	277-22502-00		CONNECTING ROD AY		-	1	0.25 U.S.		200
320	277-23001-03		CONNECTING ROD BOLT		-	2	M6X1. 0X13DX33L		200
350	277-23301-13		PISTON PIN		6666-	1	16DX11DX48. 5L		200
	277-23301-03		PISTON PIN		-6665	1	16DX11DX48. 5L	277-23301-13	200
360	277-23401-J3		PISTON		6545-	1	STD (67DX40H)		200
	277-23401-H3		PISTON		-6544	1	STD (67DX40H)	277-23401-J3	200
361	277-23403-J3		PISTON		6545-	1	0.25 O.S. (67DX40H)		200
	277-23403-H3		PISTON		-6544	1	0.25 O.S. (67DX40H)	277-23403-J3	200
362	277-23404-J3		PISTON		6545-	1	0.50 O.S. (67DX40H)		200
	277-23404-H3		PISTON		-6544	1	0.50 O.S. (67DX40H)	277-23404-J3	200
370	277-23511-37		PISTON RING SET		-	1	STD(67D) OIL EXPANDE		200
371	277-23512-17		PISTON RING SET		-	1	0.25 O.S. OIL EXPAND		200
372	277-23513-17		PISTON RING SET		-	1	0.50 O.S. OIL EXPAND		200
380	056-51600-10		CLIP		-	2	17. 1DX1. 4D		200

FIG. 300

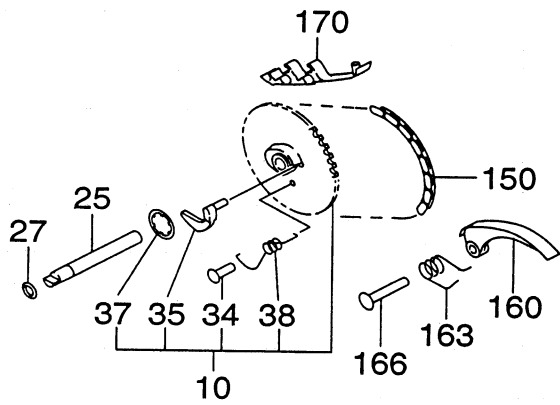
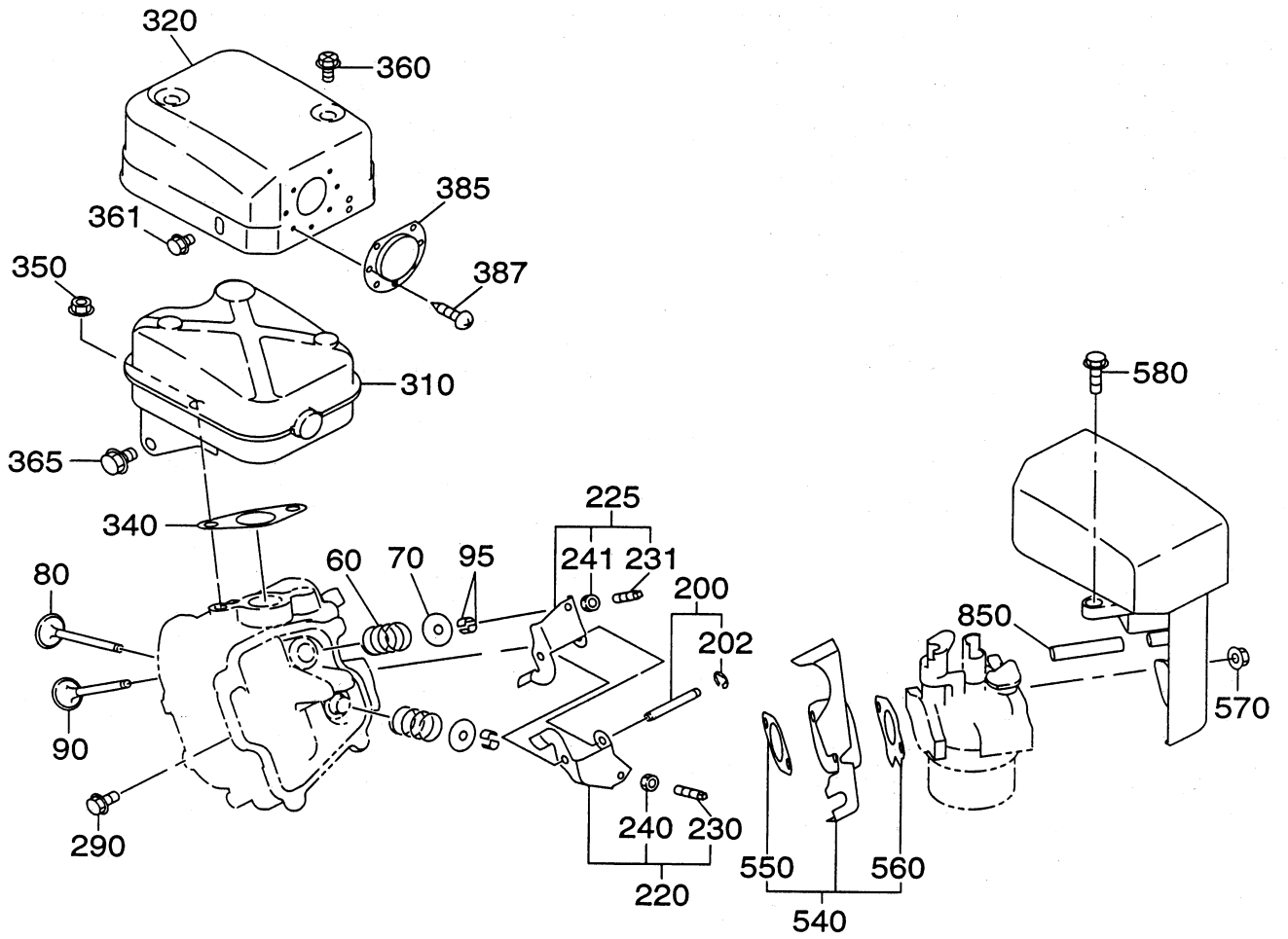
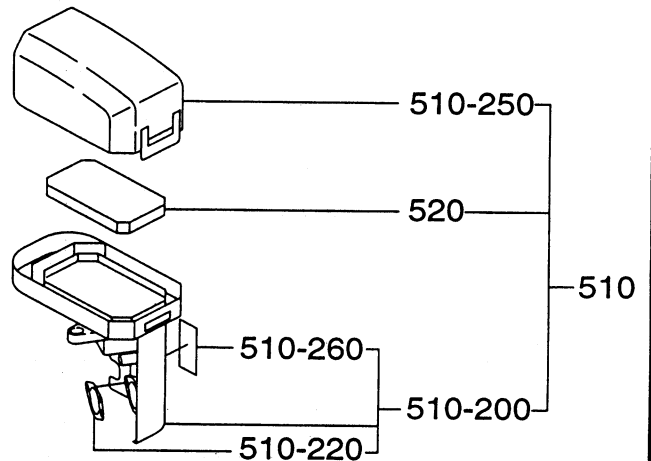

FIG. 315



3 INTAKE EXHAUST

REF. NO.	PART NUMBER		PART NAME		CODE NO. FROM - TO	QTY	REMARKS	INTERCHANGEABLE PART NUMBER	FIG. NO.
		PART NUMBER		SPEC. NO.					
10	277-31601-31		CAM SHAFT CP		6545-	1			300
	277-31601-11		CAM SHAFT CP		-6544	1	85DX2.9B N=40	277-31601-21	300
25	277-35101-03		PIN(CAM SHAFT)		-	1	9DX78.5L		300
27	024-00600-10		O RING		-	1	5.8DX9.6D		300
34	277-38601-03		PIN(SPRING)		-	1	4DX8DX9L		300
35	277-36401-03		RELEASE LEVER		-	1			300
37	277-36501-03		CLIP		-	1	13.8DX20.3DX0.4T		300
38	277-38702-03		RETURN SPRING		-	1	5.1DX0.6DX4.4L N=7		300
60	279-33601-03		VALVE SPRING		-	2	19.2DX2.3DX27.4L		300
70	269-33701-03		SPRING RETAINER		-	2			300
80	277-33401-H3		INTAKE VALVE		6291-	1	25.5DX5.5DX68.1L		300
	277-33401-13		INTAKE VALVE		-6290	1	25.5DX5.5DX68.1L	277-33401-H3	300
90	277-33501-H3		EXHAUST VALVE		6291-	1	23.5DX5.5DX68.1L		300
	277-33501-13		EXHAUST VALVE		-6290	1	23.5DX5.5DX68.1L	277-33501-H3	300
95	132-10KA0-31		COLLET-VALVE		-	4			300
150	277-35601-11		TIMING CHAIN CP		-	1	88 LINK		300
160	277-36911-03		TENTIONER		-	1			300
163	277-37101-03		SPRING(TENTIONER)		-	1	10DX1.8DX14L N=4.5		300
166	277-36902-03		PIN(TENTIONER)		-	1	6DX13DX34L		300
170	277-36913-13		CHAIN GUIDE		-	1			300
200	277-35002-01		PIN(ROCKER) CP		-	1	6DX46L		300
202	003-13050-00		CLIP		-	1			300
220	277-36201-00		ROCKER ARM(IN) AY		-	1			300
225	277-36202-00		ROCKER ARM(EX) AY		-	1			300
230	014-90500-20		ADJUST SCREW		-	1	M5X0.5X23L		300
231	014-90500-20		ADJUST SCREW		-	1	M5X0.5X23L		300
240	017-00500-30		NUT		-	1	M5X0.5X4.1H		300
241	017-00500-30		NUT		-	1	M5X0.5X4.1H		300
290	011-00600-20		FLANGE BOLT		-	1	M6X1.0X14DX12L		300
310	277-30101-H1		MUFFLER CP		6484-	1			300
	277-30101-21		MUFFLER CP		-6483	1		277-30101-H1	300
320	277-34201-11		MUFFLER COVER CP		-	1			300
340	277-35201-13		GASKET(MUFFLER)		-	1	T=0.2 26D 9DX58P		300
350	980-20082-80		FLANGE NUT		-	2			300
360	015-20600-90		TAPPING BOLT		-	2	M6X13DX10L		300
361	011-00600-10		FLANGE BOLT		-	1	M6X1.0X14DX8L		300

3 INTAKE EXHAUST

REF. NO.	PART NUMBER		PART NAME		CODE NO. FROM - TO	QTY	REMARKS	INTERCHANGEABLE PART NUMBER	FIG. NO.
		PART NUMBER		SPEC. NO.					
365	011-00803-20		FLANGE BOLT		6210-	1	M8X1.25X16DX12L		300
	011-00801-50		FLANGE BOLT		-6209	1	M8X1.25X16DX12L		300
385	277-37203-H1		SCREEN CP		6179-	1			300
	277-37203-01		SCREEN CP		-6178	1		277-37203-H1	300
387	015-00400-60		TAPPING SCREW		-	2	M4X6L		300
510	277-32611-00		AIR CLEANER AY		-	1	URETHANE FOAM		315
-200	277-32610-08		PACKING		-	1			315
-220	277-32604-08		PACKING		-	1			315
-250	277-32602-08		COVER CP		-	1			315
-260	277-32609-08		LABEL		-	1			315
520	277-32603-08		ELEMENT		-	1	URETHANE FOAM		315
540	277-32902-J1		INSULATOR CP		6301-	1			300
	277-32902-H1		INSULATOR CP		-6300	1		277-32902-J1	300
550	277-35903-J3		GASKET2 (INSULATOR)		6301-	1	T=0.5		300
	277-35903-H3		GASKET2 (INSULATOR)		-6300	1	T=0.5	277-35903-J3	300
560	277-35902-J3		GASKET1 (INSULATOR)		6301-	1	T=0.5		300
	277-35902-H3		GASKET1 (INSULATOR)		-6300	1	T=0.5	277-35902-J3	300
570	002-38060-00		FLANGE NUT		-	2			300
580	011-00600-50		FLANGE BOLT		-	1	M6X1.0X13DX20L		300
850	277-32760-08		BREATHHER PIPE		-	1			300

FIG. 400

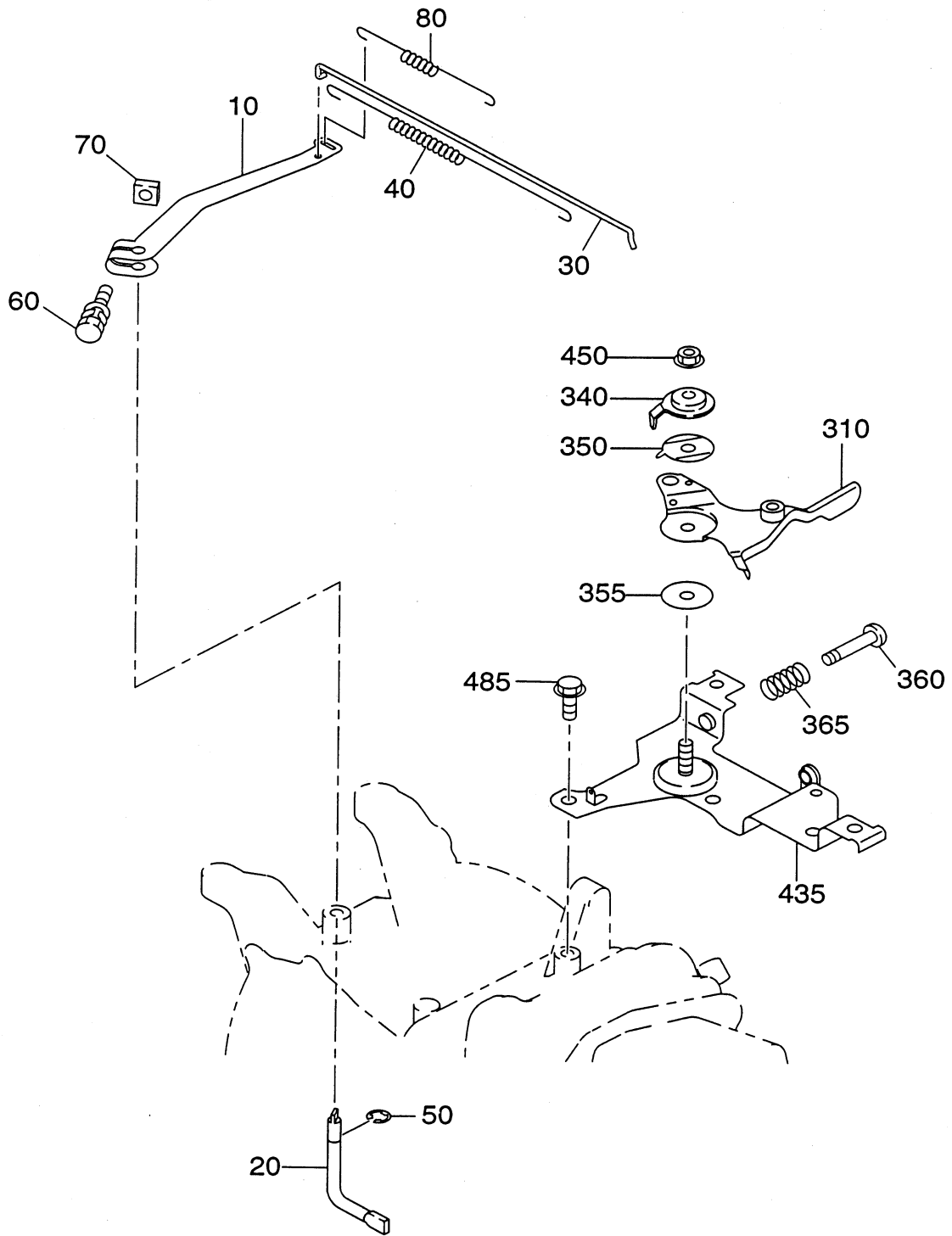

4 GOVERNOR OPERATION

REF. NO.	PART NUMBER		PART NAME		CODE NO. FROM - TO	QTY	REMARKS	INTERCHANGEABLE PART NUMBER	FIG. NO.
		PART NUMBER		SPEC. NO.					
10		277-42301-23		GOVERNOR LEVER	6088-	1			400
		277-42301-13		GOVERNOR LEVER	-6087	1		277-42301-23	400
20		277-42201-33		GOVERNOR SHAFT	-	1			400
30		277-42701-11		GOVERNOR ROD CP	6241-	1			400
		277-42701-01		GOVERNOR ROD CP	-6240	1		277-42701-11	400
40		277-42801-23		ROD SPRING	6241-	1	7DX0.5DX182L N=16		400
		277-42801-13		ROD SPRING	-6240	1	7DX0.5DX182L N=16	277-42801-23	400
50		003-13050-00		CLIP	-	1			400
60		013-00602-40		BOLT AND WASHER AY	-	1	M6X1.0X25L W/TWO W		400
70		018-60600-20		NUT	-	1	M6X1.0X4.9H SQUARE		400
80		277-42510-13		GOVERNOR SPRING	6270-	1	7.5DX0.7DX115L N=16		400
		277-42510-03		GOVERNOR SPRING	6118-6269	1	7.5DX0.7DX115L N=16	277-42510-13	400
		279-42502-43		GOVERNOR SPRING	-6117	1	7.5DX0.7DX115L N=20	279-42502-53	400
310		277-43303-03		SPEED CONTROL LEVER	-	1			400
340		277-43502-03		STOP PLATE	6210-	1			400
		277-43501-03		STOP PLATE	-6209	1		277-43502-03	400
350		277-44501-03		WASHER	6392-	1			400
		020-00601-70		WASHER	-6391	1	6DX24DX0.4T		400
355		021-70600-70		FRICTION WASHER	-	1	6.5DX24DX0.8T NYLON		400
360		004-31062-50		SCREW	-	1			400
365		237-45004-23		SPRING (ADJUST)	-	1	6.9DX0.9DX20L N=7		400
435		277-46002-02		SPEED CONT. BRKT UN	-	1			400
450		002-35060-00		SELF LOCK NUT	-	1			400
485		011-00600-20		FLANGE BOLT	-	2	M6X1.0X14DX12L		400

FIG. 500

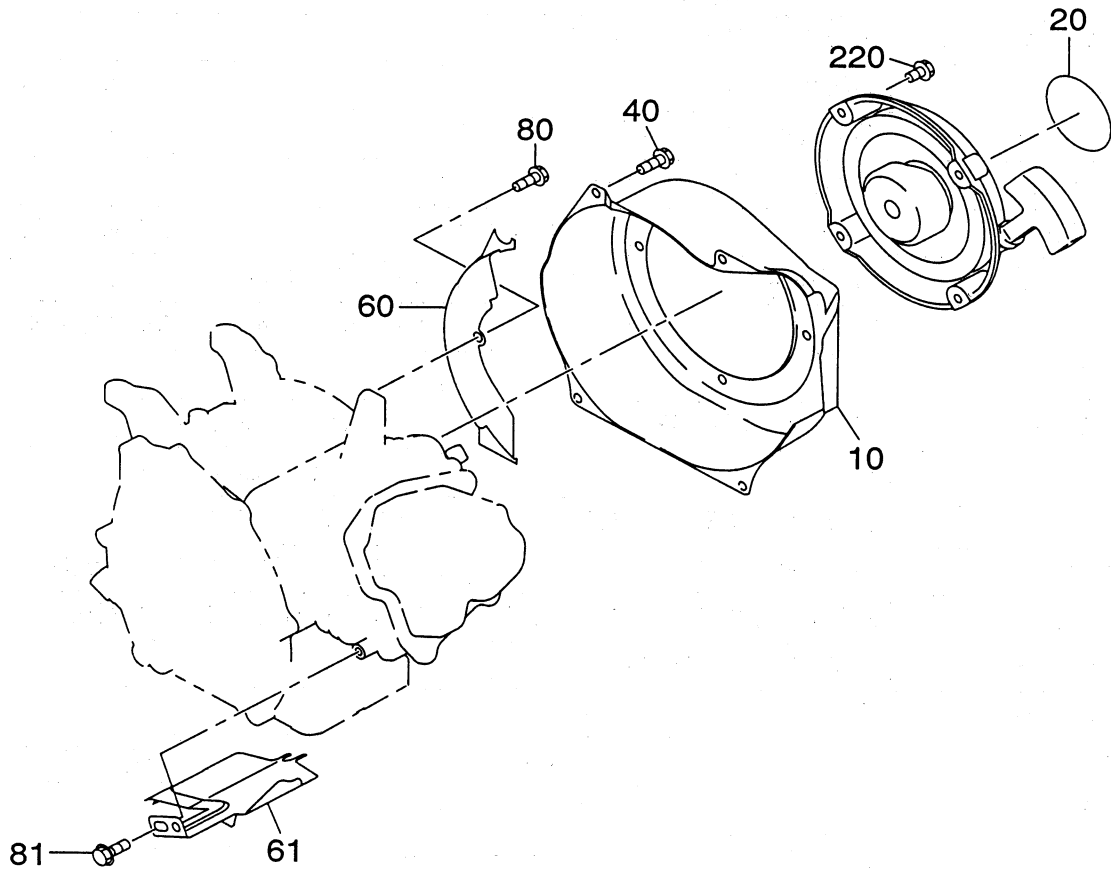
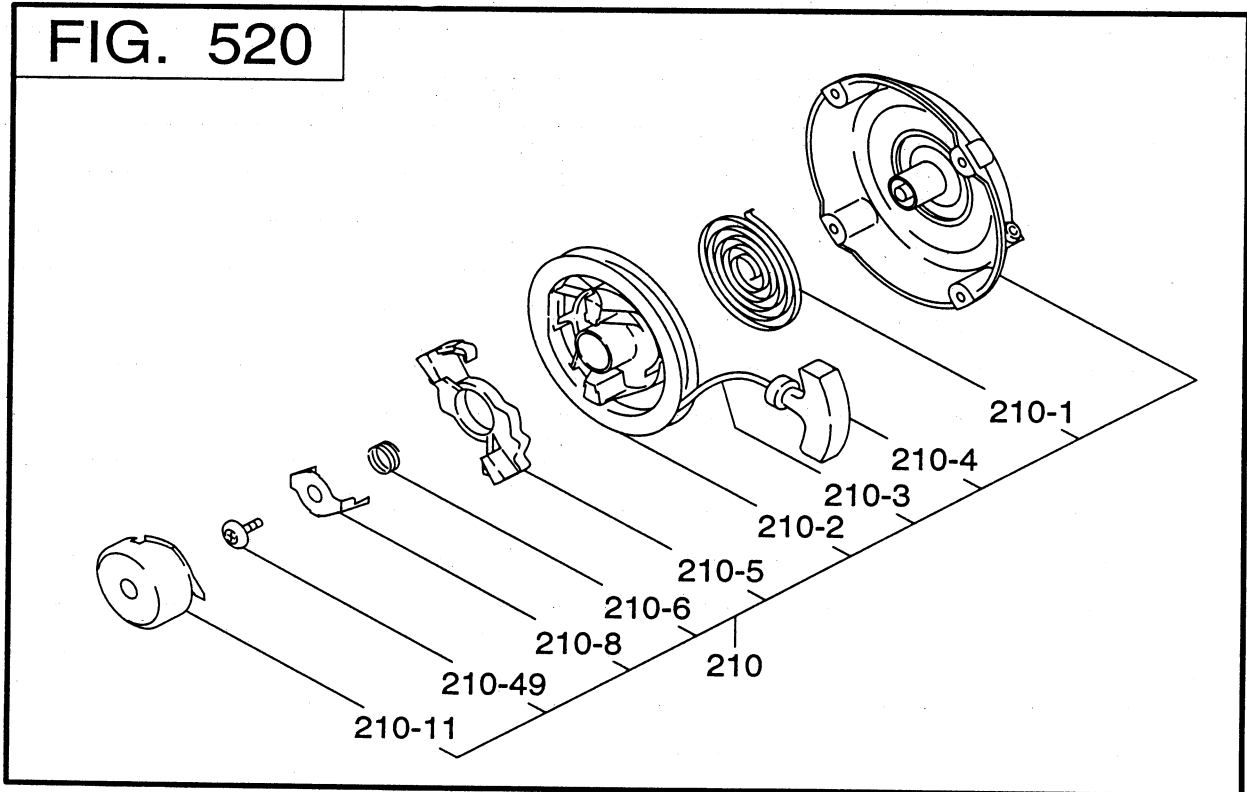

FIG. 520



5 COOLING STARTING

REF. NO.	PART NUMBER		PART NAME		CODE NO. FROM - TO	QTY	REMARKS	INTERCHANGEABLE PART NUMBER	FIG. NO.
		PART NUMBER		SPEC. NO.					
10		277-51201-11		BLOWER HOUSING CP	-	1	ROBIN YELLOW		500
20		073-20054-70		LABEL (TRADE MARK)	-	1	60D		500
40		011-00600-30		FLANGE BOLT	-	4	M6X1. 0X14DX14L		500
60		277-52711-21		BAFFLE 1(CASE) CP	6671-	1			500
		277-52711-11		BAFFLE 1(CASE) CP	-6670	1		277-52711-21	500
61		277-52702-03		BAFFLE 2(HEAD)	-	1			500
80		001-04061-60		FLANGE BOLT	-	1			500
81		011-00600-20		FLANGE BOLT	-	1	M6X1. 0X14DX12L		500
210		277-50301-00		RECOIL STARTER AY	-	1	160PD RESIN		520
- 1		226-50716-08		SPIRAL SPRING	-	1			520
- 2		277-50121-08		REEL	-	1			520
- 3		277-50110-08		STARTER ROPE	-	1			520
- 4		281-50300-08		STARTER KNOB	-	1			520
- 5		281-50325-08		RATCHET	-	1			520
- 6		281-50330-08		FRICTION SPRING	-	1			520
- 8		281-50340-08		FRICTION PLATE	-	1			520
- 11		277-50145-08		STARTER PULLEY	-	1			520
- 49		281-50351-08		CENTER SCREW	-	1			520
220		013-00602-80		BOLT AND WASHER AY	-	4	M6X1. 0X14L W/SW		500

FIG. 600

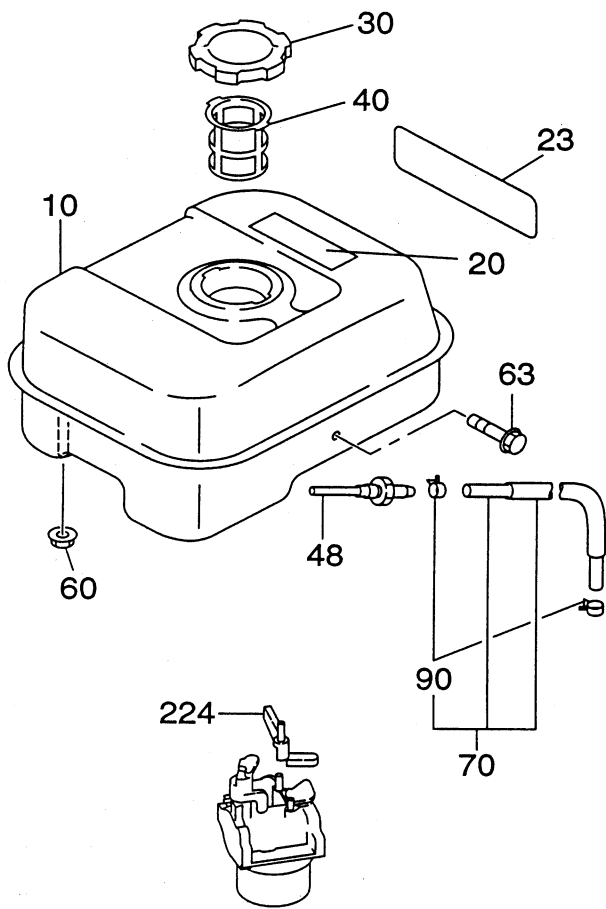
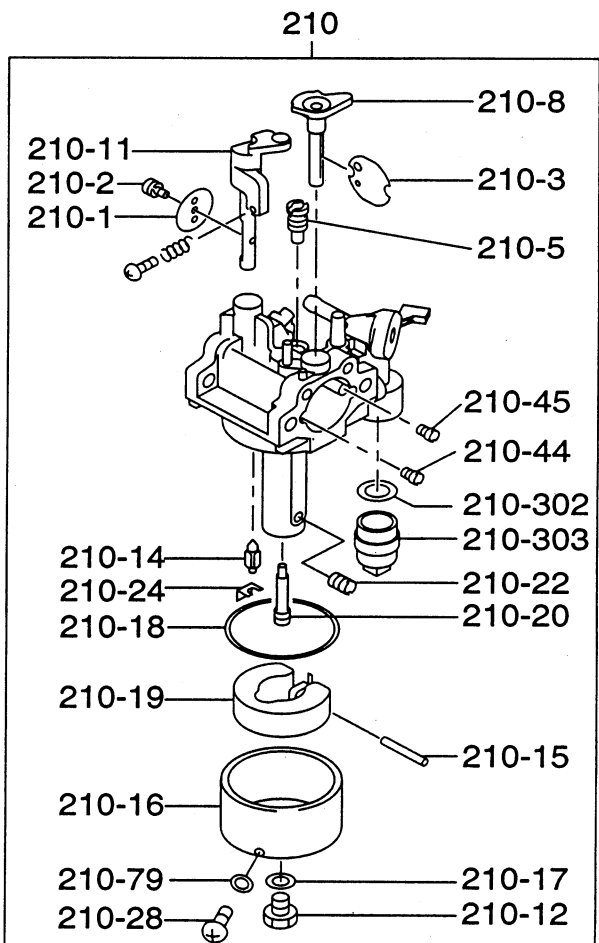

FIG. 640



6 FUEL LUBRICANT

REF. NO.	PART NUMBER		PART NAME		CODE NO. FROM - TO	QTY	REMARKS	INTERCHANGEABLE PART NUMBER	FIG. NO.
		PART NUMBER		SPEC. NO.					
10		277-60101-11		FUEL TANK CP	-	1	3.6L ROBIN YELLOW		600
20		073-20051-81		LABEL(WARNING)	-	1	42X104 ENGLISH		600
23		277-95111-03		LABEL(MODEL)	-	1			600
30		043-04400-50		FUEL TANK CAP CP	-	1	43DX68DX14H BLACK		600
40		X64-13600-10		FUEL FILTER	6331-	1			600
		064-13600-10		FUEL FILTER	-6330	1	36DX46DX43H		600
48		050-51200-20		UNION	-	1	M12X4DX78L W/FILTER		600
60		002-38060-00		FLANGE NUT	-	2			600
63		011-00601-30		FLANGE BOLT	-	1	M6X1.0X14DX25L		600
70		277-62605-K1		FUEL PIPE CP	6270-	1	6DX11DX150L		600
		277-62605-J1		FUEL PIPE CP	-6269	1	6DX11DX150L		600
90		X56-11100-20		HOSE CLAMP	-	2	10.5DX8BX0.7T		600
210		277-62301-20		CARBURETOR AY	6289-	1			640
		277-62301-10		CARBURETOR AY	-6288	1		277-62301-20	640
- 1		277-62535-08		THROTTLE VALVE	-	1	#160		640
- 2		209-62351-08		SCREW	-	1			640
- 3		277-62525-08		CHOKE VALVE	-	1			640
- 5		246-62420-08		PILOT JET	-	1	#40		640
- 8		277-62520-08		CHOKE LEVER	-	1			640
- 11		277-62530-18		THROTTLE SHAFT-A	-	1			640
- 12		227-62451-08		BOLT	-	1			640
- 14		277-62500-08		NEEDLE	-	1			640
- 15		277-62515-08		PIN	-	1			640
- 16		277-62506-08		FLOAT BODY	-	1			640
- 17		214-62450-08		PACKING	-	1			640
- 18		214-62540-08		CHAMBER PACKING	-	1			640
- 19		226-62506-08		FLOAT AY	-	1			640
- 20		277-62440-08		MAIN NOZZLE	-	1			640
- 22		277-62402-08		MAIN JET	-	1	#81.3		640
- 24		226-62701-18		CLIP	-	1			640
- 28		277-62360-08		BOLT	-	1			640
- 44		248-62410-08		AIR JET	-	1			640
- 45		106-62410-08		AIR JET(PILOT)	-	1			640
- 79		236-62541-08		PACKING	-	1			640
-302		277-62110-08		PACKING	6289-	1			640
		064-20064-10		PACKING	-6288	1			640

FIG. 700

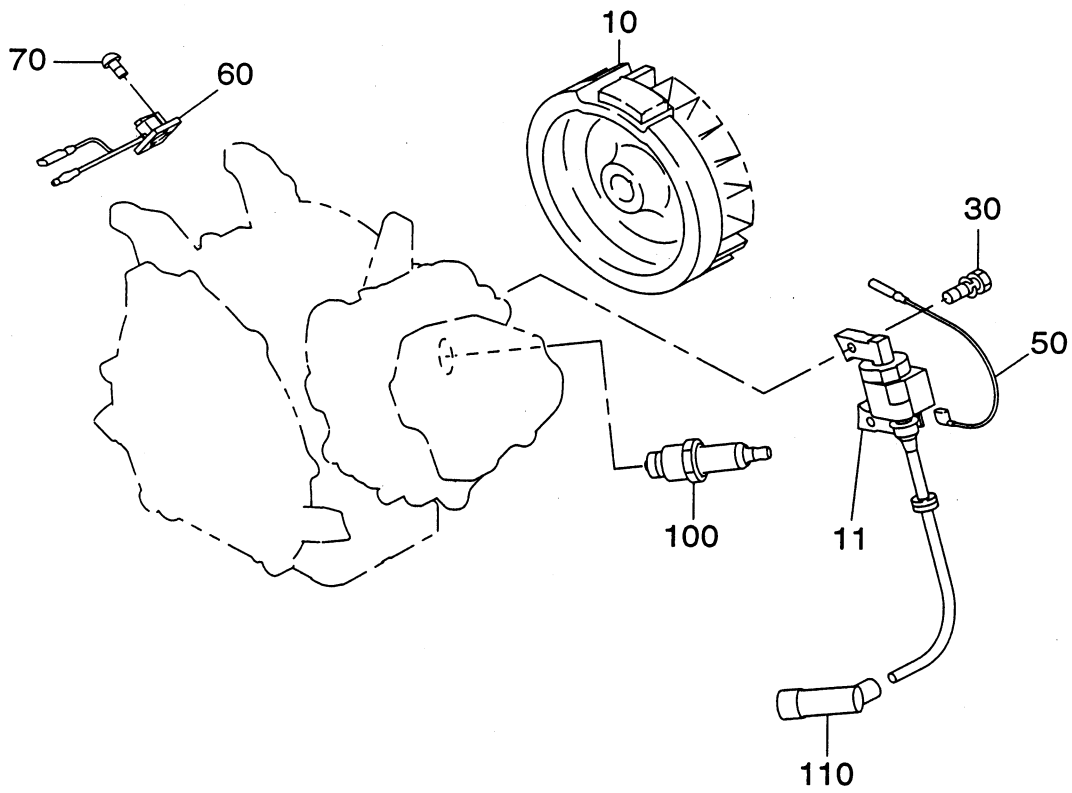
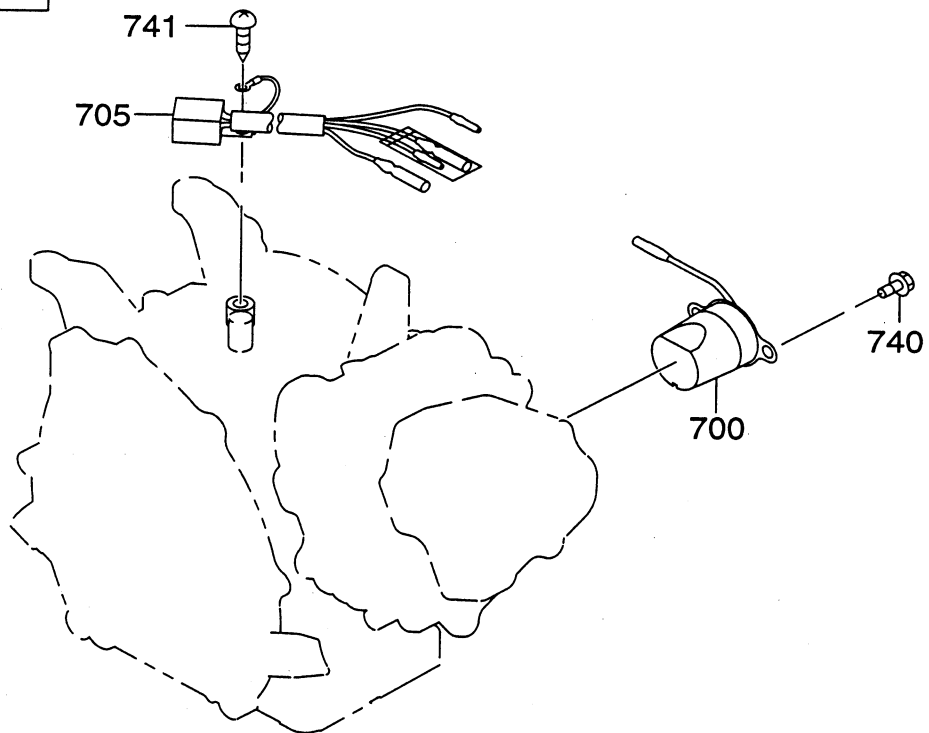

FIG. 770



7 ELECTRIC DEVICE

REF. NO.	PART NUMBER		PART NAME		CODE NO. FROM - TO	QTY	REMARKS	INTERCHANGEABLE PART NUMBER	FIG. NO.
		PART NUMBER		SPEC. NO.					
10		277-79230-11		FLYWHEEL CP	-	1	MARK MF5330		700
11		277-79431-01		IGNITION COIL CP	-	1	MARK BM3790		700
30		001-14062-50		BOLT AND WASHER AY	-	2			700
50		277-73101-H1		WIRE 1 CP	-	1	L=360 BLACK		700
		277-73102-H1		EX170D10130	-	1	L=360 BLACK		700
60		X66-00003-61		SWITCH AY	-	1			700
70		015-00400-90		TAPPING SCREW	-	2	M4X12L		700
100		065-01401-50		SPARK PLUG	-	1	NGK BR6HS		700
110		065-50002-70		SPARK PLUG CAP	-	1			700
700		*****		OIL SENSOR CP	-	1			
		277-76301-11		EX170D10130	-	1			770
705		*****		FLOAT C/U CP3	-	1			
		KU3-11043-11		EX170D10130	-	1			770
740		*****		BOLT AND WASHER AY	-	2			
		001-14061-60		EX170D10130	-	2			770
741		*****		TAPPING SCREW	-	1	M5X10DX10L		770
		015-20500-10		EX170D10130	-	1	M5X10DX10L		770
					-				
					-				
					-				
					-				
					-				
					-				
					-				
					-				
					-				
					-				
					-				
					-				
					-				
					-				
					-				
					-				
					-				

FIG. 900

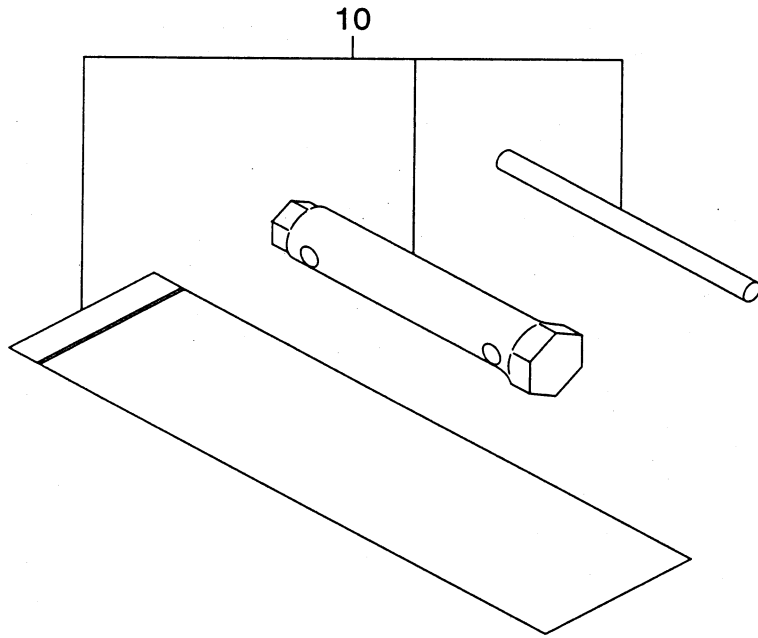
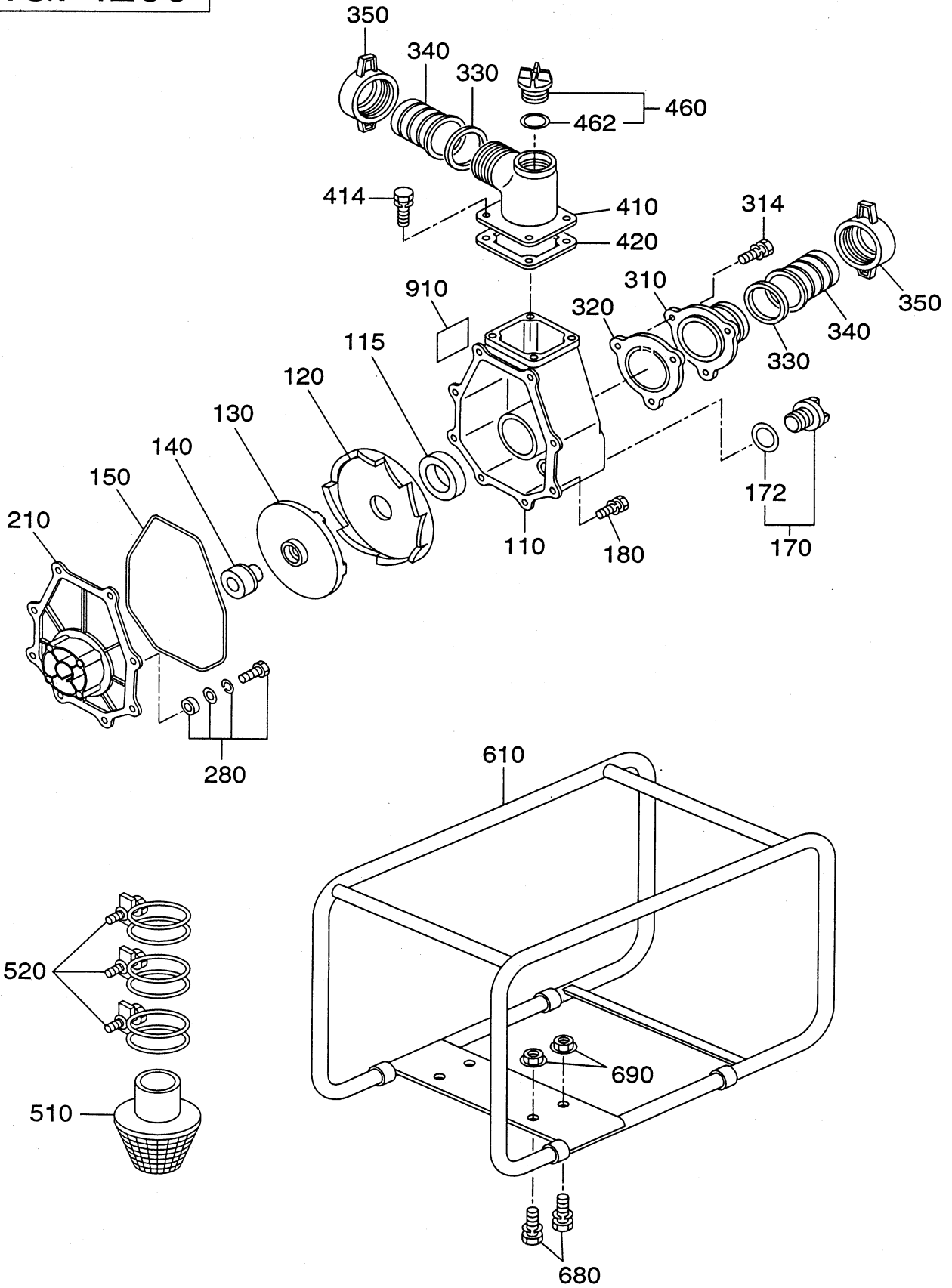

FIG. 4200



4 2 PUMP

REF. NO.	PART NUMBER		PART NAME		CODE NO. FROM - TO	QTY	REMARKS	INTERCHANGEABLE PART NUMBER	FIG. NO.
		PART NUMBER		SPEC. NO.					
110	480-05020-01		CASING		-	1			4200
115	480-05010-12		PACKING, INNER CASING		-	1			4200
120	480-05110-11		INNER CASING		-	1			4200
130	480-05110-09		IMPELLER		-	1			4200
140	480-05010-10		MECHANICAL SEAL		-	1			4200
150	480-05020-02		PACKING, CASING		-	1			4200
170	480-05010-21		PLUG, DRAIN		-	1			4200
172	480-05010-22		O-RING		-	1			4200
180	480-05010-14		HEX BOLT		-	8			4200
210	480-05110-04		CASING COVER		-	1			4200
280	480-05010-05		CASING BOLT AY		-	4			4200
310	480-05010-13		VALVE CASE		-	1			4200
314	480-05010-14		HEX BOLT		-	3			4200
320	480-05010-15		CHECK VALVE		-	1			4200
330	480-05010-17		PACKING, COUPLING		-	2			4200
340	481-00001-14		HOSE COUPLING (ABS)		-	2			4200
350	481-00001-15		COUPLING HANDLE (ABS)		-	2			4200
410	480-05010-19		BEND		-	1			4200
414	480-05010-14		HEX BOLT		-	4			4200
420	480-05010-20		PACKING, BEND		-	1			4200
460	480-05010-21		PLUG, DRAIN		-	1			4200
462	480-05010-22		O-RING		-	1			4200
510	480-05050-29		STRAINER		-	1			4200
520	480-05010-28		HOSE BAND		-	3			4200
610	481-00001-73		FRAME		-	1			4200
680	480-05010-23		HEX BOLT		-	4			4200
690	480-05010-24		FLANGE NUT		-	4			4200
910	484-00007-03		LABEL (PUMP NAME)		-	1			4200
	484-00016-03		PTX201H0010		-	1			4200

PART NUMBER INDEX LIST (FIG. No. 100~900)

PART NUMBER	PART NAME	FIG. REF.	PART NUMBER	PART NAME	FIG. REF.
KU3-11043-11	FLOAT C/U CP3	770 705	060-02800-21	BALL BEARING	100 40
X56-11100-20	HOSE CLAMP	600 90	064-13600-10	FUEL FILTER	600 40
X64-13600-10	FUEL FILTER	600 40	064-20064-10	PACKING	640 210 -302
X66-00003-61	SWITCH AY	700 60	064-20078-10	CUP	640 210 -303
001-04061-60	FLANGE BOLT	500 80	065-01401-50	SPARK PLUG	700 100
001-04083-50	FLANGE BOLT	100 300	065-50002-70	SPARK PLUG CAP	700 110
001-04083-50	FLANGE BOLT	100 631	073-20051-81	LABEL(WARNING)	600 20
001-14061-60	BOLT AND WASHER AY	770 740	073-20054-70	LABEL(TRADE MARK)	500 20
001-14062-50	BOLT AND WASHER AY	700 30	106-62410-08	AIR JET(PILOT)	640 210 - 45
002-35060-00	SELF LOCK NUT	400 450	132-10KA0-31	COLLET-VALVE	300 95
002-38060-00	FLANGE NUT	300 570	209-62351-08	SCREW	640 210 - 2
002-38060-00	FLANGE NUT	600 60	214-62450-08	PACKING	640 210 - 17
003-13050-00	CLIP	300 202	214-62540-08	CHAMBER PACKING	640 210 - 18
003-13050-00	CLIP	400 50	226-50716-08	SPIRAL SPRING	520 210 - 1
004-31062-50	SCREW	400 360	226-62506-08	FLOAT AY	640 210 - 19
010-50603-51	STUD	100 70	226-62701-18	CLIP	640 210 - 24
010-50802-50	STUD	100 60	227-62451-08	BOLT	640 210 - 12
011-00600-10	FLANGE BOLT	300 361	236-62541-08	PACKING	640 210 - 79
011-00600-20	FLANGE BOLT	100 710	237-14202-03	VALVE GUIDE	100 20
011-00600-20	FLANGE BOLT	300 290	237-45004-23	SPRING (ADJUST)	400 365
011-00600-20	FLANGE BOLT	400 485	246-62420-08	PILOT JET	640 210 - 5
011-00600-20	FLANGE BOLT	500 81	248-62410-08	AIR JET	640 210 - 44
011-00600-30	FLANGE BOLT	500 40	269-33701-03	SPRING RETAINER	300 70
011-00600-50	FLANGE BOLT	300 580	277-10101-41	CRANK CASE CP	100 10
011-00601-30	FLANGE BOLT	600 63	277-10102-41	CRANK CASE CP	100 10
011-00801-50	FLANGE BOLT	300 365	277-11001-31	MAIN BEARING COVER C	100 210
011-00802-40	FLANGE BOLT	100 630	277-13001-11	CYLINDER HEAD CP	100 610
011-00803-10	FLANGE BOLT	100 631	277-15001-23	GASKET (HEAD)	100 620
011-00803-20	FLANGE BOLT	300 365	277-15011-03	PIPE KNOCK	100 50
013-00602-40	BOLT AND WASHER AY	400 60	277-15011-03	PIPE KNOCK	100 700
013-00602-80	BOLT AND WASHER AY	500 220	277-15501-01	ROCKER COVER CP	100 680
014-90500-20	ADJUST SCREW	300 230	277-15503-01	ROCKER COVER CP	100 680
014-90500-20	ADJUST SCREW	300 231	277-16001-03	GASKET (ROCKER COVER)	100 690
015-00400-60	TAPPING SCREW	300 387	277-16001-13	GASKET (ROCKER COVER)	100 690
015-00400-90	TAPPING SCREW	700 70	277-16010-01	STEM SEAL	100 26
015-20500-10	TAPPING SCREW	770 741	277-20301-21	CRANK SHAFT CP	200 10
015-20600-90	TAPPING BOLT	300 360	277-22501-10	CONNECTING ROD AY	200 310
017-00500-30	NUT	300 240	277-22502-00	CONNECTING ROD AY	200 311
017-00500-30	NUT	300 241	277-23001-03	CONNECTING ROD BOLT	200 320
018-01400-20	FLANGE NUT	200 50	277-23301-03	PISTON PIN	200 350
018-60600-20	NUT	400 70	277-23301-13	PISTON PIN	200 350
020-00601-70	WASHER	400 350	277-23401-H3	PISTON	200 360
021-11400-20	GASKET	100 90	277-23401-J3	PISTON	200 360
021-31600-20	GASKET	100 280	277-23403-H3	PISTON	200 361
021-31600-20	GASKET	100 281	277-23403-J3	PISTON	200 361
021-70600-70	FRICITION WASHER	400 355	277-23404-H3	PISTON	200 362
024-00600-10	O RING	300 27	277-23404-J3	PISTON	200 362
032-30300-10	WOODRUFF KEY	200 70	277-23511-37	PISTON RING SET	200 370
040-11400-30	PLUG	100 80	277-23512-17	PISTON RING SET	200 371
043-04400-50	FUEL TANK CAP CP	600 30	277-23513-17	PISTON RING SET	200 372
044-00600-20	OIL SEAL	100 75	277-30101-H1	MUFFLER CP	300 310
044-02502-00	OIL SEAL	100 30	277-30101-21	MUFFLER CP	300 310
044-02502-10	OIL SEAL	100 220	277-31601-11	CAM SHAFT CP	300 10
050-51200-20	UNION	600 48	277-31601-31	CAM SHAFT CP	300 10
056-51600-10	CLIP	200 380	277-32602-08	COVER CP	315 510 -250
060-02501-40	BALL BEARING	100 230	277-32603-08	ELEMENT	315 520

PART NUMBER INDEX LIST (FIG.No. 100~900)

PART NUMBER	PART NAME	FIG. REF.	PART NUMBER	PART NAME	FIG. REF.
277-32604-08	PACKING	315 510 -220	277-52711-21	BAFFLE 1(CASE) CP	500 60
277-32609-08	LABEL	315 510 -260	277-60101-11	FUEL TANK CP	600 10
277-32610-08	PACKING	315 510 -200	277-62100-08	CUP	640 210 -303
277-32611-00	AIR CLEANER AY	315 510	277-62110-08	PACKING	640 210 -302
277-32760-08	BREATHER PIPE	300 850	277-62301-10	CARBURETOR AY	640 210
277-32902-H1	INSULATOR CP	300 540	277-62301-20	CARBURETOR AY	640 210
277-32902-J1	INSULATOR CP	300 540	277-62360-08	BOLT	640 210 - 28
277-33401-H3	INTAKE VALVE	300 80	277-62402-08	MAIN JET	640 210 - 22
277-33401-13	INTAKE VALVE	300 80	277-62440-08	MAIN NOZZLE	640 210 - 20
277-33501-H3	EXHAUST VALVE	300 90	277-62500-08	NEEDLE	640 210 - 14
277-33501-13	EXHAUST VALVE	300 90	277-62506-08	FLOAT BODY	640 210 - 16
277-34201-11	MUFFLER COVER CP	300 320	277-62515-08	PIN	640 210 - 15
277-35002-01	PIN(ROCKER) CP	300 200	277-62520-08	CHOKE LEVER	640 210 - 8
277-35101-03	PIN(CAM SHAFT)	300 25	277-62525-08	CHOKE VALVE	640 210 - 3
277-35201-13	GASKET(MUFFLER)	300 340	277-62530-18	THROTTLE SHAFT-A	640 210 - 11
277-35601-11	TIMING CHAIN CP	300 150	277-62535-08	THROTTLE VALVE	640 210 - 1
277-35902-H3	GASKET1(INSULATOR)	300 560	277-62605-J1	FUEL PIPE CP	600 70
277-35902-J3	GASKET1(INSULATOR)	300 560	277-62605-K1	FUEL PIPE CP	600 70
277-35903-H3	GASKET2(INSULATOR)	300 550	277-63601-13	OIL GAUGE	100 270
277-35903-J3	GASKET2(INSULATOR)	300 550	277-65001-03	FILLER PLUG	100 275
277-36201-00	ROCKER ARM(IN) AY	300 220	277-73101-H1	WIRE 1 CP	700 50
277-36202-00	ROCKER ARM(EX) AY	300 225	277-73102-H1	WIRE 2 CP	700 50
277-36401-03	RELEASE LEVER	300 35	277-76301-11	OIL SENSOR CP	770 700
277-36501-03	CLIP	300 37	277-79230-11	FLYWHEEL CP	700 10
277-36902-03	PIN(TENTIONER)	300 166	277-79431-01	IGNITION COIL CP	700 11
277-36911-03	TENTIONER	300 160	277-90301-H0	ACCESSORY TOOL KIT	900 10
277-36913-13	CHAIN GUIDE	300 170	277-95111-03	LABEL(MODEL)	600 23
277-37101-03	SPRING(TENTIONER)	300 163	277-99001-27	GASKET SET	100 960
277-37203-H1	SCREEN CP	300 385	279-33601-03	VALVE SPRING	300 60
277-37203-01	SCREEN CP	300 385	279-42502-43	GOVERNOR SPRING	400 80
277-38601-03	PIN(SPRING)	300 34	281-50300-08	STARTER KNOB	520 210 - 4
277-38702-03	RETURN SPRING	300 38	281-50325-08	RATCHET	520 210 - 5
277-41901-03	GOVERNOR SLEEVE	100 260	281-50330-08	FRICTION SPRING	520 210 - 6
277-42201-33	GOVERNOR SHAFT	400 20	281-50340-08	FRICTION PLATE	520 210 - 8
277-42301-13	GOVERNOR LEVER	400 10	281-50351-08	CENTER SCREW	520 210 - 49
277-42301-23	GOVERNOR LEVER	400 10	980-20082-80	FLANGE NUT	300 350
277-42510-03	GOVERNOR SPRING	400 80			
277-42510-13	GOVERNOR SPRING	400 80			
277-42701-01	GOVERNOR ROD CP	400 30			
277-42701-11	GOVERNOR ROD CP	400 30			
277-42801-13	ROD SPRING	400 40			
277-42801-23	ROD SPRING	400 40			
277-43303-03	SPEED CONTROL LEVER	400 310			
277-43501-03	STOP PLATE	400 340			
277-43502-03	STOP PLATE	400 340			
277-43801-01	CHOKE LEVER CP	600 224			
277-44501-03	WASHER	400 350			
277-45004-H1	GOVERNOR GEAR CP	100 250			
277-46002-02	SPEED CONT. BRKT UN	400 435			
277-50110-08	STARTER ROPE	520 210 - 3			
277-50121-08	REEL	520 210 - 2			
277-50145-08	STARTER PULLEY	520 210 - 11			
277-50301-00	RECOIL STARTER AY	520 210			
277-51201-11	BLOWER HOUSING CP	500 10			
277-52702-03	BAFFLE 2(HEAD)	500 61			
277-52711-11	BAFFLE 1(CASE) CP	500 60			

PART NUMBER INDEX LIST (FIG. No. 4200)

PART NUMBER	PART NAME	FIG. REF.	PART NUMBER	PART NAME	FIG. REF.
480-05010-05	CASING BOLT AY	4200 280			
480-05010-10	MECHANICAL SEAL	4200 140			
480-05010-12	PACKING, INNER CASING	4200 115			
480-05010-13	VALVE CASE	4200 310			
480-05010-14	HEX BOLT	4200 180			
480-05010-14	HEX BOLT	4200 314			
480-05010-14	HEX BOLT	4200 414			
480-05010-15	CHECK VALVE	4200 320			
480-05010-17	PACKING, COUPLING	4200 330			
480-05010-19	BEND	4200 410			
480-05010-20	PACKING, BEND	4200 420			
480-05010-21	PLUG, DRAIN	4200 170			
480-05010-21	PLUG, DRAIN	4200 460			
480-05010-22	O-RING	4200 172			
480-05010-22	O-RING	4200 462			
480-05010-23	HEX BOLT	4200 680			
480-05010-24	FLANGE NUT	4200 690			
480-05010-28	HOSE BAND	4200 520			
480-05020-01	CASING	4200 110			
480-05020-02	PACKING, CASING	4200 150			
480-05050-29	STRAINER	4200 510			
480-05110-04	CASING COVER	4200 210			
480-05110-09	IMPELLER	4200 130			
480-05110-11	INNER CASING	4200 120			
481-00001-14	HOSE COUPLING (ABS)	4200 340			
481-00001-15	COUPLING HANDLE (ABS)	4200 350			
481-00001-73	FRAME	4200 610			
484-00007-03	LABEL (PUMP NAME)	4200 910			
484-00016-03	LABEL (PUMP NAME)	4200 910			

FUJI HEAVY INDUSTRIES LTD.
INDUSTRIAL PRODUCTS COMPANY

4-410 Asahi, Kitamoto-shi,
Saitama, 364-8511, Japan

Phone +81(48) 593-7896

Fax +81(48) 593-7965

Web site <http://www.fhi.co.jp/robin/>