



Robin Generator

Model **R1700** *i*
For GBR
PARTS CATALOG

Spec. No. RAS17017000
(E/G Spec.No. EH092DN8520)

富士重工業株式会社
FUJI HEAVY INDUSTRIES LTD.

ISSUE EMD-GP6017	
ISSUE DATE	2004.4

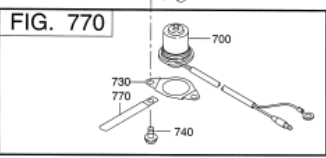
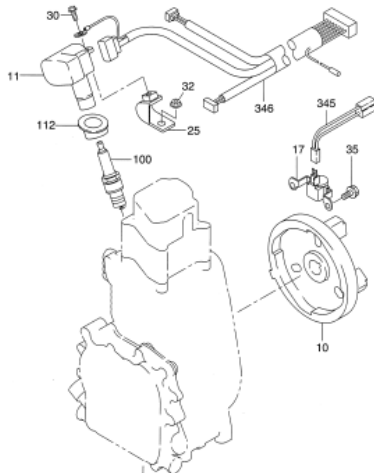
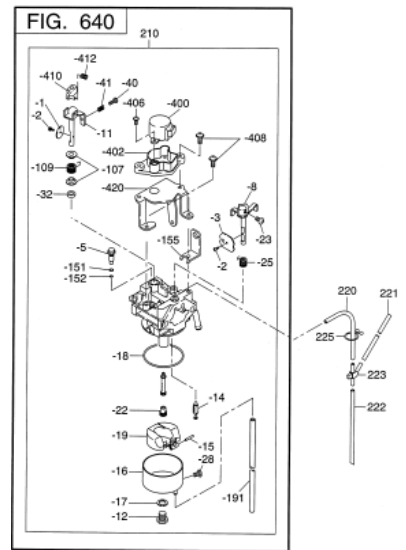
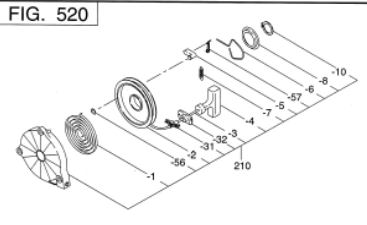
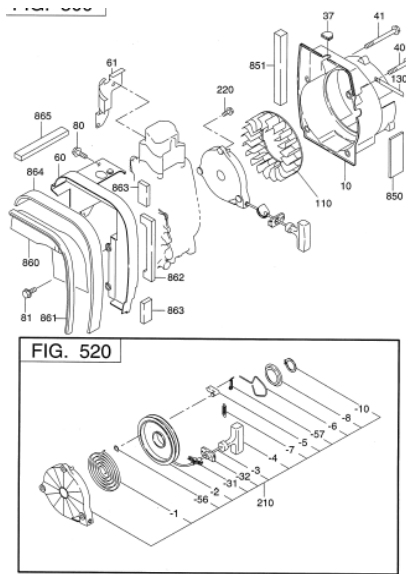
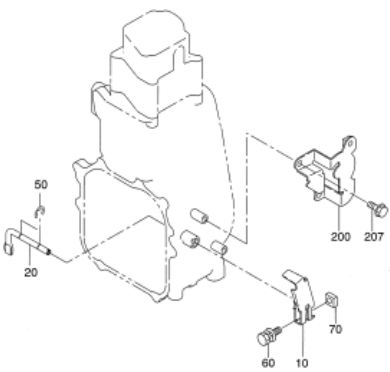
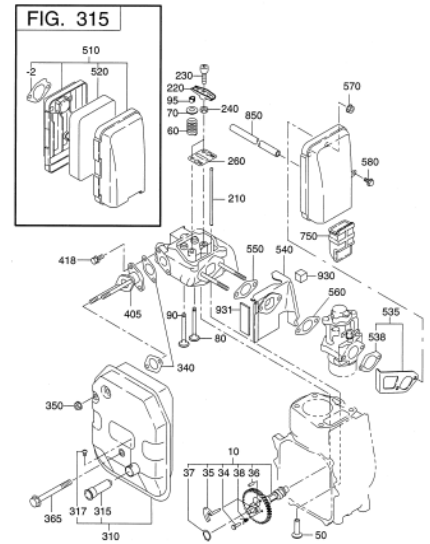
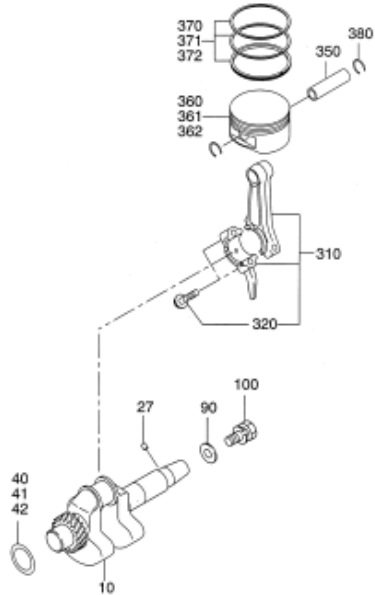
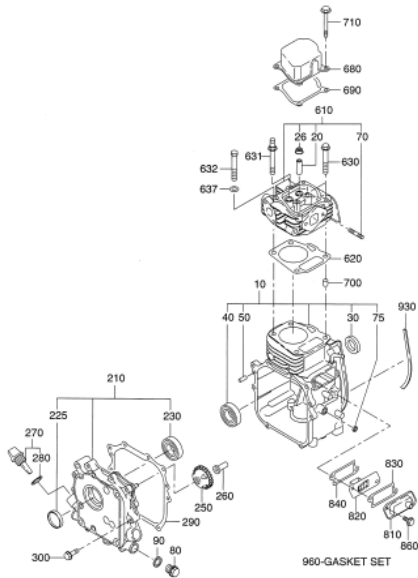

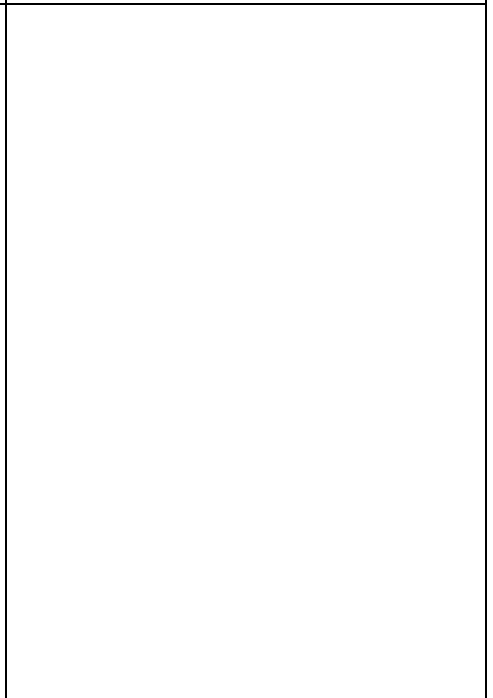
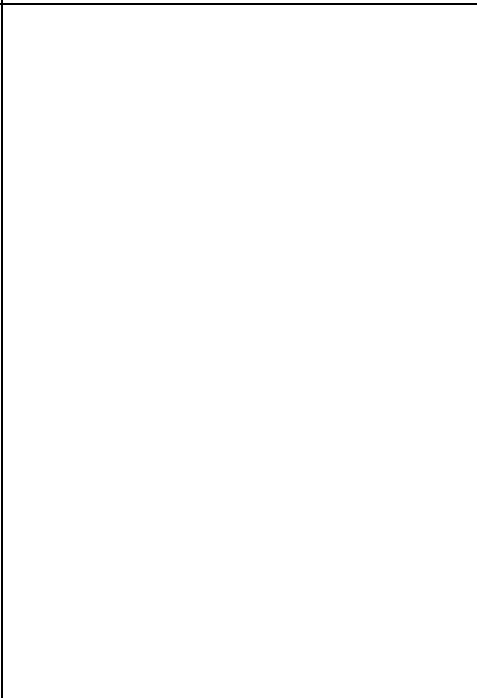
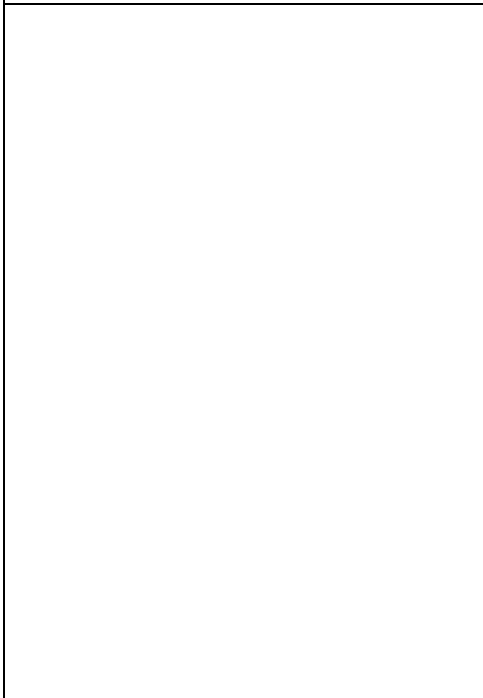
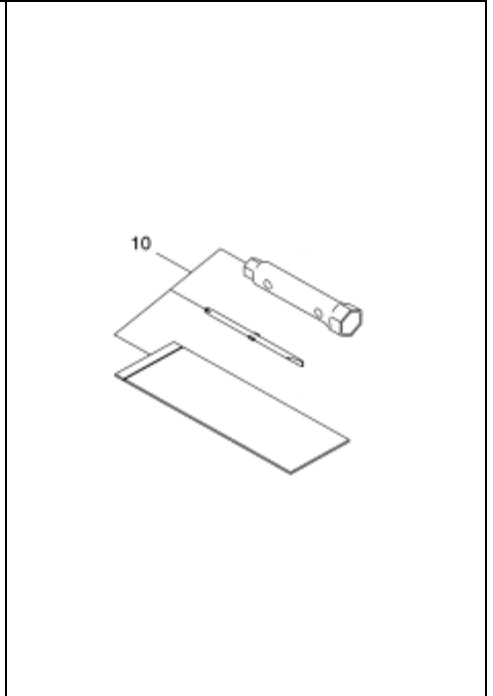
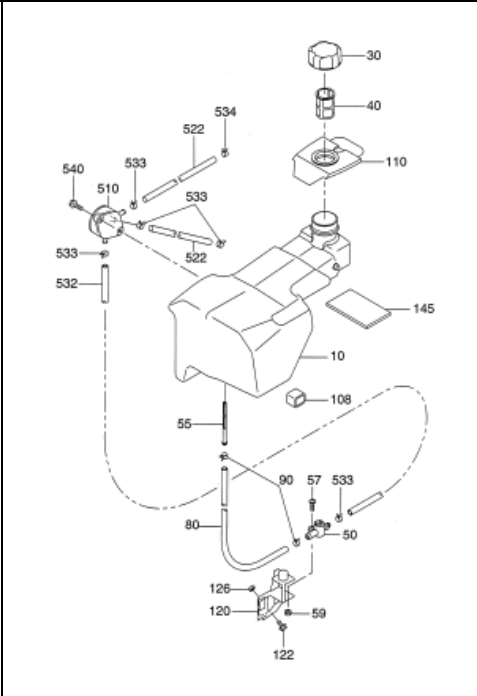
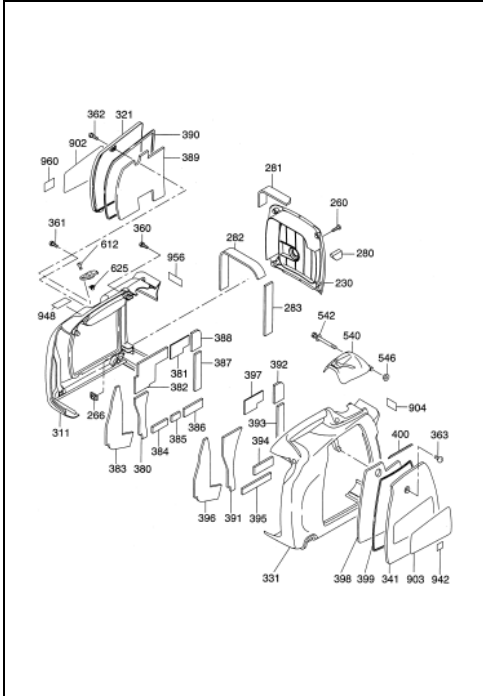
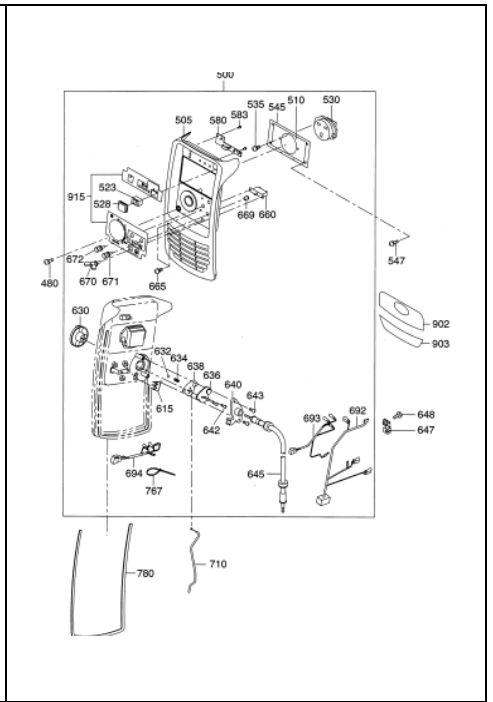
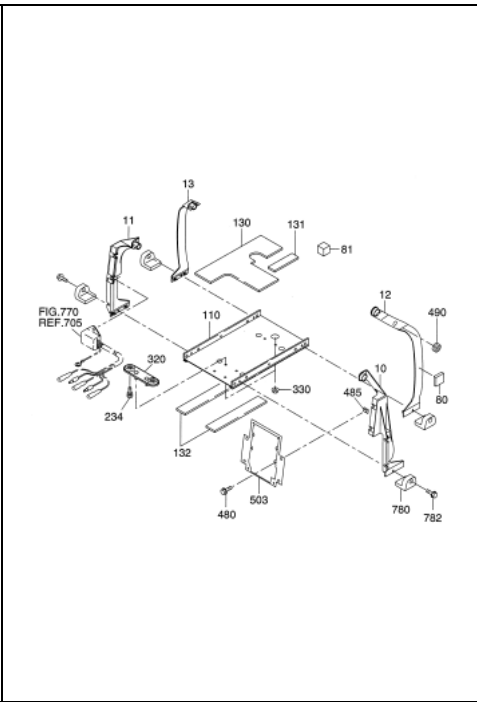
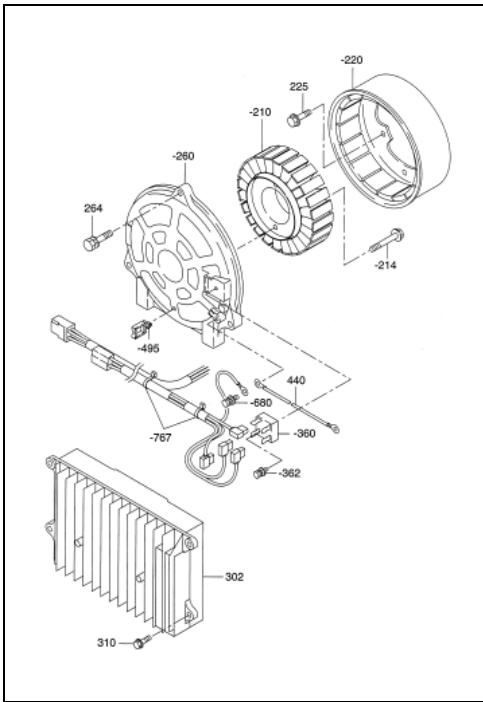
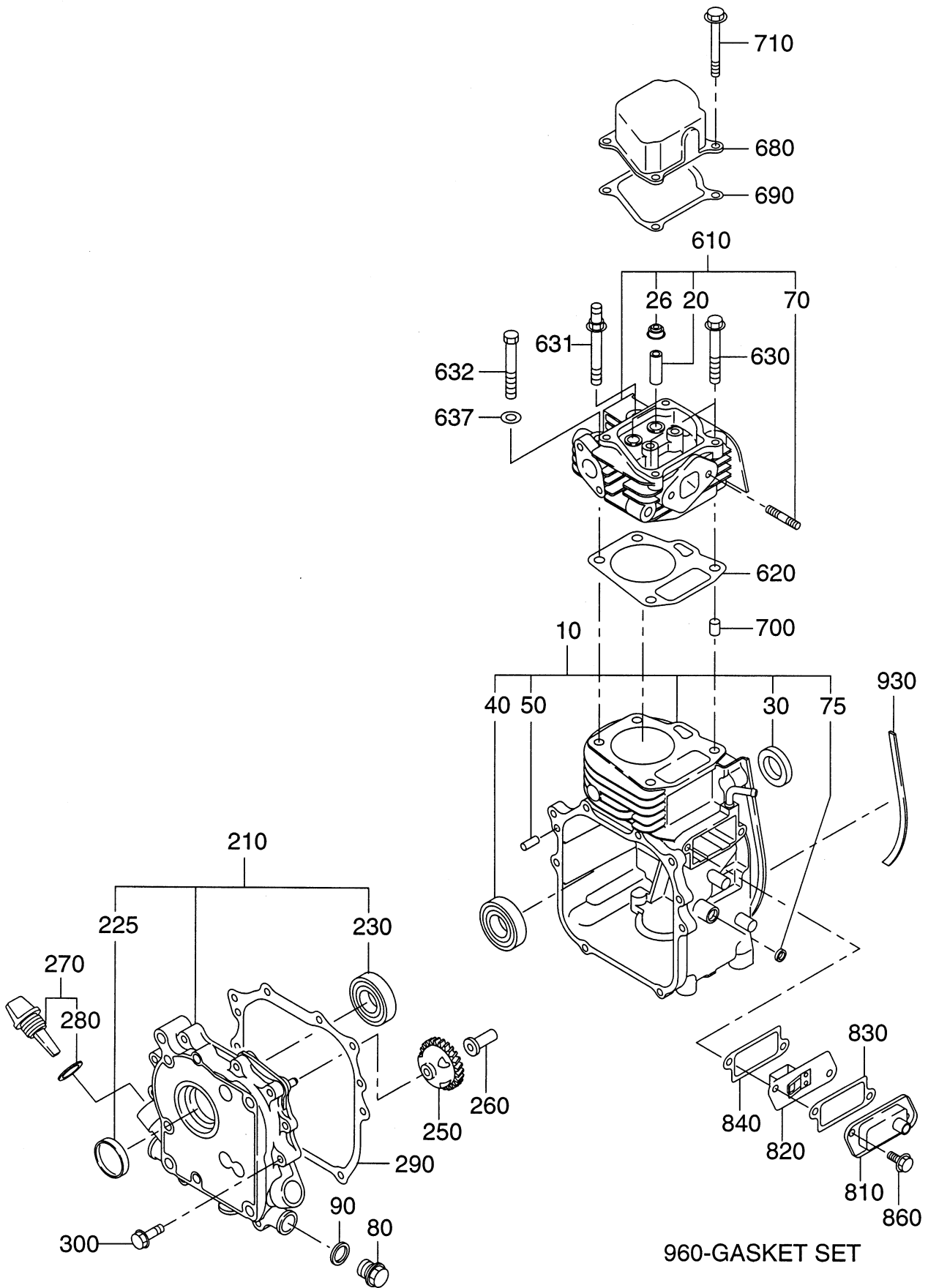

FIG. 100



1 CRANKCASE

REF.	PART NUMBER	PART NAME	QTY	REMARKS	CODE NO. FROM-TO	INTERCHANGEABLE PART NUMBER	UNIT PRICE	FIG.
10	284-10103-01	CRANKCASE CP	1		-			100
20	237-14202-03	VALVE GUIDE	2	5. 5DX9. 5DX27L	-			100
26	277-16010-01	STEM SEAL	1	5. 5DX9. 5DX15DX7. 8B	-			100
30	044-02000-70	OIL SEAL	1	20DX32DX6B	-			100
40	060-02001-40	BALL BEARING	1		-			100
50	031-00600-20	DOWEL PIN	2	6DX14. 5L	-			100
70	010-50604-20	STUD	2		-			100
75	044-00600-20	OIL SEAL	1	6DX10DX2. 5B	-			100
80	040-11400-30	PLUG	1	M14X1. 5X20DX12L	-			100
90	021-11400-20	GASKET	1	14. 1DX19DX2. 3T	-			100
210	284-11201-11	MAINBEARING COVER CP	1		-			100
225	230-17102-03	PLUG (RUBBER)	1		-			100
230	060-02001-40	BALL BEARING	1		-			100
250	284-45003-01	GOVERNOR GEAR CP	1		-			100
260	205-41901-03	GOVERNOR SLEEVE	1	6DX9DX16DX26L	-			100
270	230-63601-01	OIL GAUGE CP	1		-			100
280	021-31600-20	GASKET	1	16DX23DX1. 2T RUBBER	-			100
290	284-16003-03	GASKET (BEARING COVER)	1		-			100
300	011-00601-01	FLANGE BOLT	8	M6X1. 0X13DX28L	-			100
610	284-13003-01	CYLINDER HEAD CP	1		-			100
620	284-15001-13	GASKET (HEAD)	1		-			100
630	011-00802-10	FLANGE BOLT	2		-			100
631	011-00803-01	FLANGE BOLT	1		-			100
632	010-00804-20	BOLT	1		-			100
637	020-00802-10	WASHER	1		-			100
680	284-15501-03	ROCKER COVER	1		-			100
690	284-16004-03	GASKET (ROCKER COVER)	1	T=0. 7	-			100
700	277-15011-03	PIPE KNOCK	2	10. 3DX8. 5DX14L	-			100
710	011-00604-20	FLANGE BOLT	4		-			100
810	284-14301-01	BREATHER COVER CP	1		-			100
820	284-14401-01	BREATHER PLATE CP	1		-			100
830	230-16006-13	GASKET (TAPPET COVER)	1		-			100
840	230-16007-03	GASKET (BREATHER)	1		-			100
860	011-00600-20	FLANGE BOLT	2	M6X1. 0X14DX12L	-			100
930	33K-58317-03	SPONGE CRANK	1		-			100
960	284-99002-17	GASKET SET	1		-			100

FIG. 200

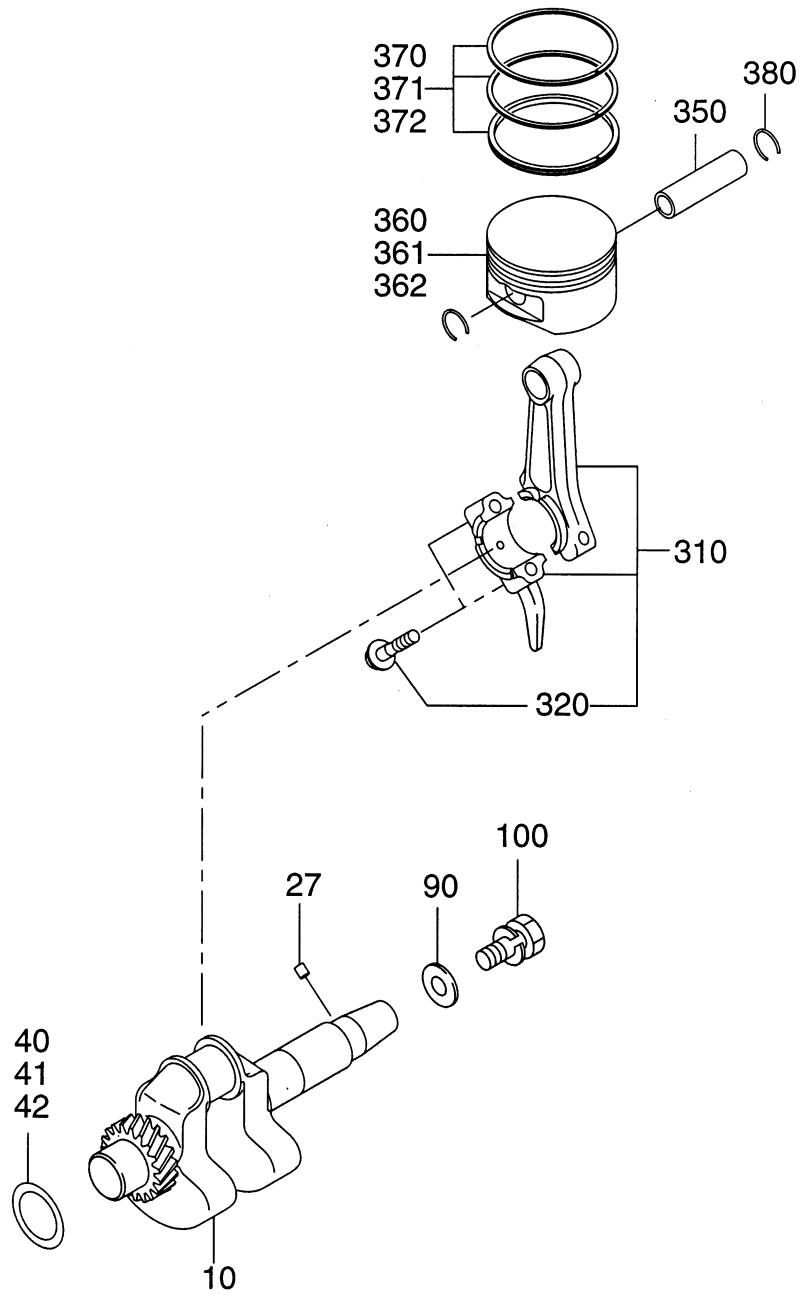
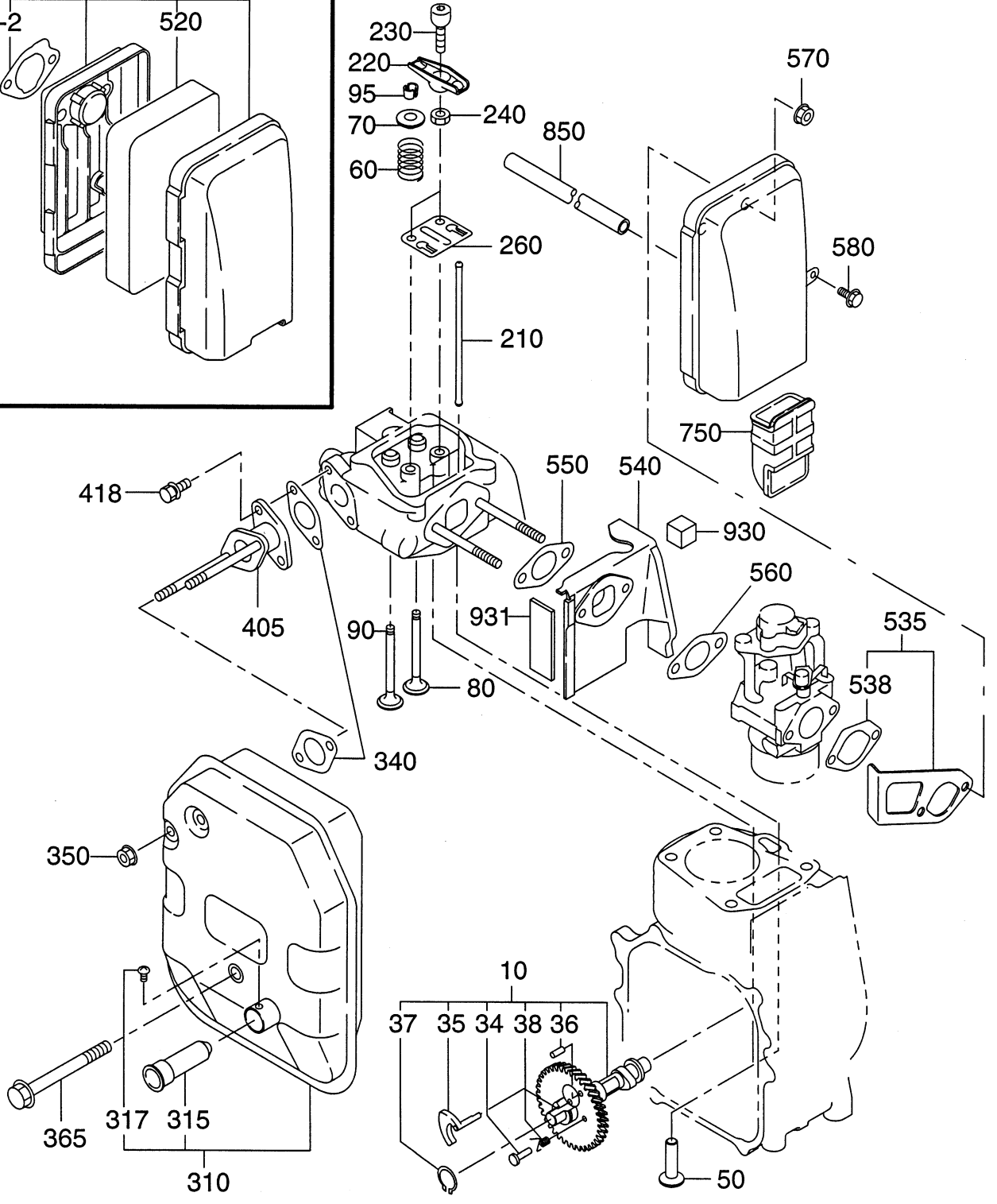
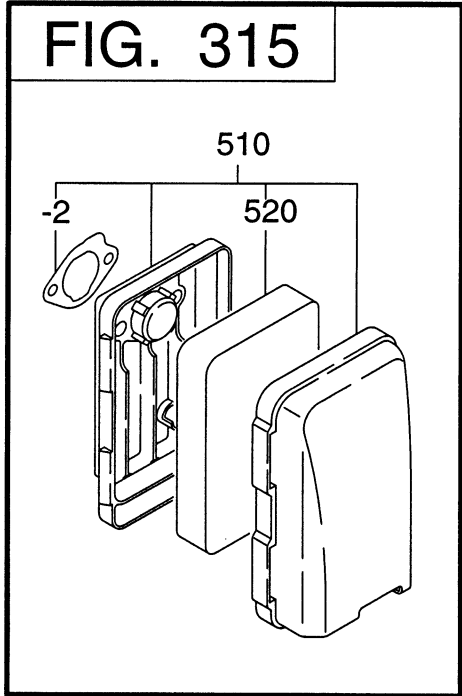

FIG. 300

FIG. 315



3 INTAKE EXHAUST

REF.	PART NUMBER	PART NAME	QTY	REMARKS	CODE NO. FROM-TO	INTERCHANGEABLE PART NUMBER	UNIT PRICE	FIG.
10	284-31701-11	CAMSHAFT CP	1	L=92 63DX6. 6B N=38	-			300
34	227-38601-23	PIN(SPRING)	1	3. 8DX7. 5DX14L	-			300
35	284-36401-03	RELEASE LEVER	1		-			300
36	005-19041-00	SPRING PIN	1		-			300
37	003-15170-00	SNAP RING OUTER	1		-			300
38	274-38701-23	RETURN SPRING	1		-			300
50	274-33301-03	TAPPET	2		-			300
60	274-33601-03	VALVE SPRING	2		-			300
70	274-33702-03	SPRING RETAINER	2		-			300
80	274-33401-03	INTAKE VALVE	1		-			300
90	274-33501-03	EXHAUST VALVE	1		-			300
95	132-10KA0-31	COLLET-VALVE	4		-			300
210	274-35301-03	PUSH ROD	2		-			300
220	274-36003-03	ROCKER ARM	2		-			300
230	269-35801-03	BOLT (PIVOT)	2	M6X0. 75X19L 13. 5D-S0	-			300
240	017-00600-90	NUT	2	M6X0. 75X5. 1H	-			300
260	274-36501-03	GUIDE PLATE	1		-			300
310	284-30201-20	MUFFLER AY	1		-			300
315	269-37601-01	SPARK ARRESTER CP	1		-			300
317	015-00400-60	TAPPING SCREW	1	M4X6L	-			300
340	230-35204-01	GASKET CP(EXHAUST)	2		-			300
350	018-00600-30	FLANGE NUT	2		-			300
365	011-00801-10	FLANGE BOLT	1	M8X1. 25X80L	-			300
405	284-34101-03	EXHAUST PIPE	1		-			300
418	001-14061-60	BOLT AND WASHER AY	2		-			300
510	284-32630-00	AIR CLEANER AY	1		-			315
- 2	227-36004-13	PACKING	1		-			315
520	284-32631-08	ELEMENT	1		-			315
535	284-32904-01	STAY BAFFLE CP	1		-			300
538	277-46701-03	GASKET (CHOKE)	1		-			300
540	284-32903-03	INSULATOR	1		-			300
550	227-35902-03	GASKET 2 (INSULATOR)	1	T=0. 3 25D 6. 5DX42P	-			300
560	236-35903-03	GASKET 2(INSULATOR)	1	T=0. 3 19. 5D 6. 5DX42P	-			300
570	002-38060-00	FLANGE NUT	2		-			300
580	011-00601-80	FLANGE BOLT	1	M6X1. 0X14DX18L	-			300
750	284-32101-03	DUCT	1		-			300

FIG. 300

FIG. 315

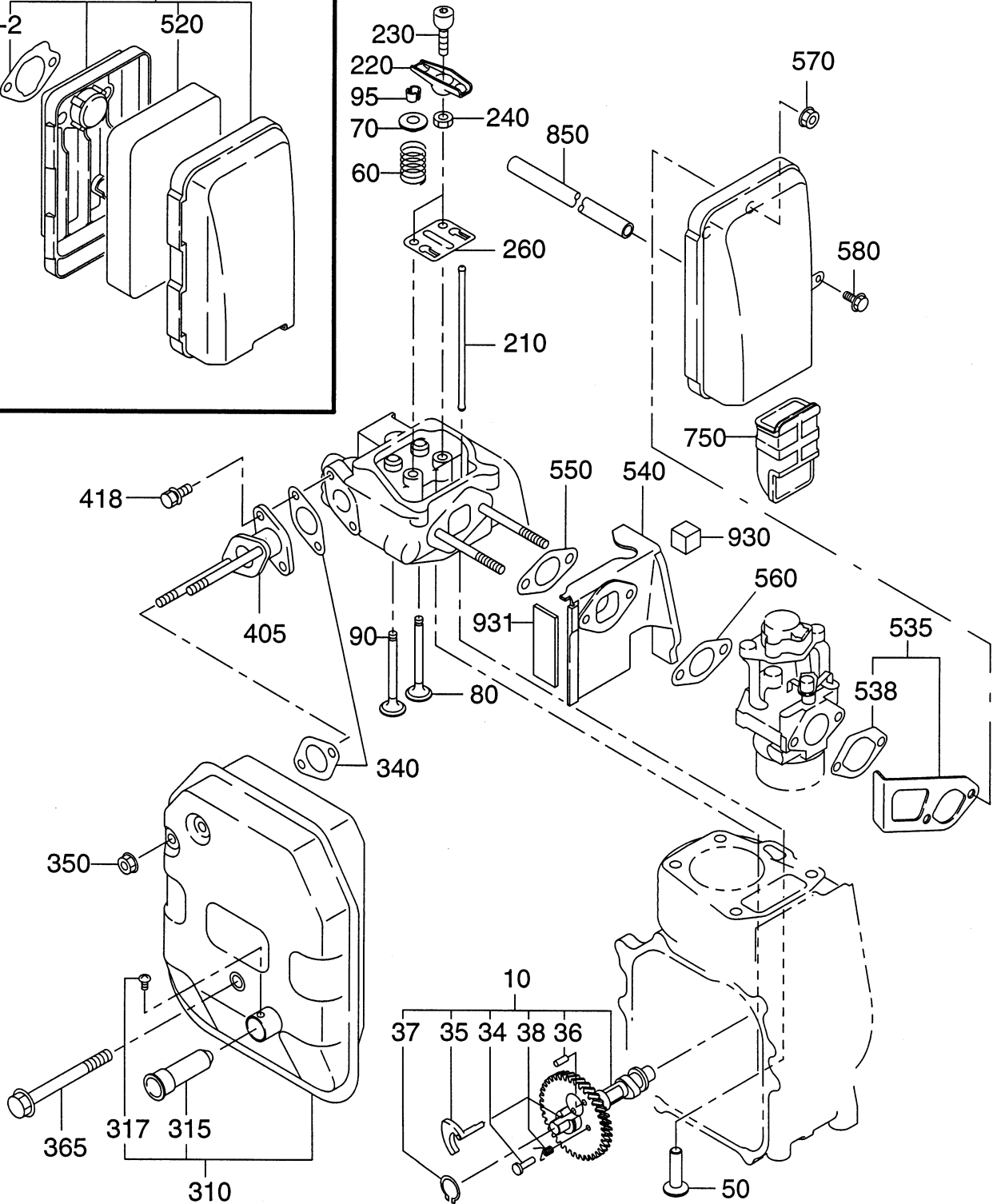
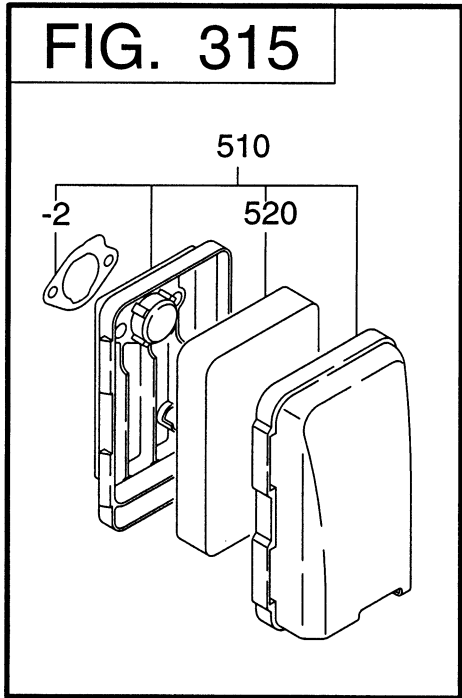
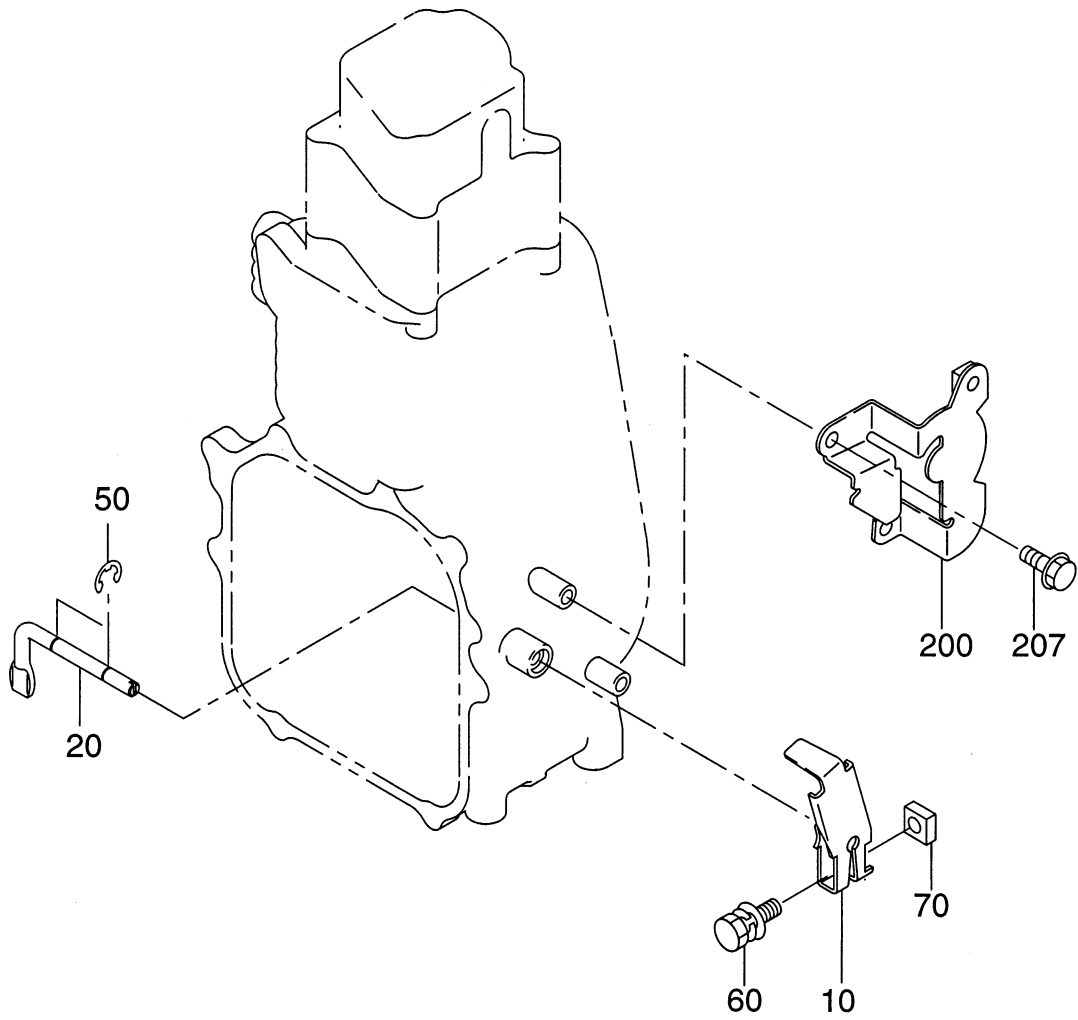

FIG. 400



4 GOVERNOR OPERATION

REF.	PART NUMBER	PART NAME	QTY	REMARKS	CODE NO. FROM-TO	INTERCHANGEABLE PART NUMBER	UNIT PRICE	FIG.
10	284-42305-03	GOVERNOR LEVER	1		-			400
20	230-42201-01	GOVERNOR SHAFT CP	1		-			400
50	003-13050-00	CLIP	2		-			400
60	001-14062-50	BOLT AND WASHER AY	1		-			400
70	018-60600-20	NUT	1	M6X1.0X4.9H SQUARE	-			400
200	284-46003-03	CONTROL BRACKET	1		-			400
207	011-00600-10	FLANGE BOLT	2	M6X1.0X14DX8L	-			400

FIG. 500

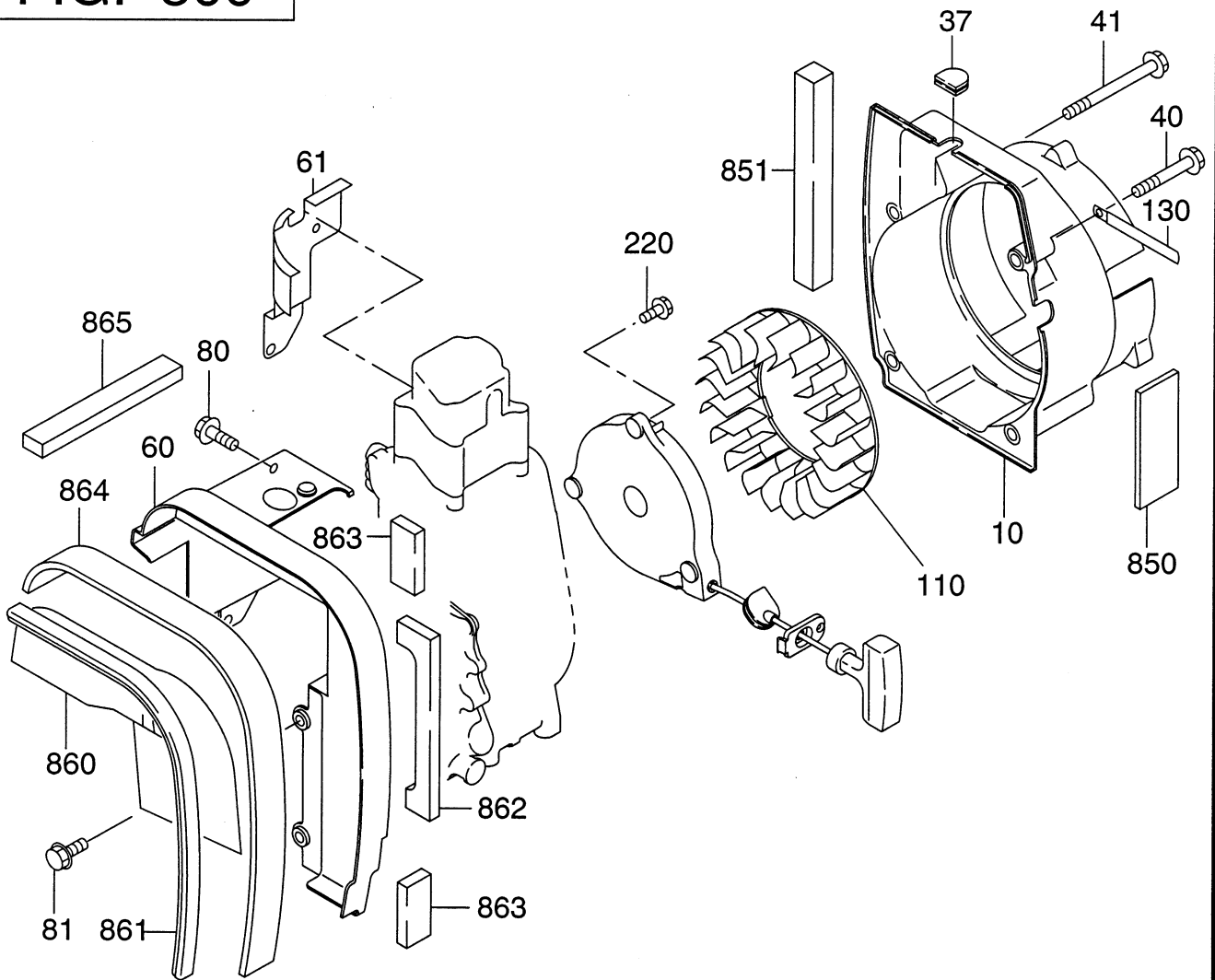
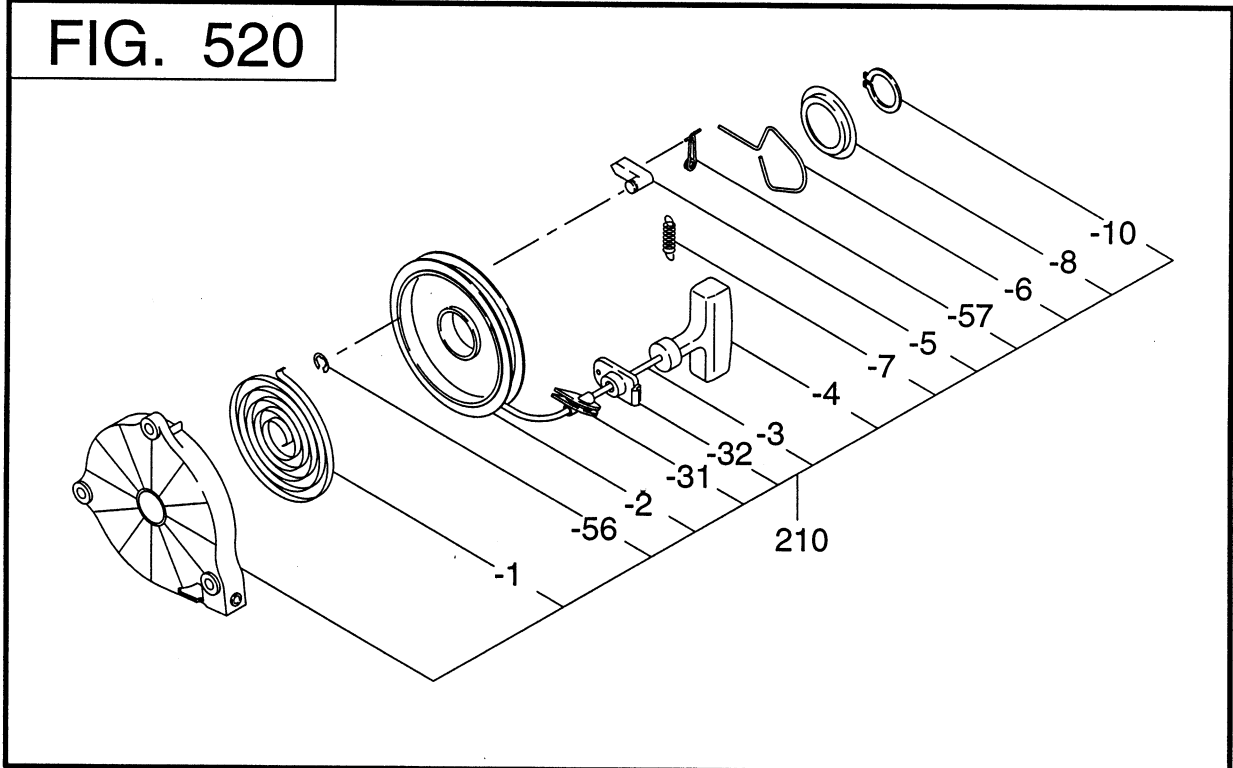

FIG. 520



5 COOLING STARTING

REF.	PART NUMBER	PART NAME	QTY	REMARKS	CODE NO. FROM-TO	INTERCHANGEABLE PART NUMBER	UNIT PRICE	FIG.
10	284-51201-03	BLOWER HOUSING	1		-			500
37	284-55501-03	GROMMET	1		-			500
40	011-00801-60	FLANGE BOLT	1	M8X55L	-			500
41	011-00803-02	FLANGE BOLT	3		-			500
60	284-53601-01	CYLINDER BAFFLE CP	1		-			500
61	284-53603-03	CYLINDER BAFFLE (E/G)	1		-			500
80	011-00801-50	FLANGE BOLT	3	M8X1.25X16DX12L	-			500
81	011-00600-20	FLANGE BOLT	1	M6X1.0X14DX12L	-			500
110	284-54201-13	COOLING FAN	1		-			500
130	056-60002-60	CLAMP	1	8.5DX10BX95LX0.4T	-			500
210	284-50221-10	RECOIL AY	1		-			520
- 1	284-50224-08	SPIRAL SPRING	1		-			520
- 2	284-50222-08	REEL	1		-			520
- 3	284-50233-08	STARTER ROPE	1		-			520
- 4	530-50021-10	STARTER KNOB	1		-			520
- 5	284-50223-08	RACHET	1		-			520
- 6	284-50226-08	FRICITION SPRING	1		-			520
- 7	284-50227-08	RETURN SPRING	1		-			520
- 8	284-50225-18	FRICITION PLATE	1		-			520
- 10	284-50231-08	RETAINING RING C TY	1		-			520
- 31	284-56101-03	ROPE GUIDE	1		-			520
- 32	33K-53001-03	GUIDE COMP	1		-			520
- 56	284-50229-08	RETAINING RING E TYP	1		-			520
- 57	284-50228-08	RACHET GUIDE	1		-			520
220	011-00601-40	FLANGE BOLT	3	M6X1.0X14DX18L	-			500
850	34K-40102-03	SEAL PLATE	2		-			500
851	284-51203-03	SEAL SPONGE BL	1		-			500
860	284-53606-13	INSULATION SEAT B1	1		-			500
861	284-53605-03	SEAL RUBBER	1		-			500
862	284-53609-03	SEAL SPONGE BAFFLE 2	1		-			500
863	284-53610-03	SEAL SPONGE BAFFLE 3	2		-			500
864	33K-58323-03	SPONGE BAFFLE 4	1		-			500
865	284-53608-03	SEAL SPONGE BAFFLE	1		-			500

FIG. 600

FIG. 640

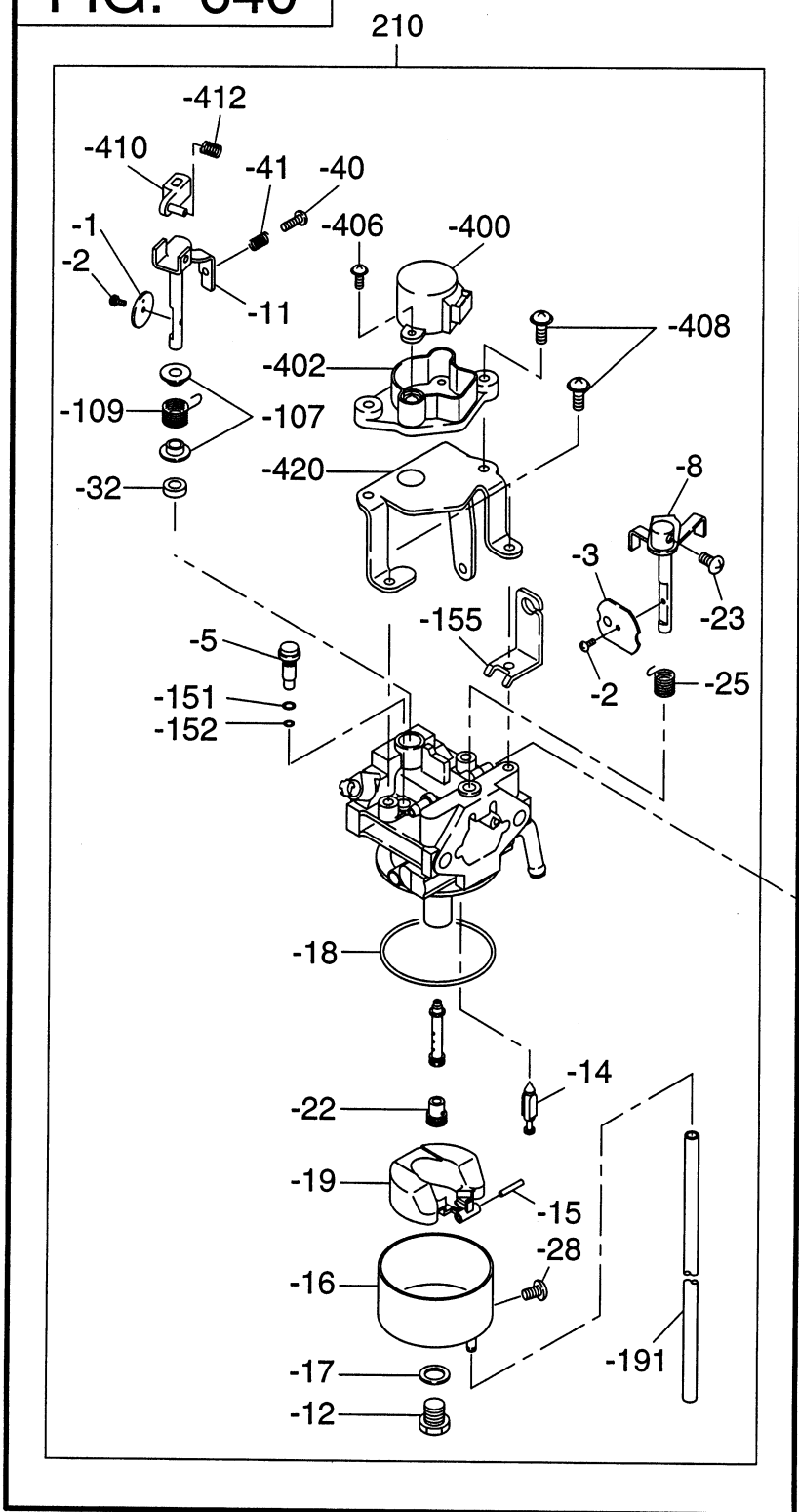

6 FUEL LUBRICANT

REF.	PART NUMBER	PART NAME	QTY	REMARKS	CODE NO. FROM-TO	INTERCHANGEABLE PART NUMBER	UNIT PRICE	FIG.
210	284-62302-20	CARBURETOR AY	1		-			640
- 1	284-62535-08	THROTTLE VALVE	1		-			640
- 2	284-62455-08	SCREW	2		-			640
- 3	284-62525-08	VALVE CHOKE	1		-			640
- 5	284-62420-08	SLOW JET	1		-			640
- 8	284-62520-08	SHAFT AY CHOKE	1		-			640
- 11	284-62531-08	SHAFT AY, THROTTLE	1		-			640
- 12	284-62355-08	SCREW	1		-			640
- 14	279-62500-08	VALVE ASSY NEEDLE	1		-			640
- 15	284-62515-08	PIN, FLOAT LEVER	1		-			640
- 16	284-62550-08	CHAMBER AY, FLOAT	1		-			640
- 17	251-62350-08	GASKET	1		-			640
- 18	284-62540-08	GASKET CHAMBER	1		-			640
- 19	284-62505-08	FLOAT AY	1		-			640
- 22	284-62400-08	MAIN JET	1		-			640
- 23	284-62456-08	SCREW	1		-			640
- 25	284-62445-08	SPRING CHOKE	1		-			640
- 28	251-62661-08	DRAIN SCREW	1		-			640
- 32	251-62559-08	BUSH	1		-			640
- 40	284-62353-08	SCREW ADJUST	1		-			640
- 41	279-62445-08	SPRING	1		-			640
-107	284-62561-08	COLLAR	2		-			640
-109	284-62315-08	SPRING THROTTLE	1		-			640
-151	284-62451-08	O-RING	1		-			640
-152	284-62450-08	O-RING	1		-			640
-155	284-62570-18	BRACKET WIRE	1		-			640
-191	284-62566-18	PIPE	1		-			640
-400	284-62580-08	MOTOR	1		-			640
-402	284-62576-08	BRACKET MOTOR	1		-			640
-406	284-62458-08	SCREW	2		-			640
-408	284-62457-08	SCREW	5		-			640
-410	284-62555-08	JOINT LEVER	1		-			640
-412	284-62446-08	SPRING	1		-			640
-420	284-62575-08	BRACKET	1		-			640
220	085-09300-00	VINYL PIPE	1		-			600
221	085-09300-00	VINYL PIPE	1		-			600

FIG. 600

FIG. 640

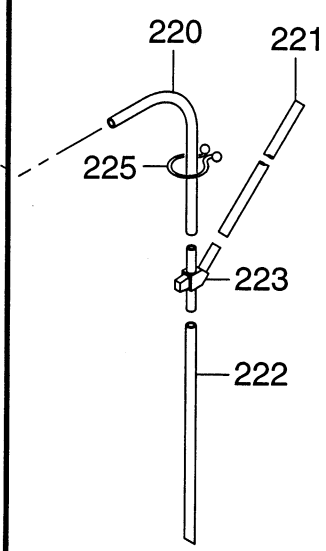
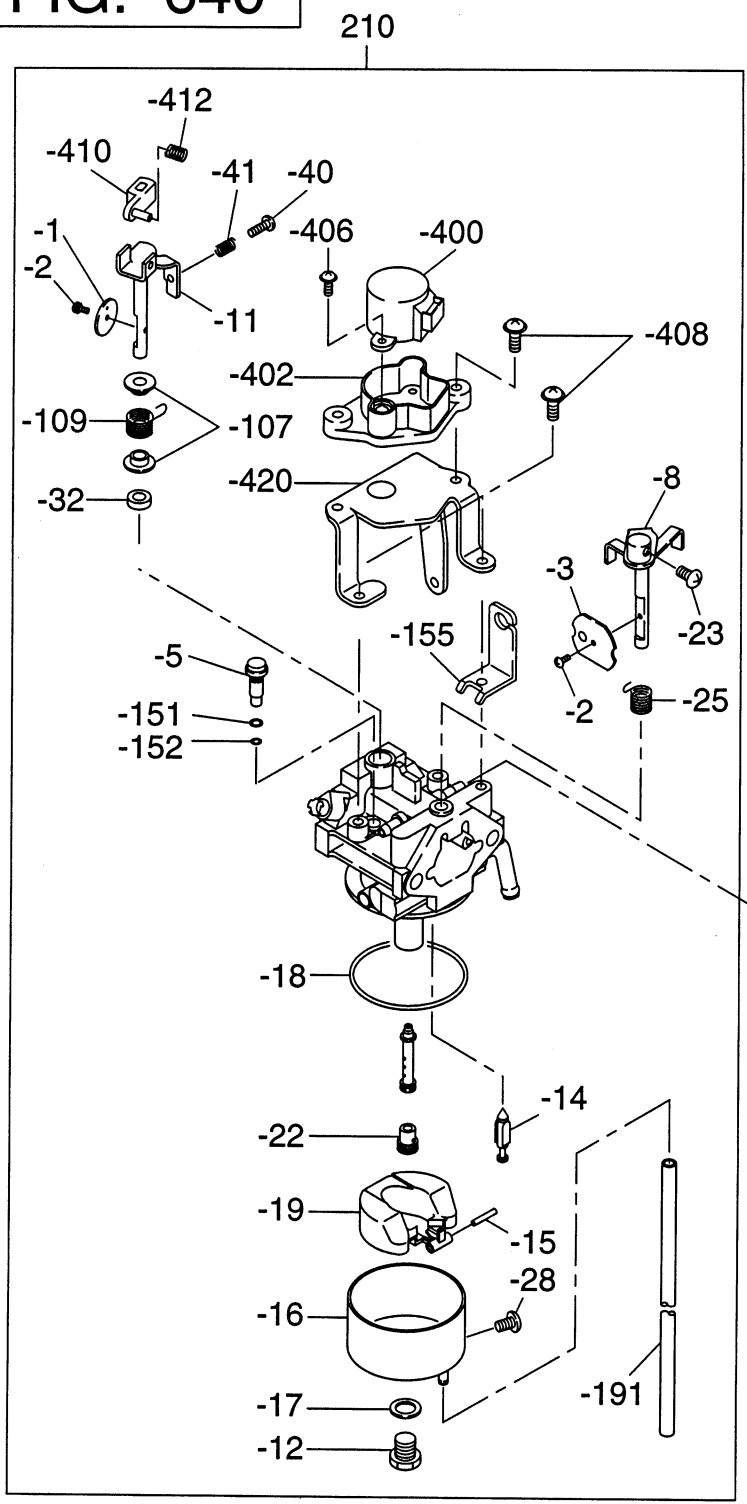

FIG. 700

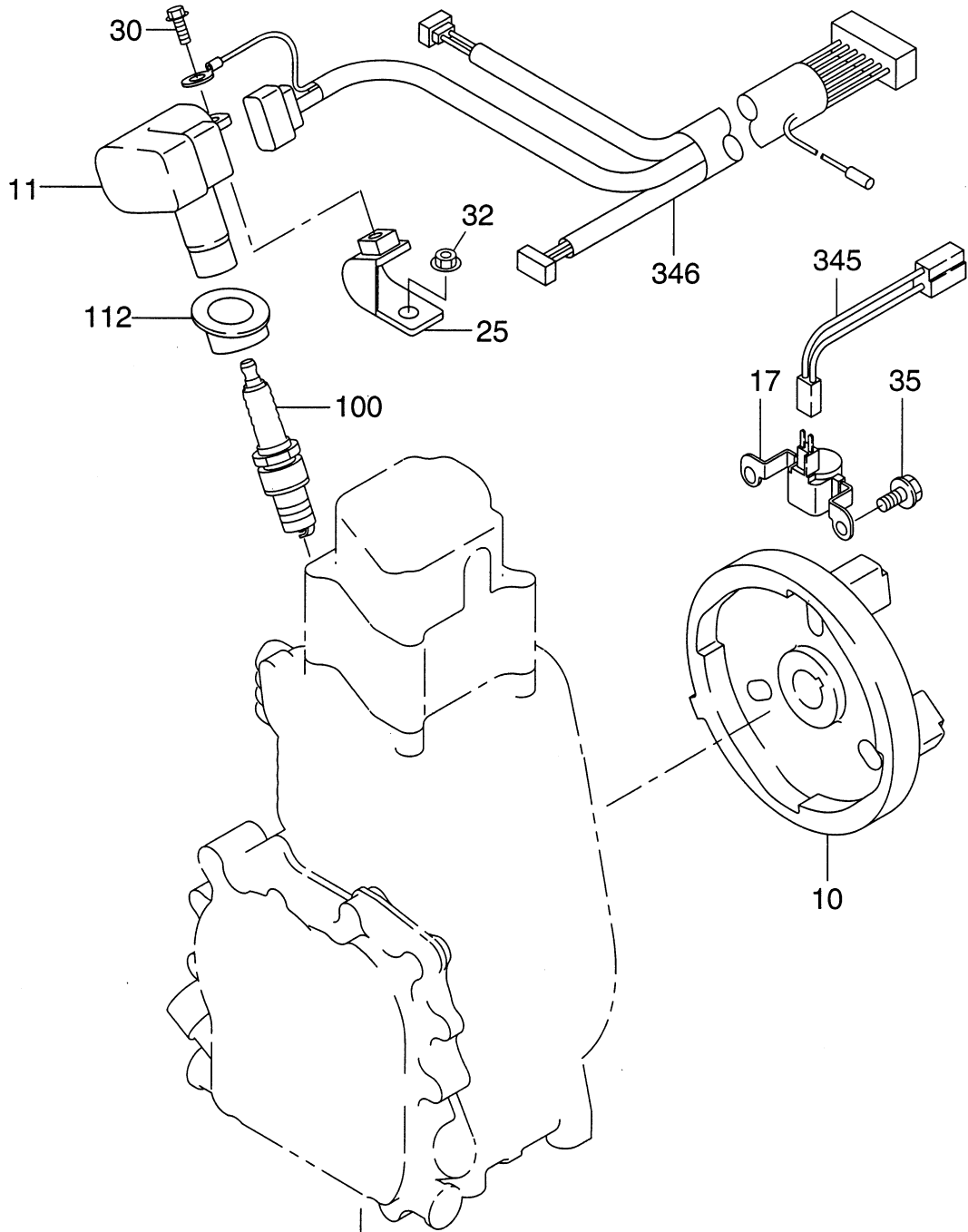

FIG. 770

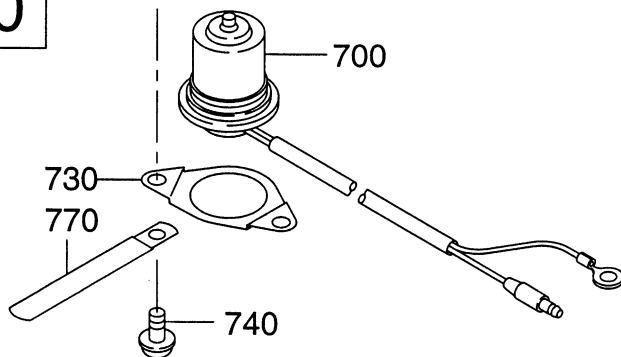

FIG. 2200

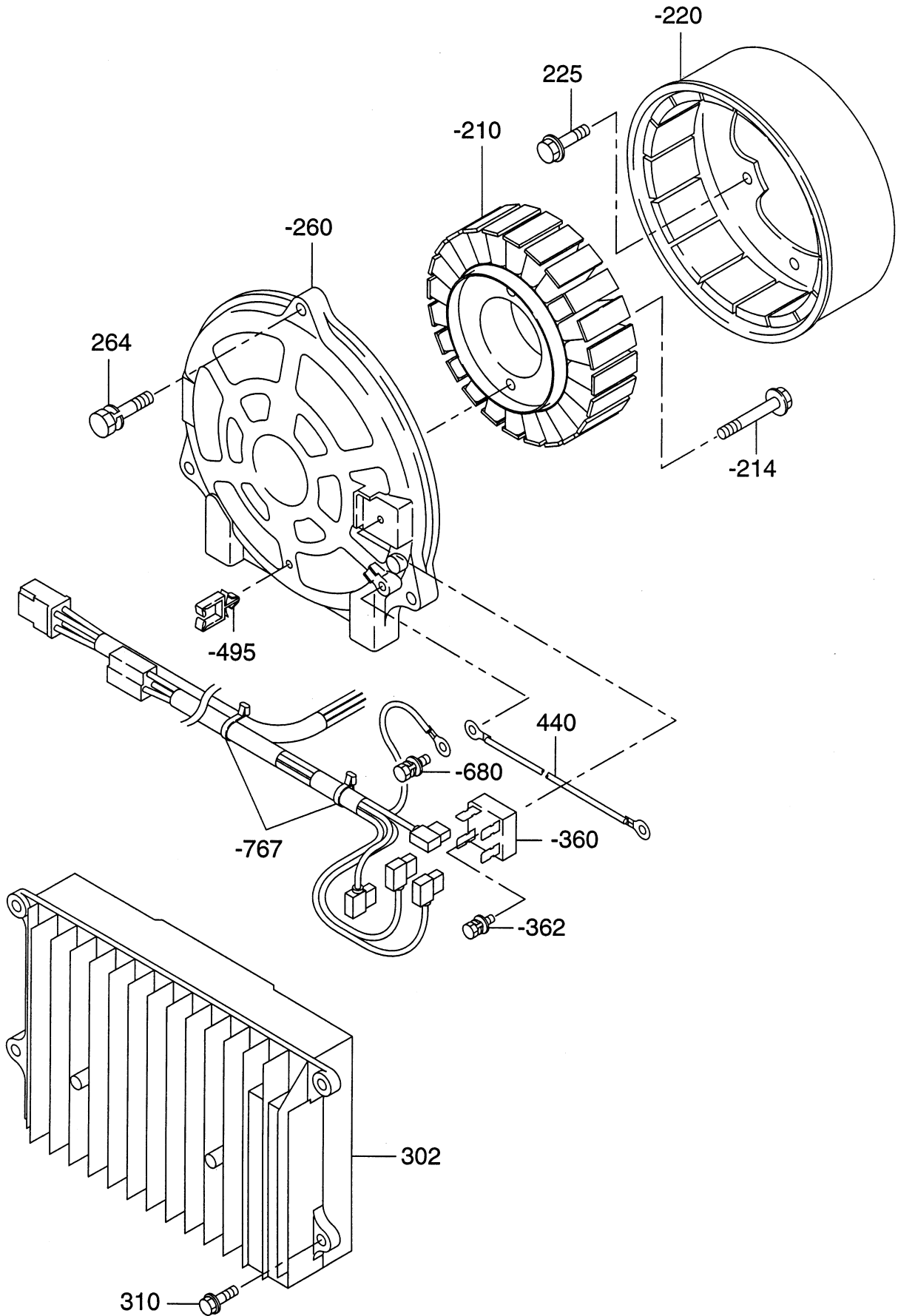
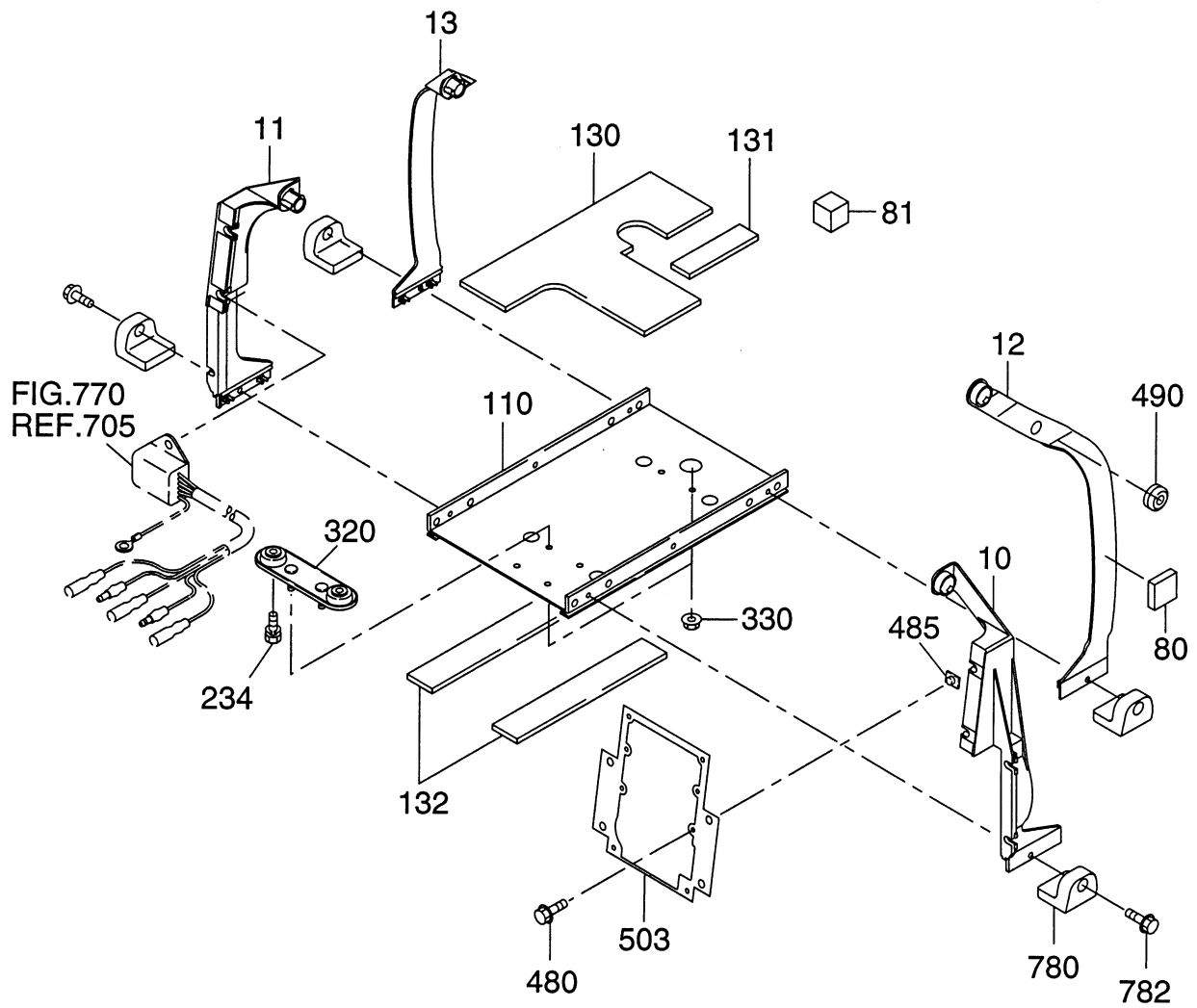

FIG. 2300



2 3 BASE, FRAME

REF.	PART NUMBER	PART NAME	QTY	REMARKS	CODE NO. FROM-TO	INTERCHANGEABLE PART NUMBER	UNIT PRICE	FIG.
10	33K-37101-03	FRONT FRAME(R)	1		-			2300
11	33K-37201-03	FRONT FRAME(L)	1		-			2300
12	33K-37301-03	REAR FRAME(R)	1		-			2300
13	33K-37401-03	REAR FRAME(L)	1		-			2300
80	33K-58413-03	SPONGE R-FRAME	1		-			2300
81	33K-58414-03	SPONGE R-FRAME 2	2		-			2300
110	34K-30601-23	BASE(INV)	1		-			2300
130	33K-58310-03	SPONGE BASE	1		-			2300
131	33K-58311-03	SPONGE BASE 2	1		-			2300
132	33K-58320-03	SPONGE BASE 3	2		-			2300
234	001-14082-00	BOLT AND WASHER AY	4		-			2300
320	33K-30101-01	MOUNT BASE CP	2		-			2300
330	002-38060-00	FLANGE NUT	4		-			2300
480	011-00600-20	FLANGE BOLT	4	M6X1.0X14DX12L	-			2300
485	33K-38001-03	NUT	8		-			2300
490	33K-38005-03	GROMMET (R-FRAME)	2		-			2300
503	33K-37601-03	BACK PANEL CP	1		-			2300
780	33K-36101-01	MOUNT CP	4		-			2300
782	011-00601-80	FLANGE BOLT	4	M6X1.0X14DX18L	-			2300

FIG. 2400

50Hz 230V GBR

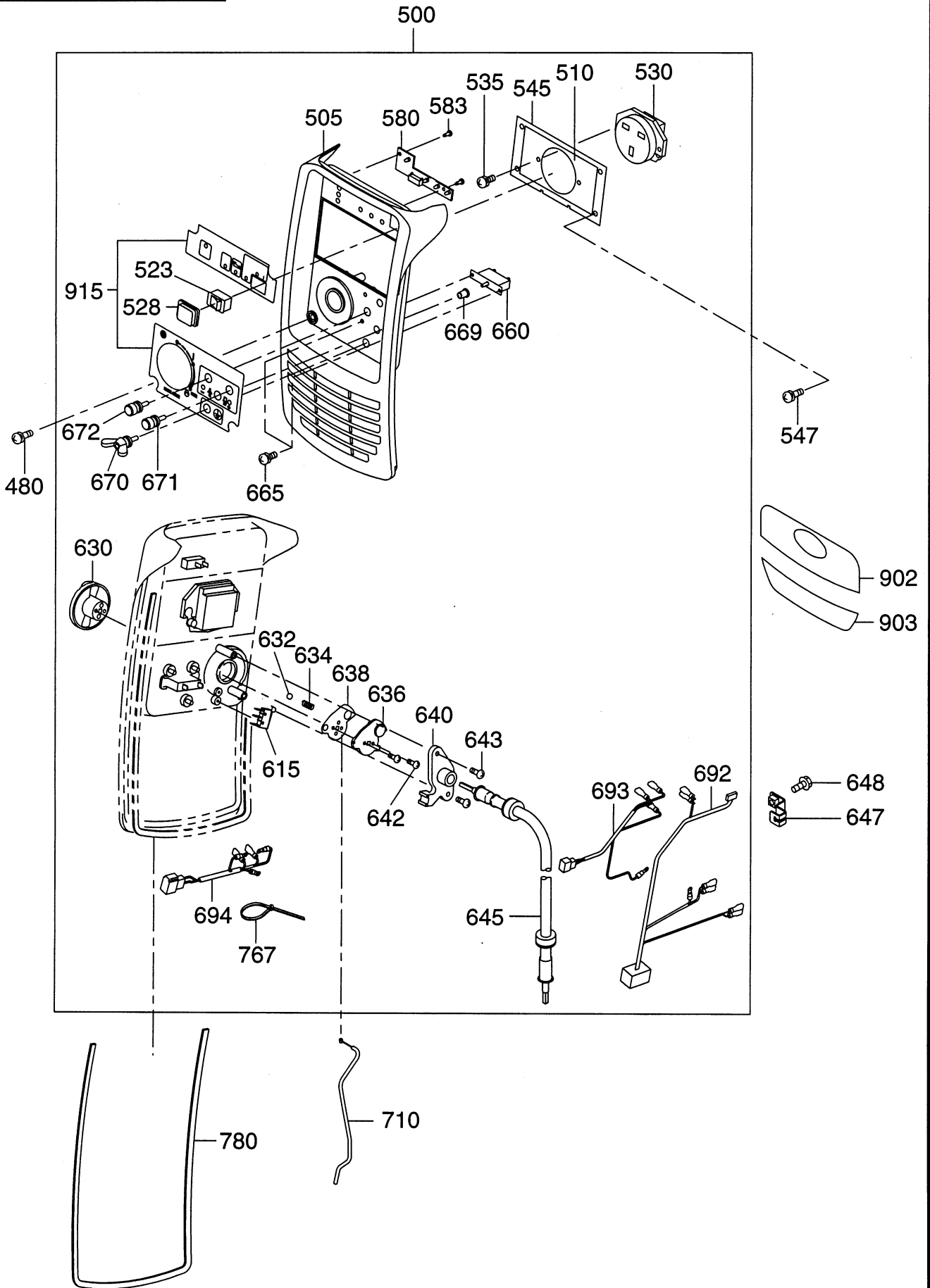

2 4 CONTROL

REF.	PART NUMBER	PART NAME	QTY	REMARKS	CODE NO. FROM-TO	INTERCHANGEABLE PART NUMBER	UNIT PRICE	FIG.
480	014-00501-00	SCREW	4		-			2400
500	34K-40041-40	CONTROL PANEL AY	1		-			2400
505	33K-40101-03	FRONT PANEL	1		-			2400
510	33K-41903-13	FILM	1		-			2400
523	34K-41812-03	ROCKER SWITCH	1		-			2400
528	34K-41813-03	SWITCH COVER	1		-			2400
530	358-40616-08	AC CONCENT (ENGLAND)	1		-			2400
535	33K-41828-08	SCREW AND WASHER AY	2		-			2400
545	33K-40802-13	CONSENT BRACKET	1		-			2400
547	013-10400-60	SCREW AND WASHER AY	4		-			2400
580	KD3-11001-01	LED INDICATOR CP	1		-			2400
583	015-00300-20	TAPPING SCREW	2		-			2400
615	33K-41811-03	MICRO SWITCH	1		-			2400
630	33K-42010-03	CONTROL DIAL	1		-			2400
632	33K-42071-03	BALL(DIAL)	1		-			2400
634	33K-42074-03	SPRING(DIAL)	1		-			2400
636	33K-42020-03	CHOKE REEL	1		-			2400
638	33K-42030-13	PLATE	1		-			2400
640	33K-42040-03	WIRE PLATE	1		-			2400
642	015-00400-70	TAPPING SCREW	2		-			2400
643	33K-41814-08	TAPPING SCREW	2		-			2400
645	33K-42050-11	ROLLING WIRE CP	1		-			2400
647	33K-42080-03	CHOKE BRACKET	1		-			2400
648	011-00600-10	FLANGE BOLT	1	M6X1.0X14DX8L	-			2400
660	352-45620-08	CIRCUIT BREAKER	1		-			2400
665	013-10300-10	SCREW AND WASHER AY	2		-			2400
669	33K-41817-03	BREAKER CAP	1		-			2400
670	33K-42090-01	TERMINAL BOLT	1		-			2400
671	363-45701-08	TERMINAL BOLT	1	RED 20A	-			2400
672	363-45700-08	TERMINAL BOLT	1	BLACK 20A	-			2400
692	34K-41817-13	PANEL HARNESS	1		-			2400
693	34K-41819-13	CONCENT HARNESS	1		-			2400
694	34K-41816-13	DC OUT HARNESS	1		-			2400
710	33K-42060-21	CHOKE WIRE CP	1		-			2400
767	056-30000-20	WIRE BAND	1	2.5BX1.2TX100L	-			2400
780	33K-58411-03	SEAL SPONGE F	1		-			2400

FIG. 2400

50Hz 230V GBR

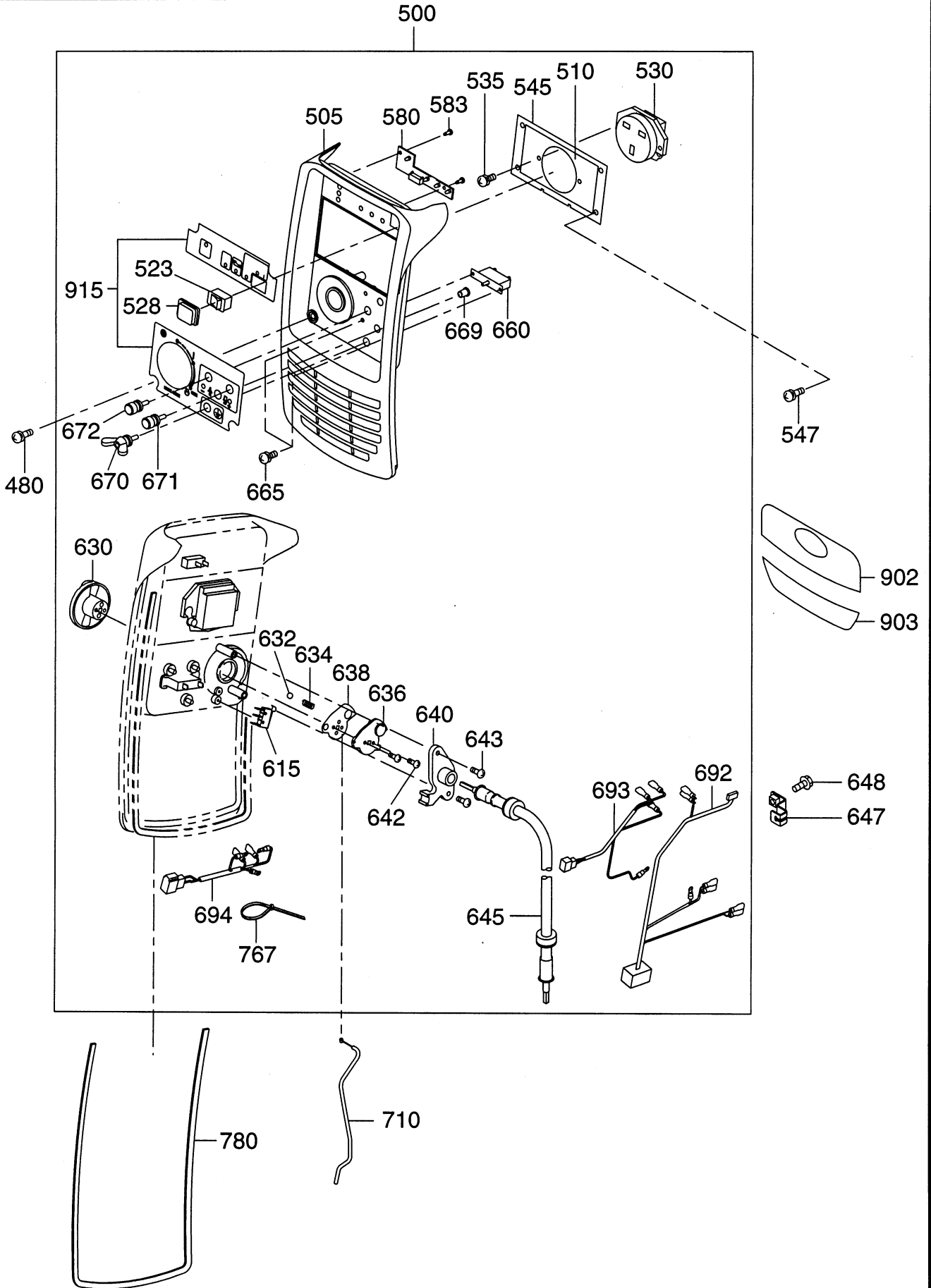

2 4 CONTROL

REF.	PART NUMBER	PART NAME	QTY	REMARKS	CODE NO. FROM-TO	INTERCHANGEABLE PART NUMBER	UNIT PRICE	FIG.
902	34K-49511-03	LABEL(FRONT) INV	1		-			2400
903	34K-95101-03	LABEL(FRONT) 2	1		-			2400
915	34K-41853-03	FILM INV	1		-			2400

FIG. 2500

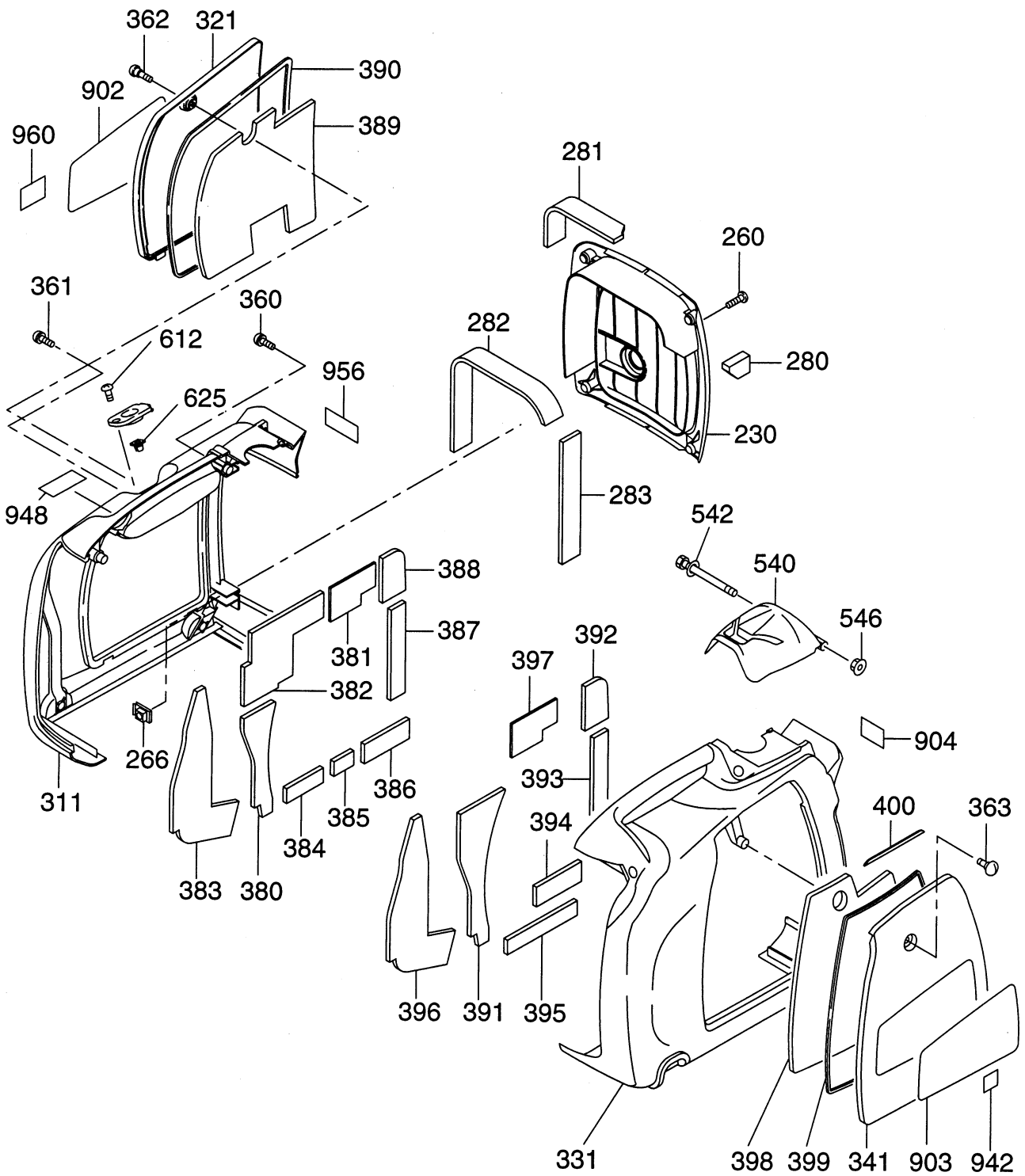

2 5 COVER

REF.	PART NUMBER	PART NAME	QTY	REMARKS	CODE NO. FROM-TO	INTERCHANGEABLE PART NUMBER	UNIT PRICE	FIG.
230	33K-50201-03	REAR COVER	1		-			2500
260	013-10600-30	SCREW AND WASHER AY	4		-			2500
266	33K-50205-01	NUT CP	4		-			2500
280	33K-58318-13	R-COVER SPONGE 1	2		-			2500
281	33K-58319-13	R-COVER SPONGE 2	1		-			2500
282	33K-58322-03	R-COVER SPONGE 3	1		-			2500
283	33K-58324-03	R-COVER SPONGE 4	1		-			2500
311	33K-50301-13	CASE BODY L	1		-			2500
321	33K-50311-03	SIDE PANEL L	1		-			2500
331	33K-50401-13	CASE BODY R	1		-			2500
341	33K-50411-03	SIDE PANEL R	1		-			2500
360	004-36062-50	SCREW AND WASHER AY	2		-	004-35062-50		2500
361	004-36062-00	SCREW AND WASHER AY	1		-	004-35062-00		2500
362	33K-50501-03	BOLT (PANEL)	1		-			2500
363	33K-50501-03	BOLT (PANEL)	1		-			2500
380	33K-58301-03	SPONGE CASE L	1		-			2500
381	33K-58307-03	SPONGE CASE L 5	1		-			2500
382	33K-58305-03	SPONGE CASE L 3	1		-			2500
383	33K-58304-03	SPONGE CASE L 2	1		-			2500
384	33K-58308-03	SPONGE CASE L 6	1		-			2500
385	33K-58309-03	SPONGE CASE L 7	1		-			2500
386	33K-58408-03	SPONGE CASE R 6	1		-			2500
387	33K-58409-03	SPONGE CASE R 7	1		-			2500
388	33K-58306-03	SPONGE CASE L 4	1		-			2500
389	33K-58302-03	SPONGE PANEL L	1		-			2500
390	33K-58303-03	SEAL SPONGE L	1		-			2500
391	33K-58401-03	SPONGE CASE R	1		-			2500
392	33K-58406-03	SPONGE CASE R 4	1		-			2500
393	33K-58409-03	SPONGE CASE R 7	1		-			2500
394	33K-58408-03	SPONGE CASE R 6	1		-			2500
395	33K-58407-03	SPONGE CASE R 5	1		-			2500
396	33K-58404-03	SPONGE CASE R 2	1		-			2500
397	33K-58405-03	SPONGE CASE R 3	1		-			2500
398	33K-58402-03	SPONGE PANEL R	1		-			2500
399	33K-58403-03	SEAL SPONGE R	1		-			2500
400	33K-58410-03	SEAL SPONGE R 2	1		-			2500

FIG. 2500

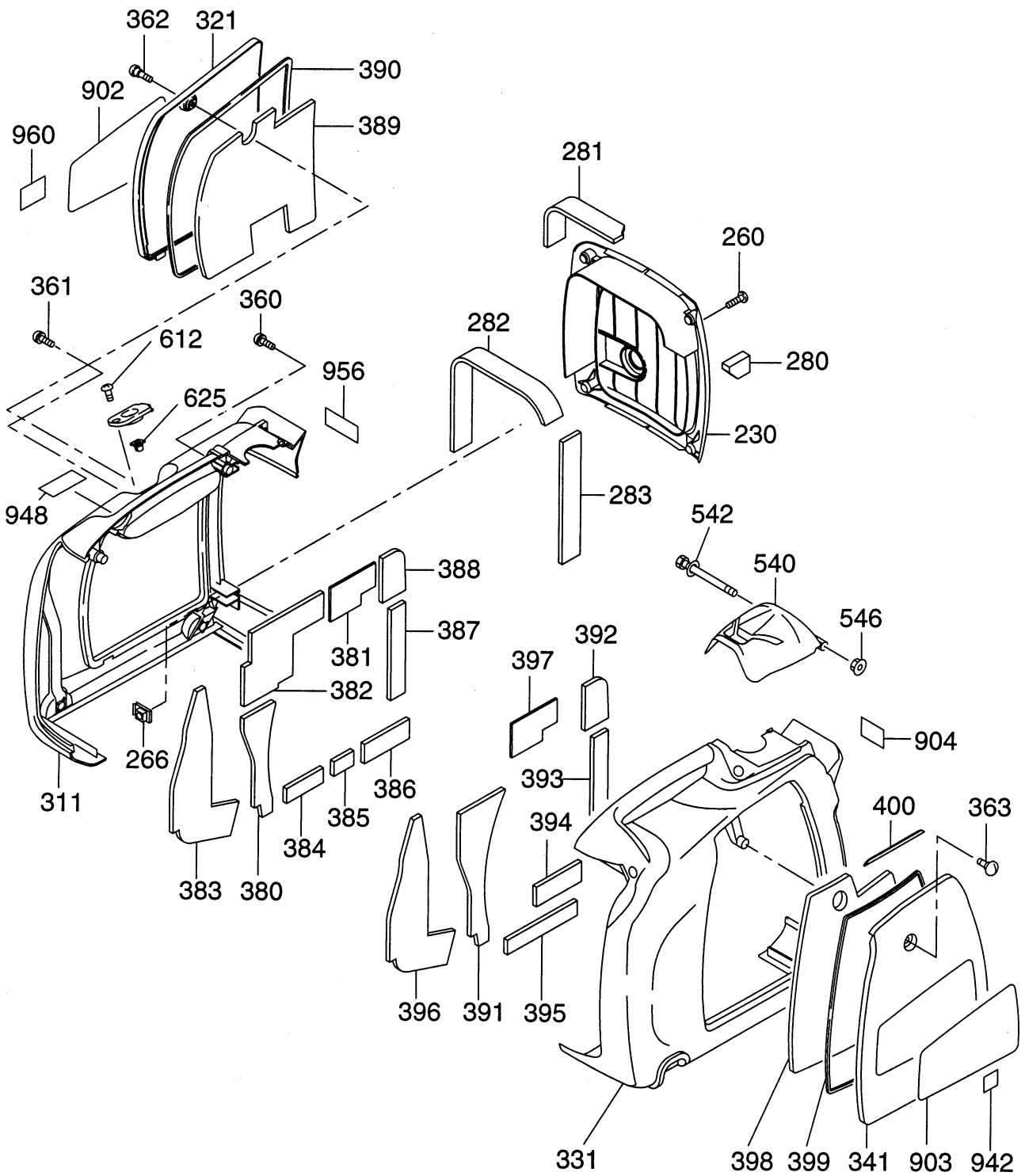

2 5 COVER

REF.	PART NUMBER	PART NAME	QTY	REMARKS	CODE NO. FROM-TO	INTERCHANGEABLE PART NUMBER	UNIT PRICE	FIG.
540	33K-55001-13	TANK CAP COVER	1		-			2500
542	013-10400-91	SCREW AND WASHER AY	1		-			2500
546	018-00400-00	FLANGE NUT	1		-			2500
612	015-00400-90	TAPPING SCREW	1	M4X10L	-			2500
625	33K-53002-03	SCREW GROMMET	1		-			2500
902	34K-91202-13	LABEL(MODEL)L	1		-			2500
903	34K-91201-13	LABEL(MODEL)R	1		-			2500
904	34K-91607-13	LABEL SPEC	1		-			2500
942	073-20045-20	LABEL(OIL CAUTION)	1	37X37 ILLUSTR	-			2500
948	073-20045-10	LABEL(SYMBOL-TANK)	1	50X71	-			2500
956	073-20045-00	LABEL (HOT&GAS)	1		-			2500
960	073-20053-70	LABEL(91DB)	1		-			2500

FIG. 2600

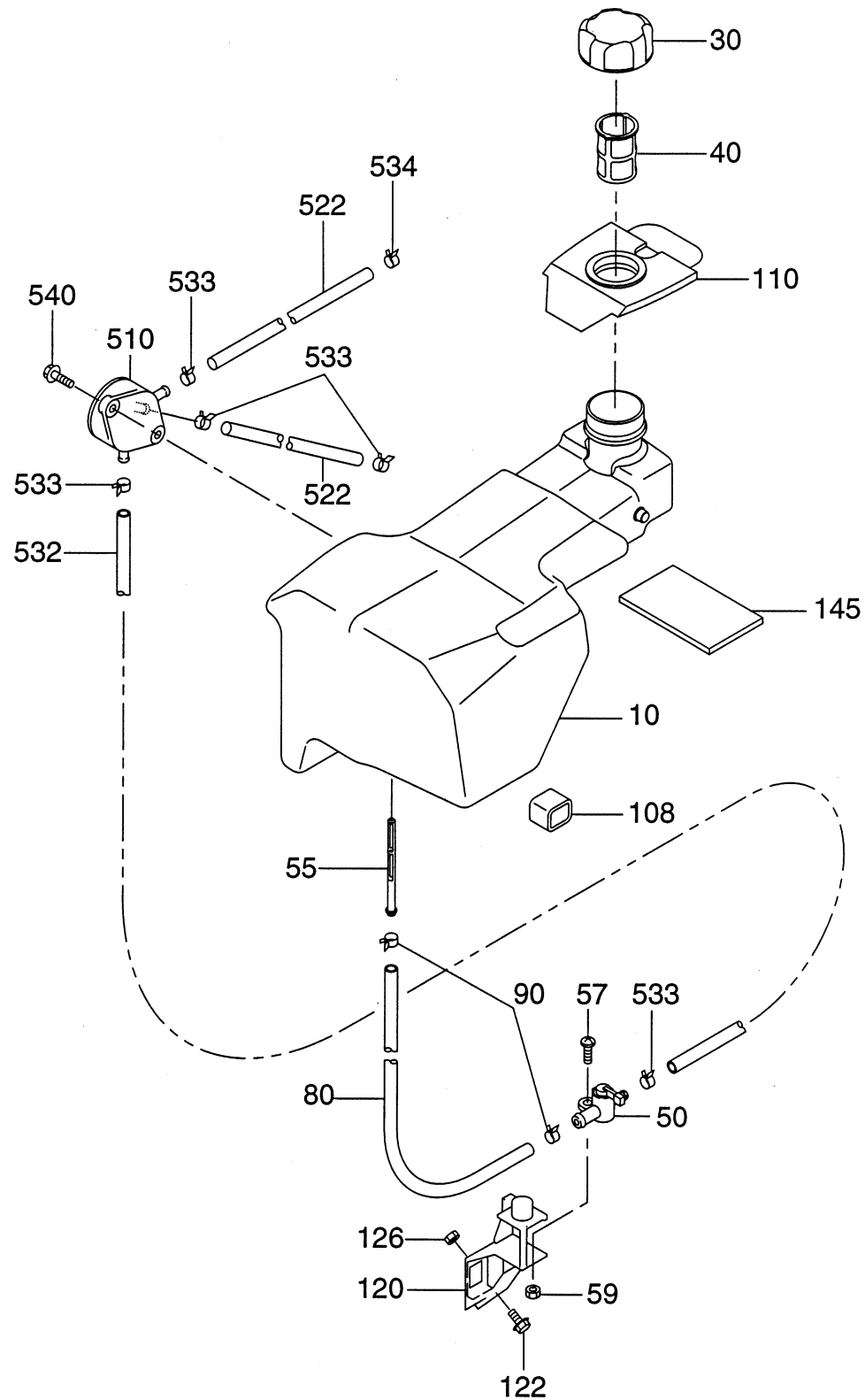

26 FUEL TANK

REF.	PART NUMBER	PART NAME	QTY	REMARKS	CODE NO. FROM-TO	INTERCHANGEABLE PART NUMBER	UNIT PRICE	FIG.
10	33K-61101-12	FUEL TANK UN	1		-			2600
30	33K-65001-01	FUEL TANK CAP CP	1		-			2600
40	33K-61201-J1	FUEL FILTER CP	1		-			2600
50	33K-63001-10	FUEL COCK AY	1		-			2600
55	33K-61401-01	FUEL STRAINER	1		-			2600
57	004-36051-20	SCREW AND WASHER AY	1		-			2600
59	002-18050-00	NUT	1		-			2600
80	33K-62250-03	RUBBER PIPE	1		-			2600
90	056-11300-10	HOSE CLAMP	2		-			2600
108	33K-64101-03	TANK MOUNT	2		-			2600
110	33K-64001-13	NECK RUBBER	1		-			2600
120	33K-63002-03	FUELCOCK BRACKET	1		-			2600
122	011-00600-30	FLANGE BOLT	1	M6X1.0X14DX14L	-			2600
126	002-17060-00	NUT	1		-			2600
145	33K-58412-13	TANK SPONGE	1		-			2600
510	33K-62201-00	FUEL PUMP CP	1		-			2600
522	085-10600-00	RUBBER PIPE	2	6DX12D	-			2600
532	085-10600-00	RUBBER PIPE	1	6DX12D	-			2600
533	056-11100-20	HOSE CLAMP	5	11.5DX8BX0.7T	-			2600
534	056-11000-30	HOSE CLAMP	1	10DX8BX1T	-			2600
540	015-00600-20	TAPPING SCREW	2		-			2600

FIG. 2900

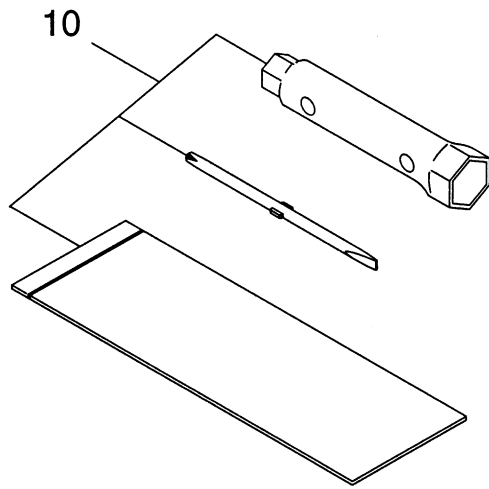

29 ACCESSORIES

REF.	PART NUMBER	PART NAME	QTY	REMARKS	CODE NO. FROM-TO	INTERCHANGEABLE PART NUMBER	UNIT PRICE	FIG.
10	33K-99001-00	ACCESSORY TOOL KIT	1		-			2900