



**Robin Generator**

**Model      RG3200iS**

**For USA**

**PARTS CATALOG**

**Spec. No. RAS32023510**  
**(E/G Spec. No. EX210DS2040)**

**富士重工業株式会社**  
**FUJI HEAVY INDUSTRIES LTD.**

<b>ISSUE EMD-GP6024</b>	
<b>ISSUE DATE</b>	<b>2004.05</b>



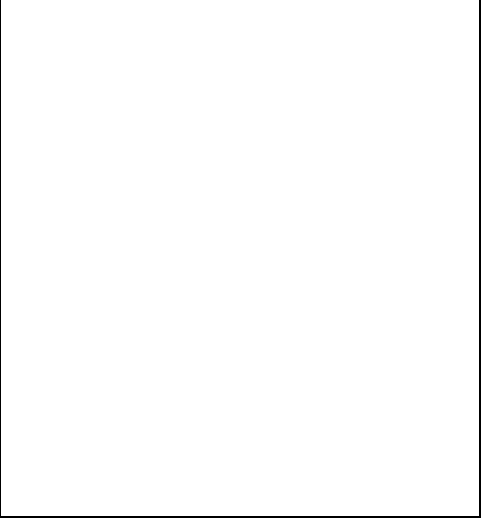
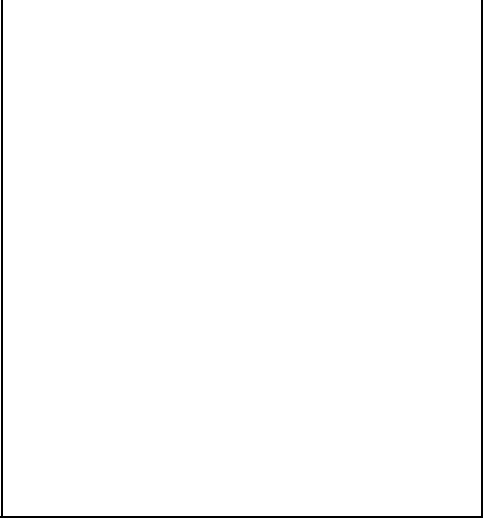
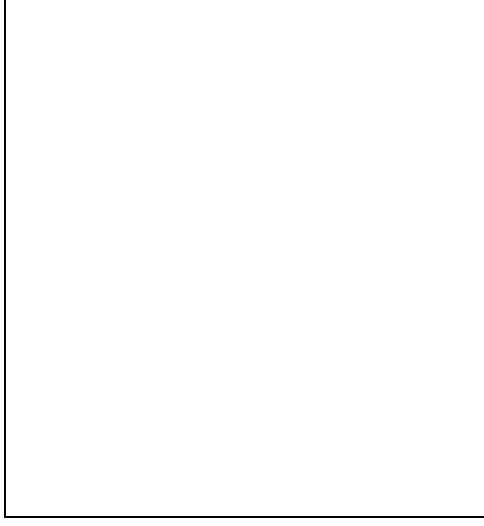
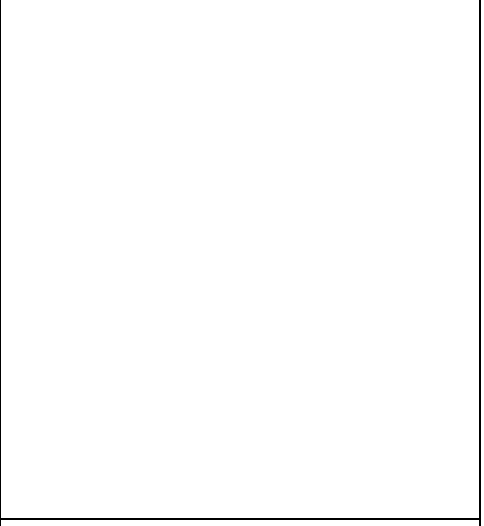
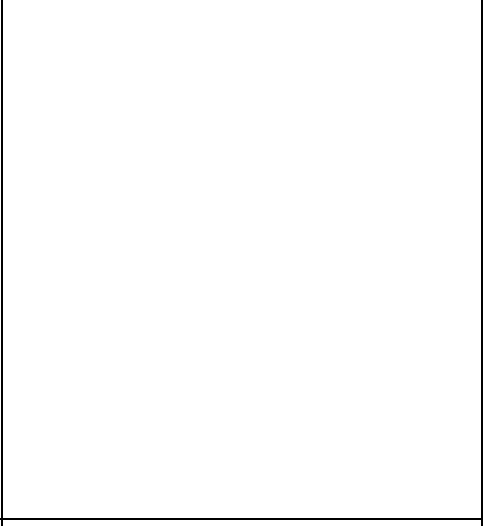
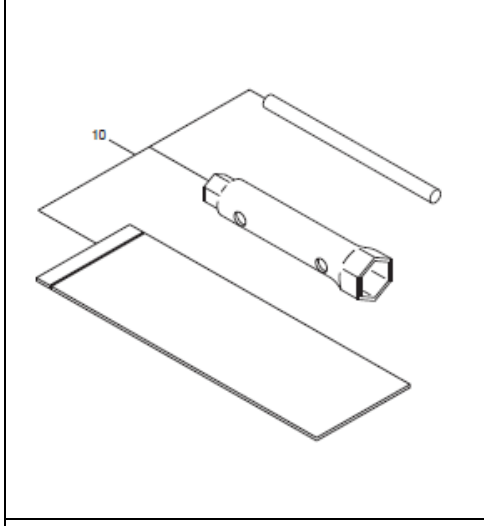
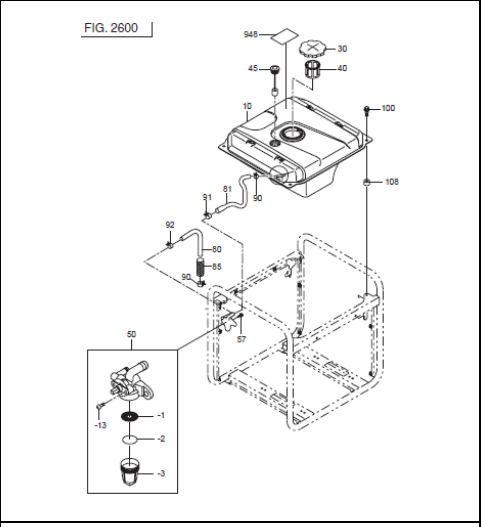
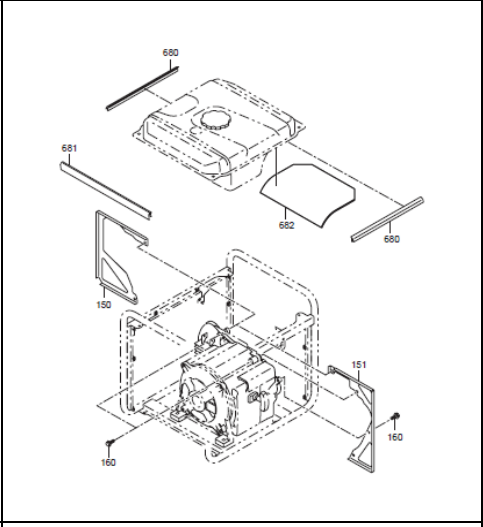
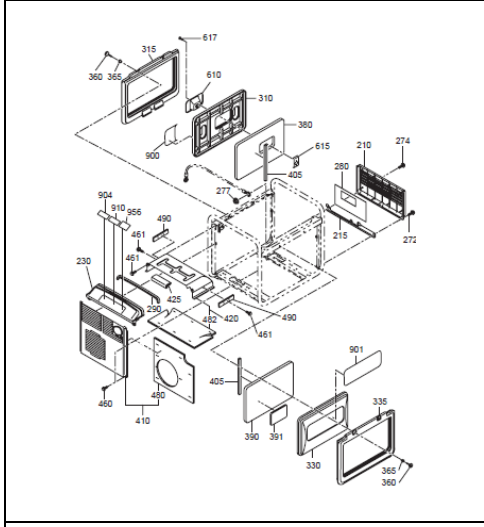
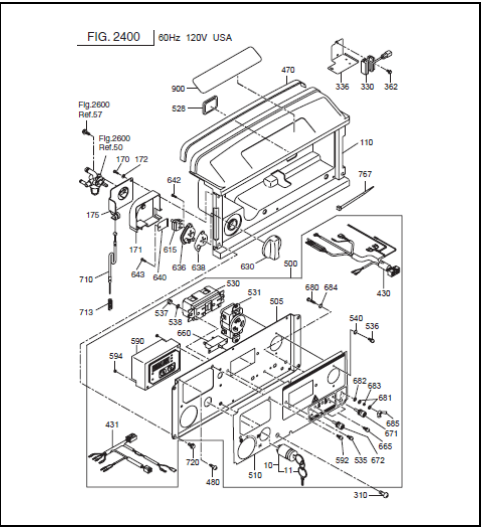
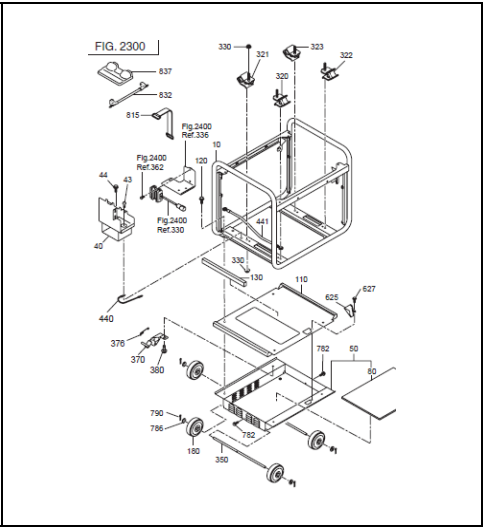
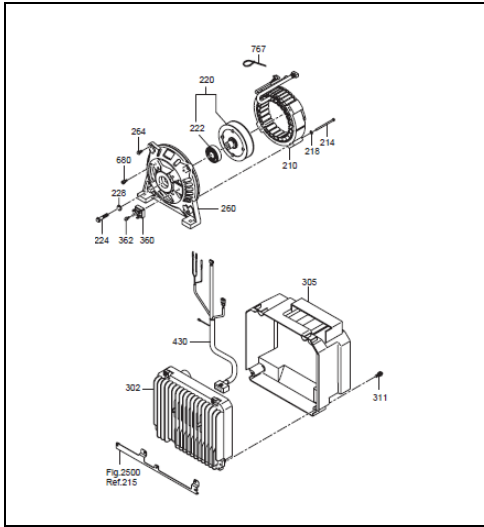
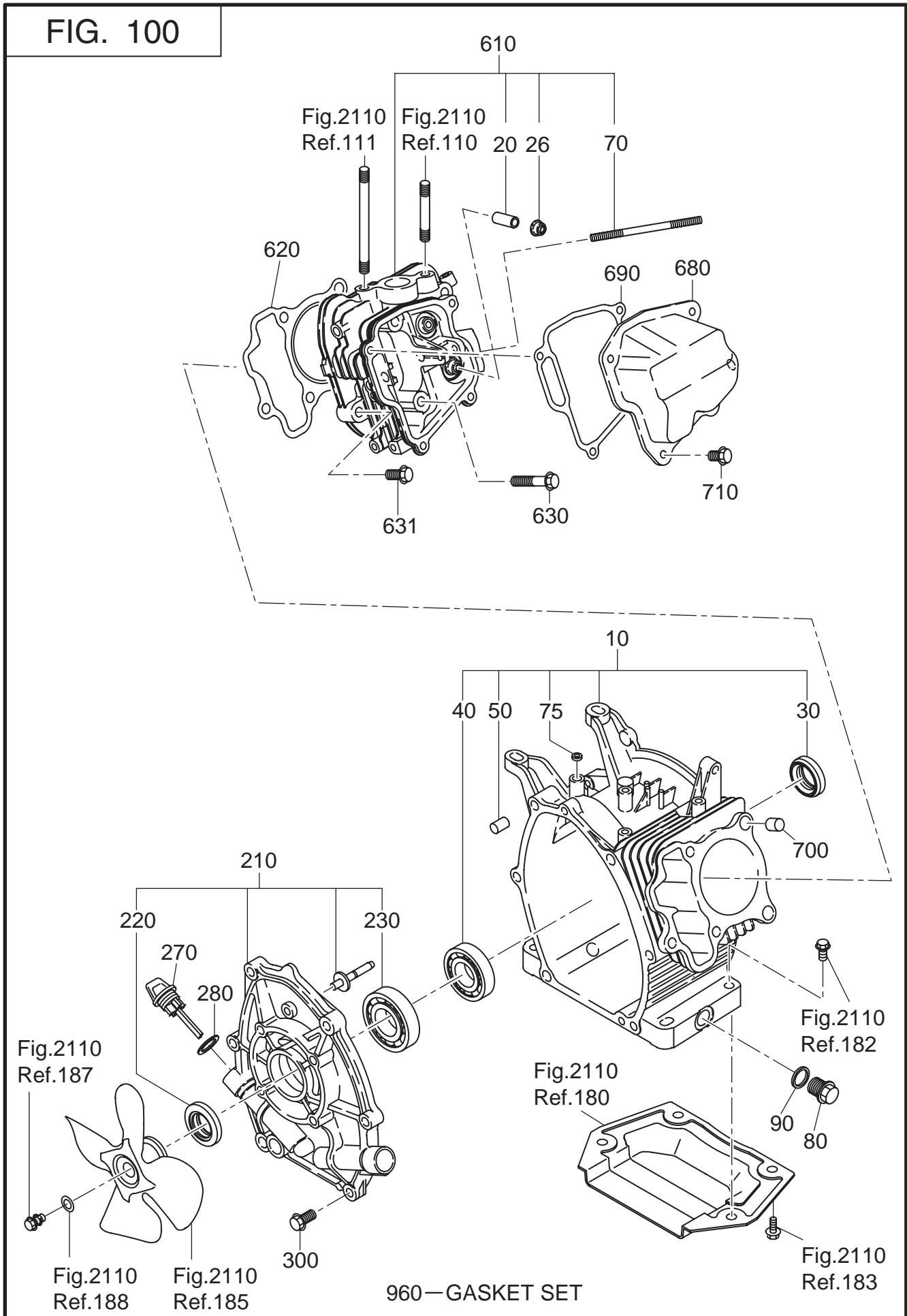

FIG. 100



# 1 CRANK CASE

REF.	PARTS NUMBER	PARTS NAME	QTY	REMARKS	CODE NO. FROM-TO	INTERCHANGEABLE PART NUMBER	UNIT PRICE	FIG.
10	278-10102-41	CRANK CASE CP	1		-			100
20	237-14202-03	VALVE GUIDE	2	O.S.	-			100
26	277-16010-01	STEM SEAL	1		-			100
30	044-02502-00	OIL SEAL	1		-			100
40	060-02800-21	BALL BEARING	1		-			100
50	277-15011-03	PIPE KNOCK	2		-			100
70	010-50603-51	STUD	2	6DX98L	-			100
75	044-00600-20	OIL SEAL	1		-			100
80	040-11400-30	PLUG	2		-			100
90	021-11400-20	GASKET	2		-			100
210	277-11001-31	MAIN BEARING COVER C	1		-			100
220	044-02502-10	OIL SEAL	1		-			100
230	060-02501-40	BALL BEARING	1		-			100
270	277-63601-13	OIL GAUGE	2		-			100
280	021-31600-20	GASKET	2		-			100
300	001-04083-50	FLANGE BOLT	6		-			100
610	278-13005-01	CYLINDER HEAD CP	1		-			100
620	277-15001-23	GASKET (HEAD)	1		-			100
630	011-00802-40	FLANGE BOLT	4	M8X68L	-			100
631	011-00803-10	FLANGE BOLT	1	M8X33L	-			100
680	277-15501-01	ROCKER COVER CP	1		-			100
690	277-16001-13	GASKET (ROCKER COVER)	1		-			100
700	277-15011-03	PIPE KNOCK	2		-			100
710	011-00600-20	FLANGE BOLT	4	M6X12L	-			100
960	277-99001-27	GASKET SET	1		-			100

FIG. 200

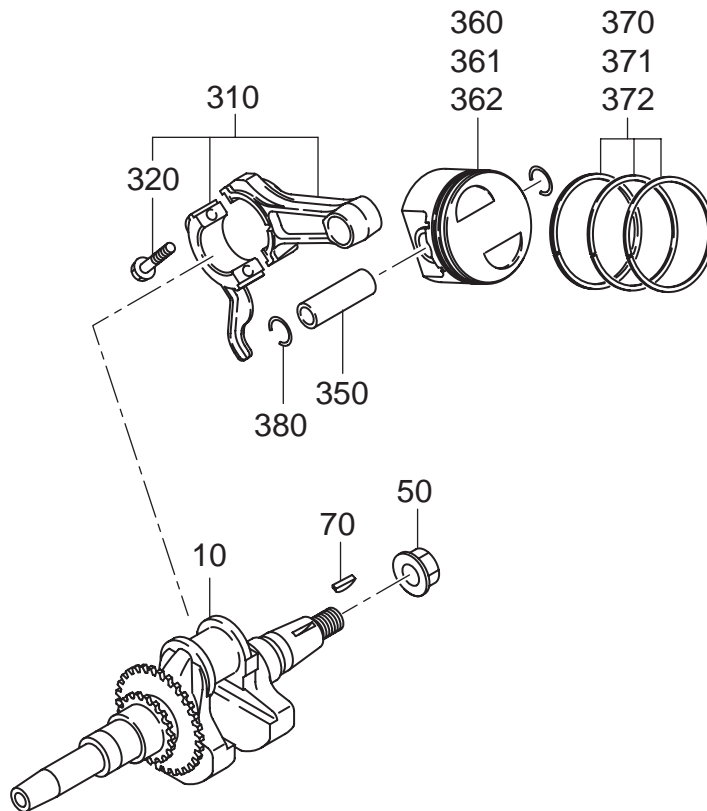



FIG. 300

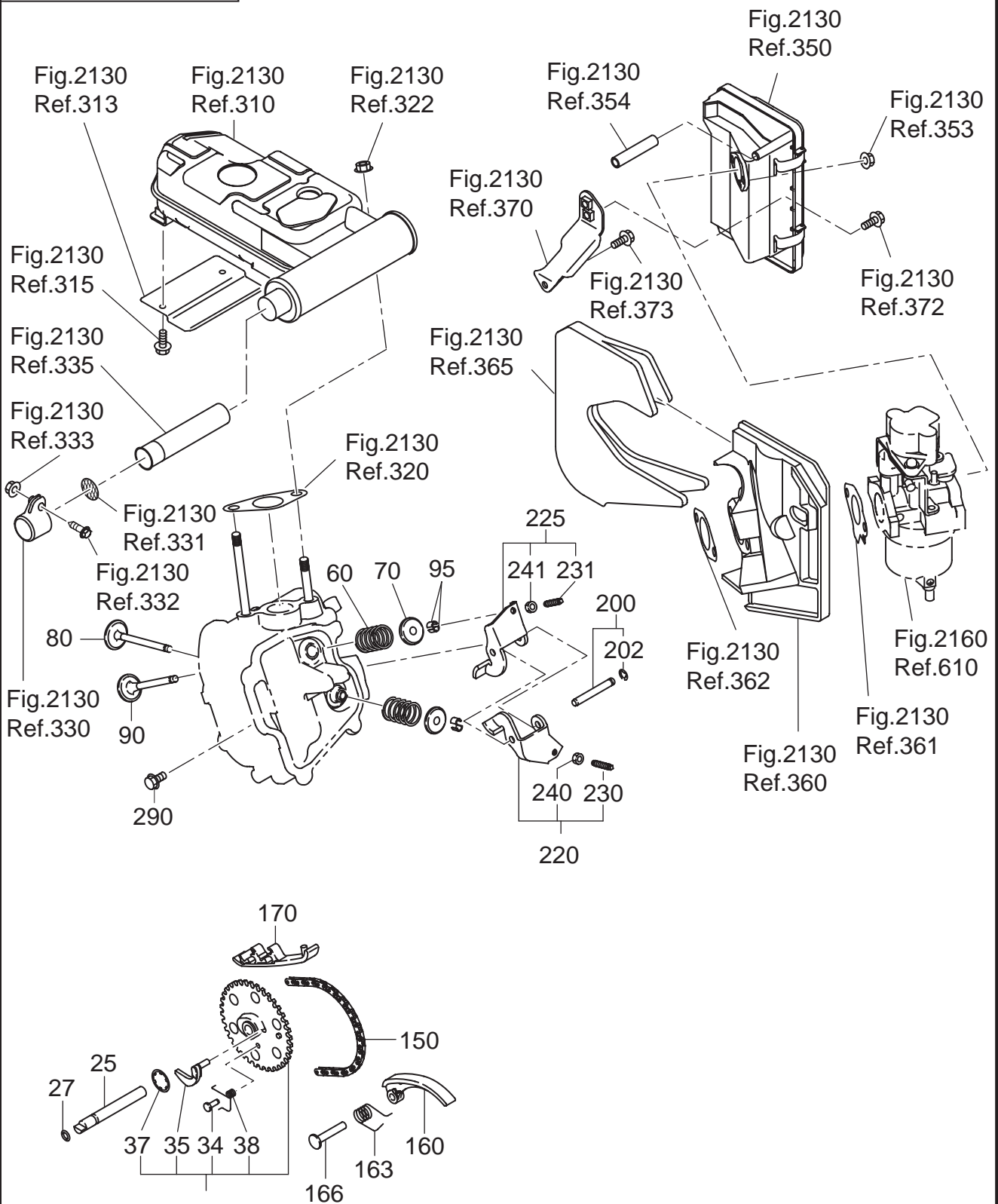





FIG. 400

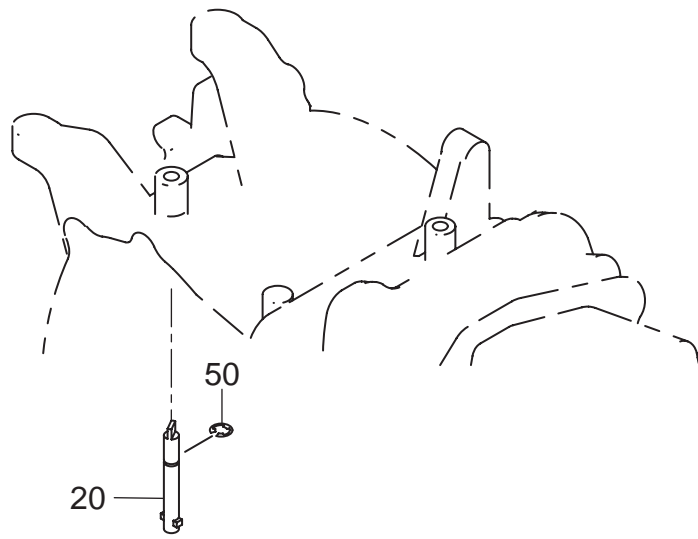



FIG. 500

Fig.2170  
Ref.771

Fig.2170  
Ref.774

Fig.2150  
Ref.510

Fig.2150  
Ref.512

Fig.2150  
Ref.520

Fig.2150  
Ref.522

Fig.2150  
Ref.515

60

Fig.2150  
Ref.515

135

Fig.2150  
Ref.580

Fig.2150  
Ref.530

Fig.2150  
Ref.582

Fig.2150  
Ref.560

Fig.2150  
Ref.562

Fig.700  
Ref.20

Fig.700  
Ref.10

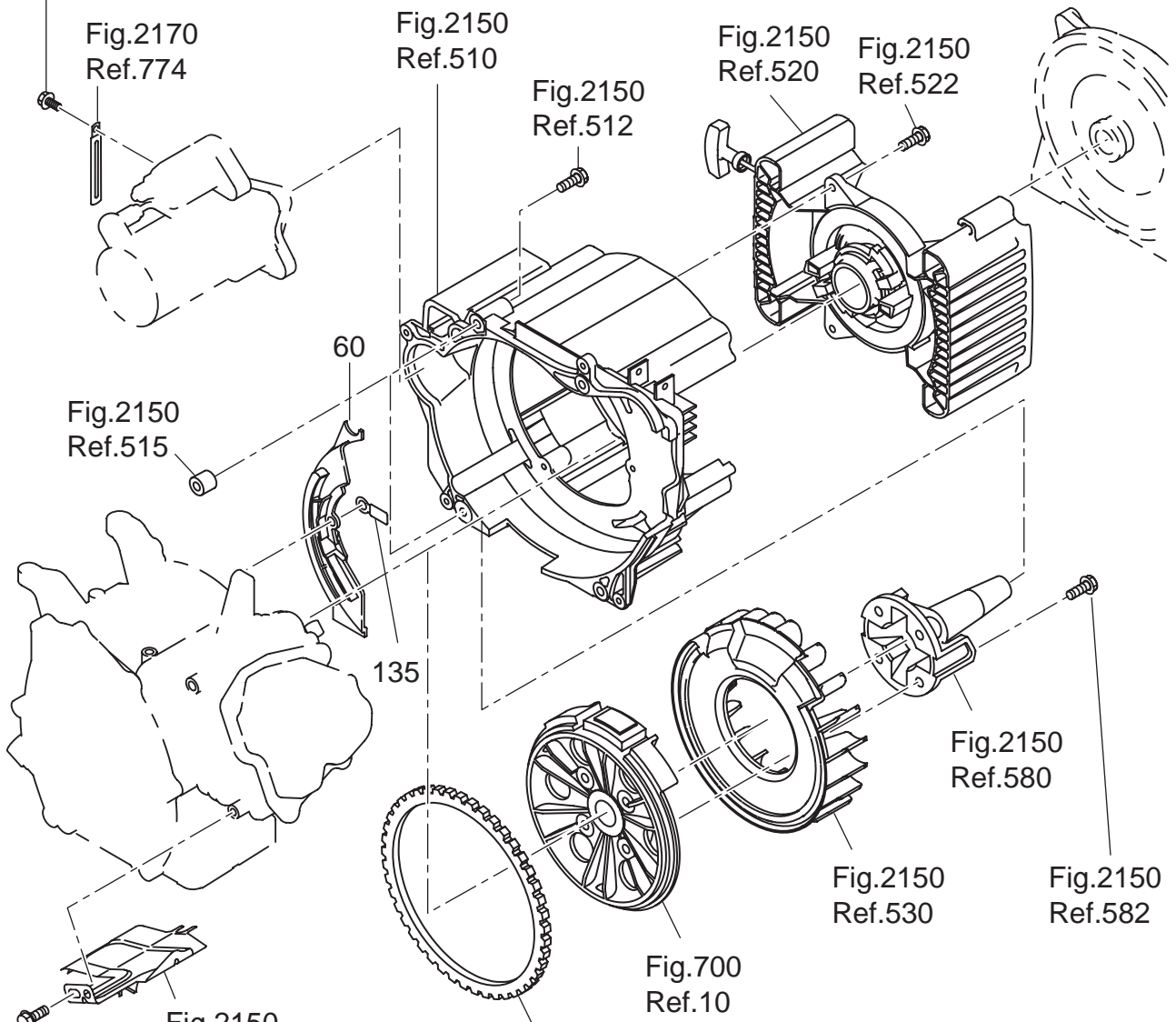



FIG. 700

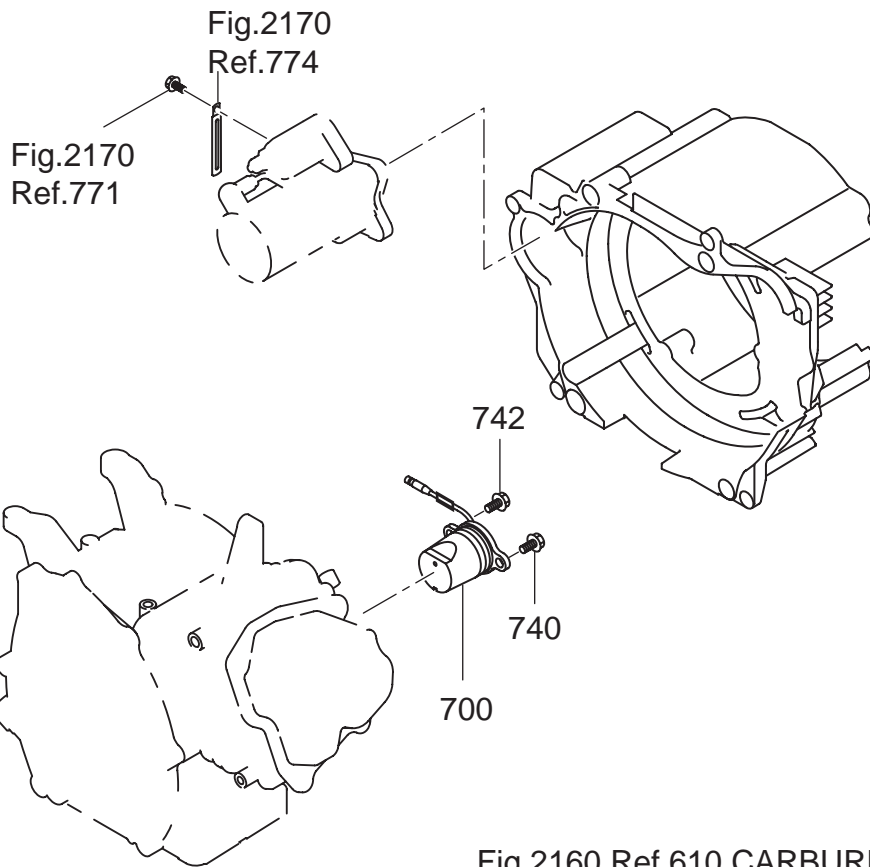
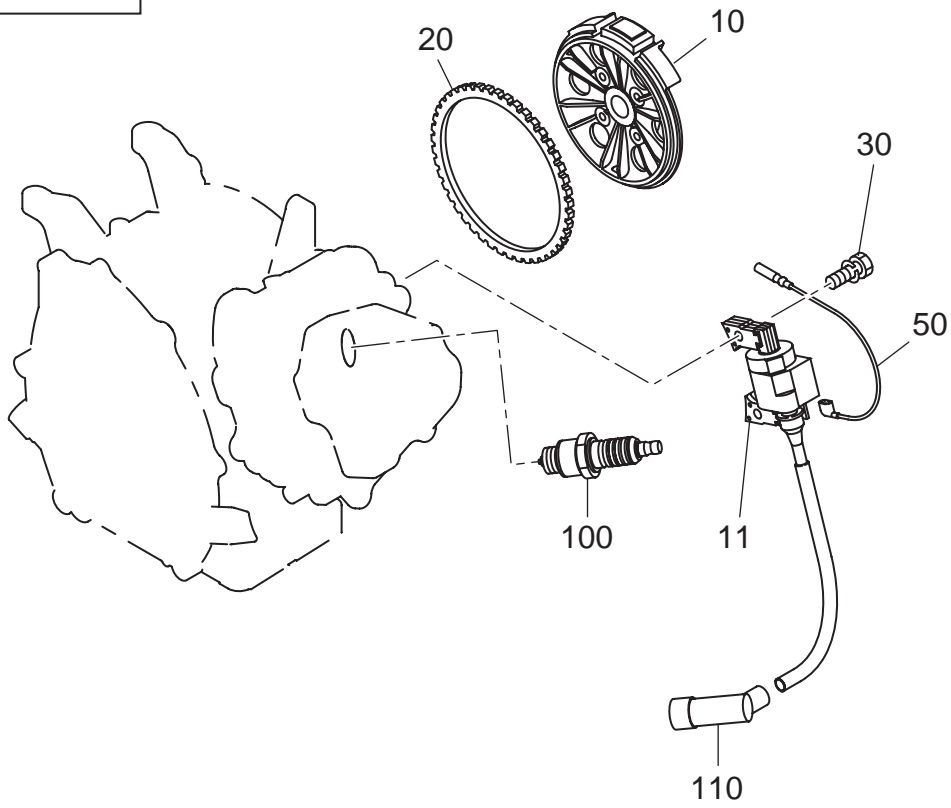

Fig.2160 Ref.610 CARBURETOR AY

FIG. 720

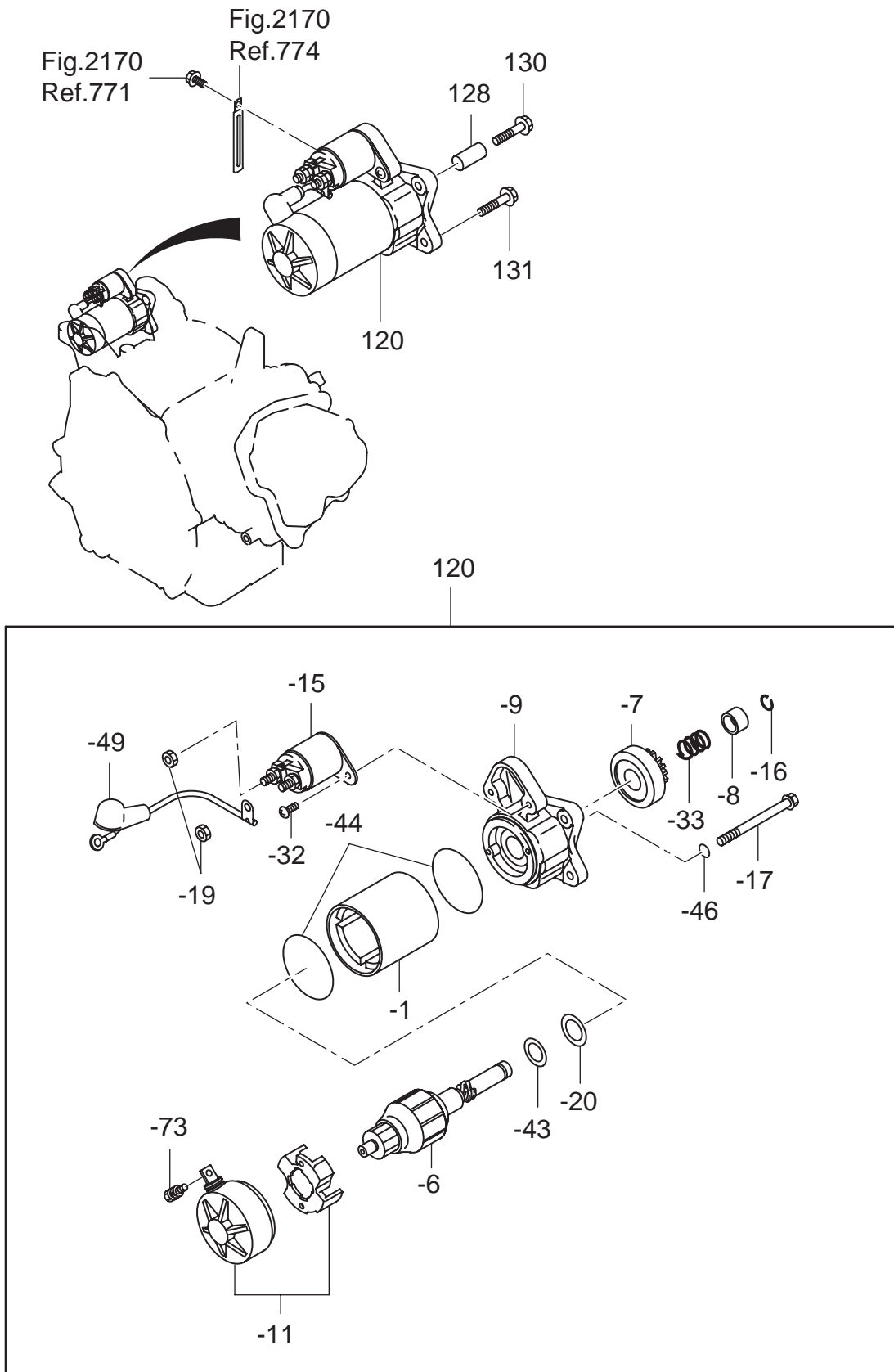
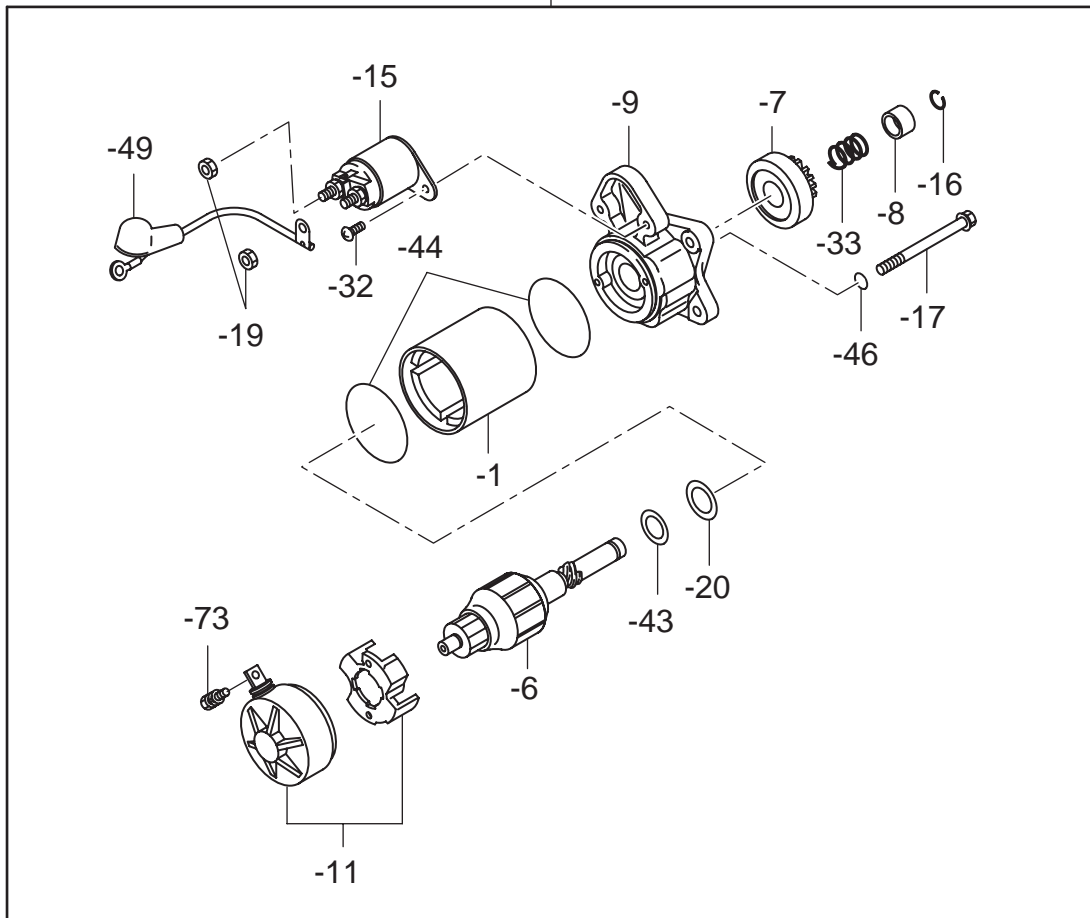
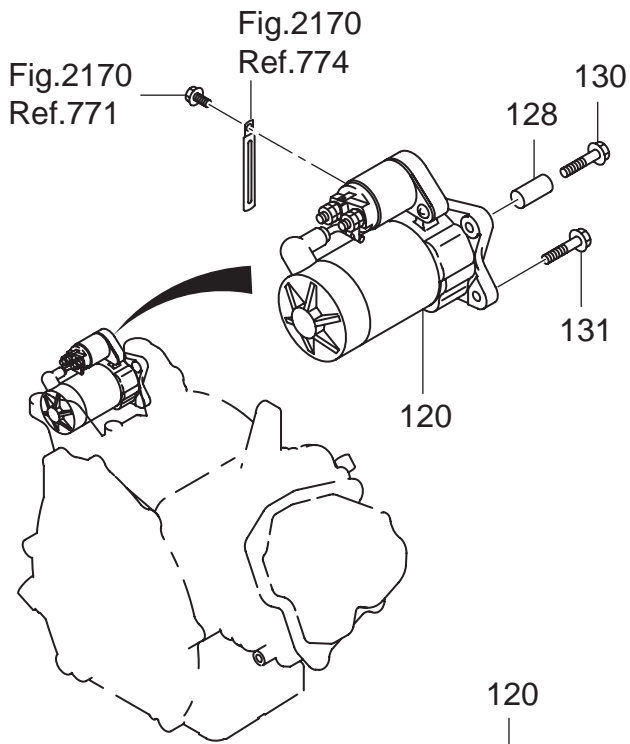

FIG. 720





## 7 ELECTRIC DEVICE

REF.	PARTS NUMBER	PARTS NAME	QTY	REMARKS	CODE NO. FROM-TO	INTERCHANGEABLE PART NUMBER	UNIT PRICE	FIG.
10	277-79231-01	FLYWHEEL CP	1		-			700
11	277-79431-01	IGNITION COIL CP	1		-			700
20	277-71002-03	RING GEAR	1		-			700
30	001-14062-50	BOLT AND WASHER AY	2		-			700
50	279-73105-H1	WIRE 5 CP	1		-			700
100	065-01401-50	SPARK PLUG	1		-			700
110	065-50002-70	SPARK PLUG CAP	1		-			700
700	277-76301-11	OIL SENSOR CP	1		-			700
740	001-14061-60	BOLT AND WASHER AY	1		-			700
742	013-00602-60	BOLT AND WASHER AY	1		-			700
120	277-70502-00	STARTING MOTOR AY	1		-			720
-1	277-70550-08	YOKE AY	1		-			720
-6	277-70551-08	ARMATURE AY	1		-			720
-7	277-70520-08	CLUTCH, SUB-AY	1		-			720
-8	227-70561-08	NUT (PINION STOP)	1		-			720
-9	277-70501-08	GEAR HOUSING AY	1		-			720
-11	277-70502-08	FRAME AY	1		-			720
-15	277-70573-08	CONTACTOR AY	1		-			720
-16	227-70562-08	RING, SNAP	1		-			720
-17	277-70570-08	THROUGH BOLT	2		-			720
-19	254-70576-08	NUT	2		-			720
-20	227-70573-08	WASHER	1		-			720
-32	277-70574-08	SCREW	2		-			720
-33	277-70560-08	SPRING	1		-			720
-43	227-70574-08	COLLER	1		-			720
-44	227-70572-08	O RING	2		-			720
-46	277-70571-08	O RING	2		-			720
-49	277-70572-08	WIRE, SUB-AY	1		-			720
-73	227-70577-08	BOLT	1		-			720
128	980-40081-10	STR PIN -8X10	1		-			720
130	011-00604-80	FLANGE BOLT	1	M6X30L	-			720
131	011-00604-70	FLANGE BOLT	1	M6X20L	-			720

FIG. 2110

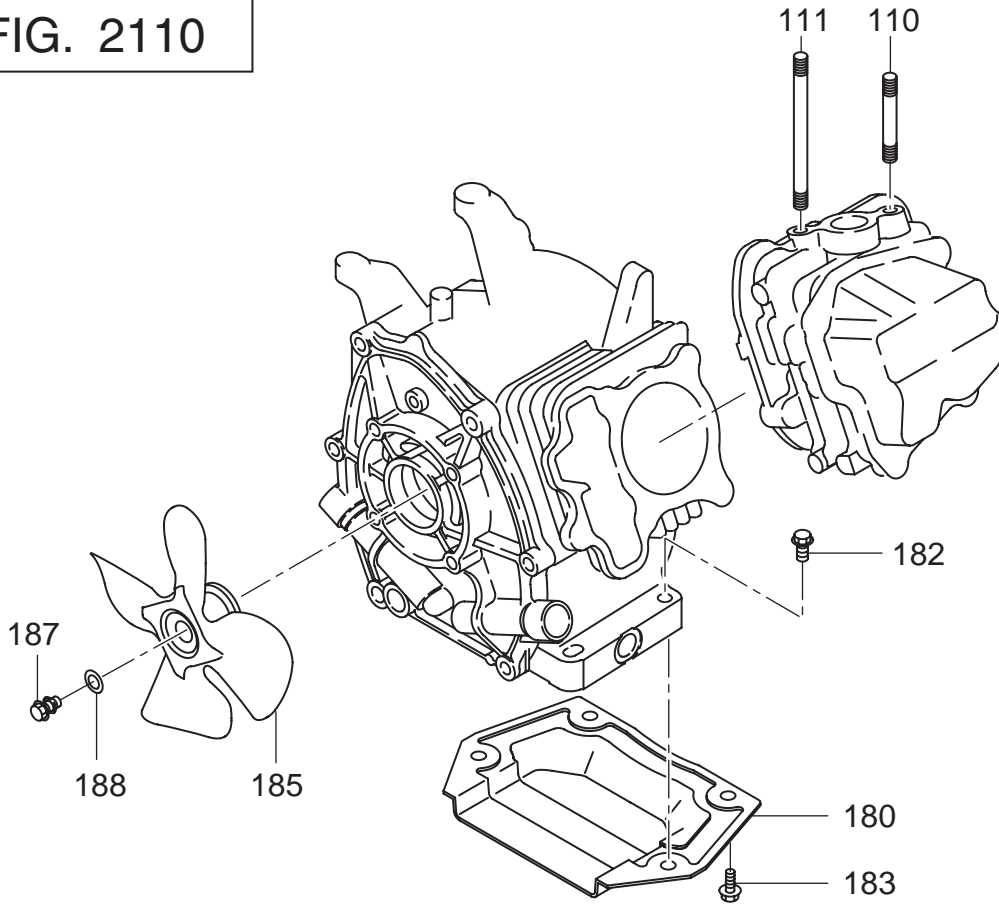

FIG. 2130

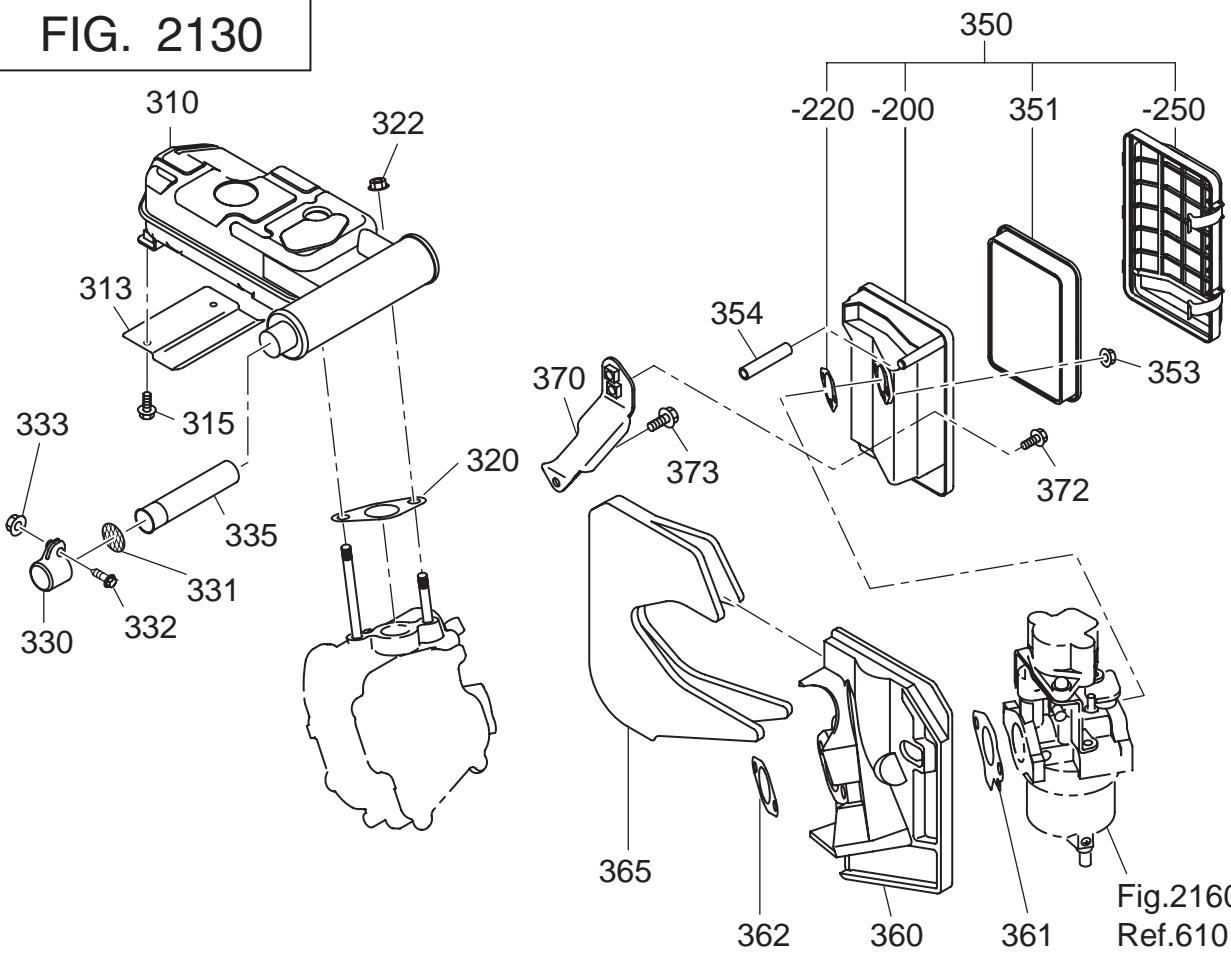

FIG. 2150

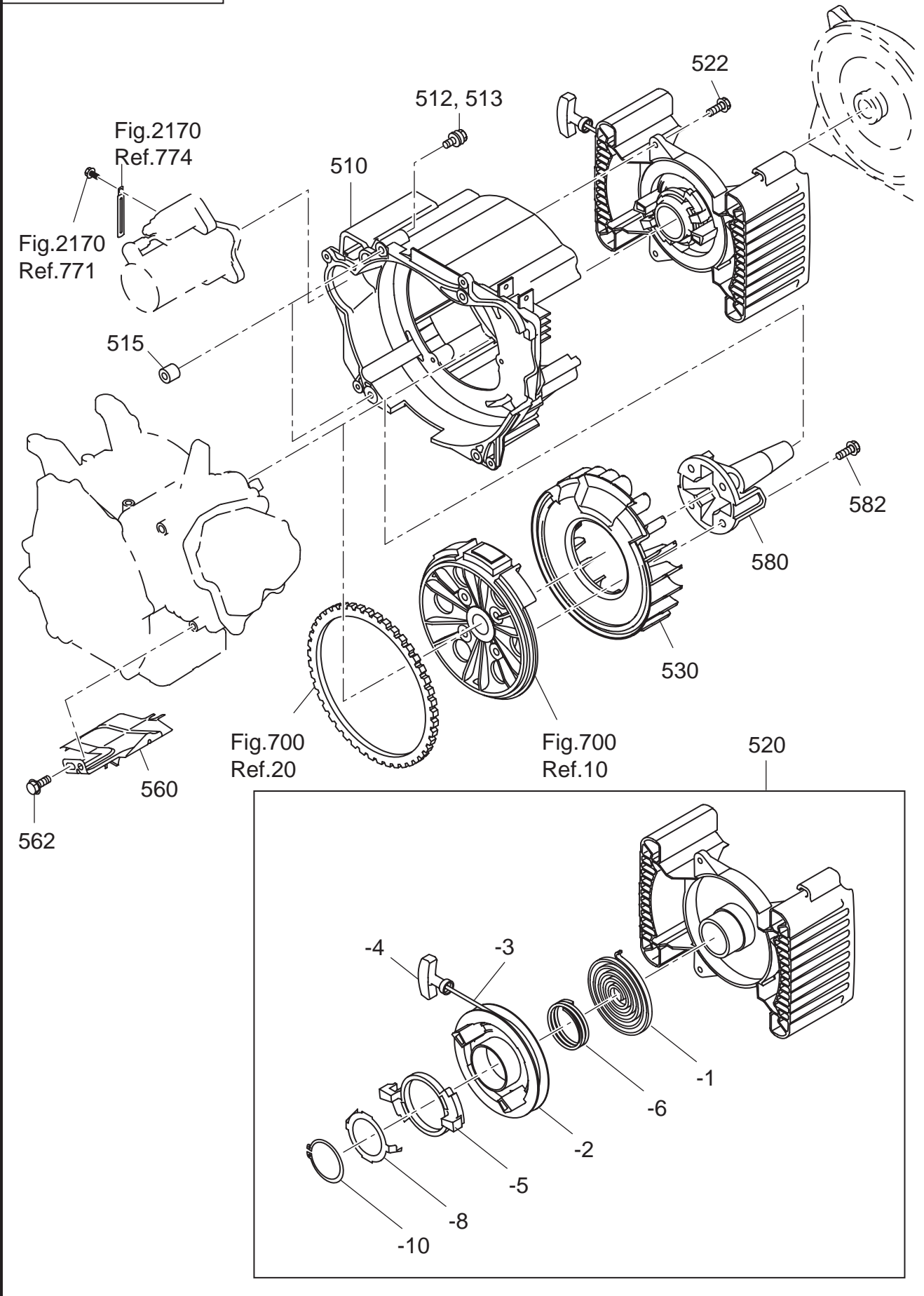

FIG. 2160

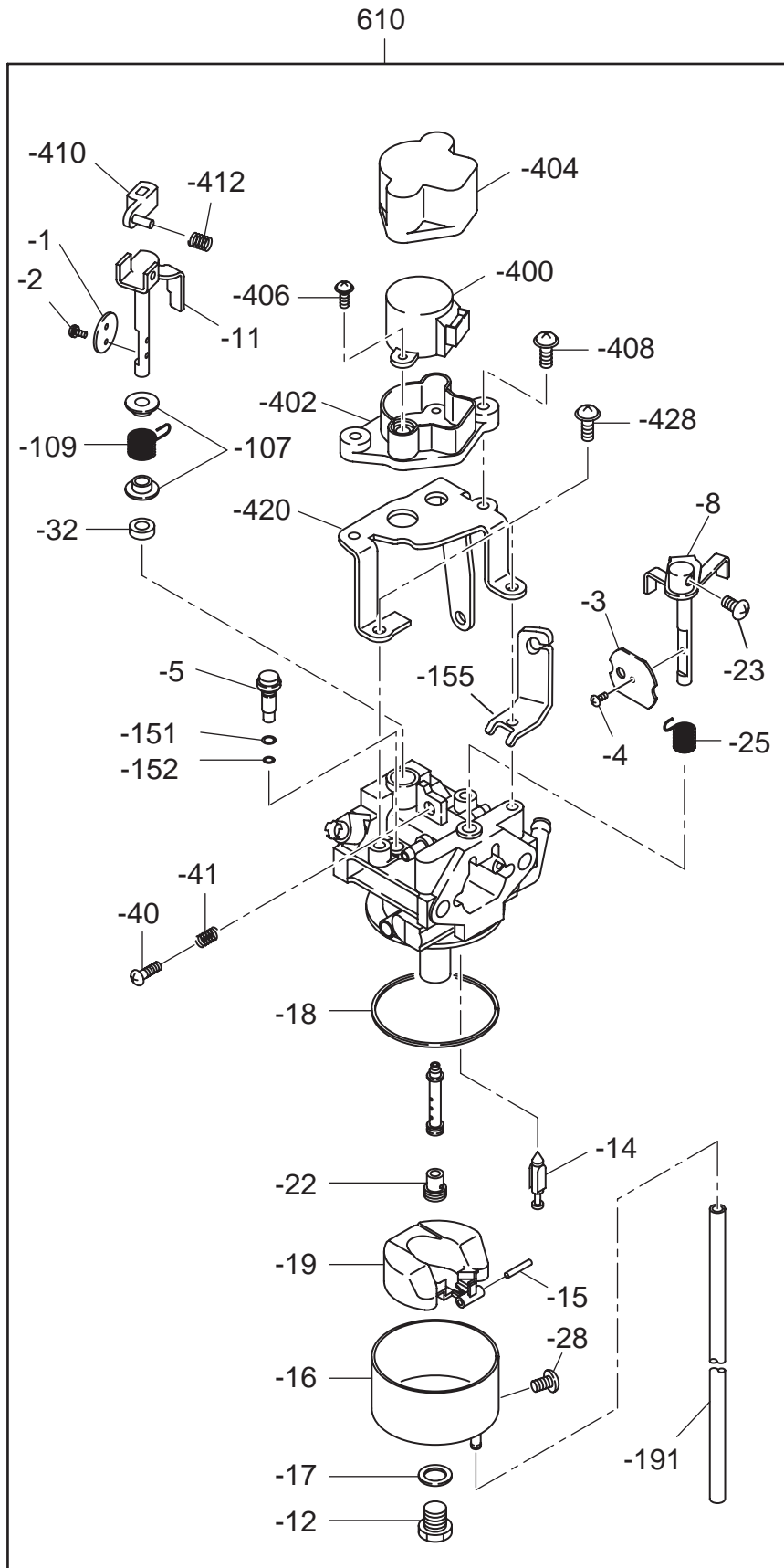
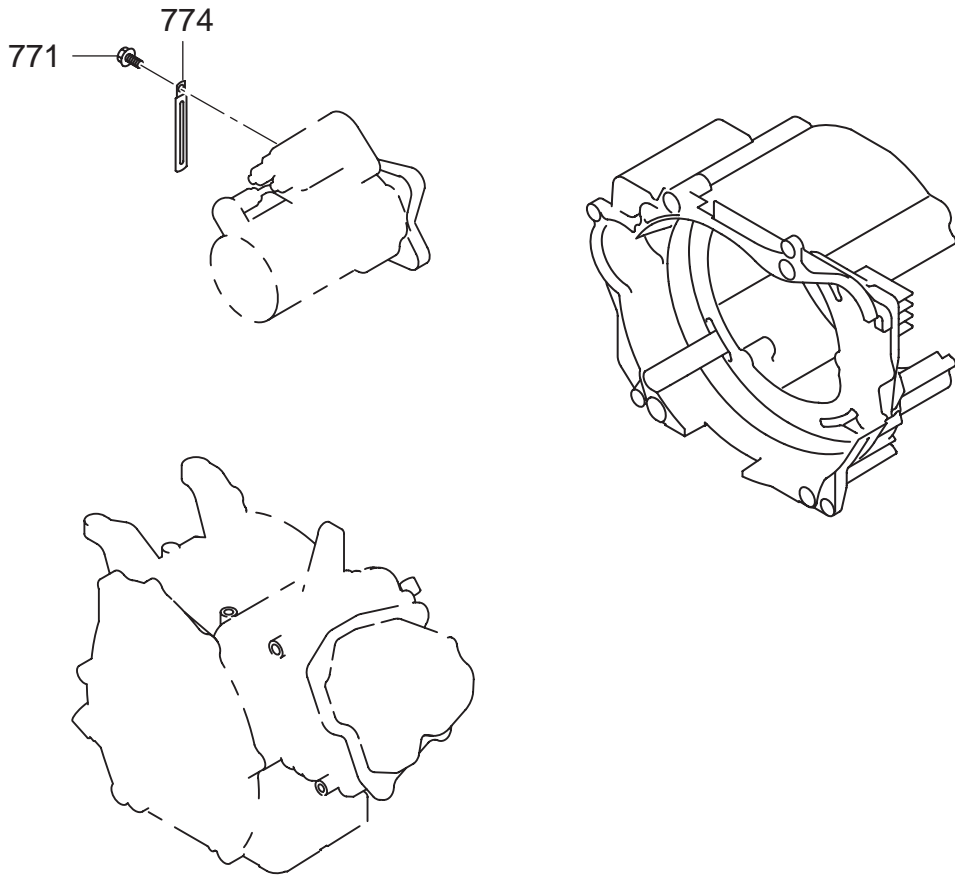

FIG. 2170



## 2 1 ENGINE

REF.	PARTS NUMBER	PARTS NAME	QTY	REMARKS	CODE NO. FROM-TO	INTERCHANGEABLE PART NUMBER	UNIT PRICE	FIG.
110	010-50802-90	STUD	1		-			2110
111	010-50805-10	STUD	1	M8X112L	-			2110
180	33B-35001-01	BOTTOM EXT. PLATE CP	1		-			2110
182	011-00802-70	FLANGE BOLT	2	M8X33L	-			2110
183	011-00801-50	FLANGE BOLT	2	M8X12L	-			2110
185	34G-54101-01	FAN (SILENT) CP	1		-			2110
187	001-14082-50	BOLT AND WASHER AY	1		-			2110
188	020-00800-80	WASHER	1		-			2110
310	278-30412-11	MUFFLER CP (SILENT)	1		-			2130
313	33B-52601-03	BAFFLE	1		-			2130
315	011-00601-60	FLANGE BOLT	2	M6X23L	-			2130
320	277-35201-13	GASKET (MUFFLER)	1		-			2130
322	980-20082-80	FLANGE NUT	2	M8	-			2130
330	277-37210-03	TAIL SCREEN COVER	1		-			2130
331	277-37220-03	SCREEN	1		-			2130
332	004-35051-60	SCREW AND WASHER AY	1		-			2130
333	002-18050-00	NUT	1		-			2130
335	279-37603-01	SPARK ARRESTER CP	1		-			2130
350	277-32622-20	AIR CLEANER AY	1		-			2130
-200	277-32632-08	BASE CP	1		-			2130
-220	277-32604-08	PACKING	1		-			2130
-250	277-32643-18	COVER CP	1		-			2130
351	277-32661-17	ELEMENT SET	1		-			2130
353	002-38060-00	FLANGE NUT	2		-			2130
354	085-10800-00	RUBBER PIPE	1	8DX11D	-			2130
360	277-32910-03	INSULATOR	1		-			2130
361	277-35902-H3	GASKET 1 (INSULATOR)	1		-			2130
362	277-35903-H3	GASKET 2 (INSULATOR)	1		-			2130
365	278-39701-03	SPONGE (INSULATOR)	1		-			2130
370	277-39004-01	BRACKET (A/C) 1 CP	1		-			2130
372	011-00600-50	FLANGE BOLT	1	M6X20L	-			2130
373	011-00600-20	FLANGE BOLT	1	M6X12L	-			2130
510	277-52001-13	BLOWER HOUSING	1		-			2150
512	001-14063-50	BOLT AND WASHER AY	1		-			2150
513	001-14064-50	BOLT AND WASHER AY	3		-			2150
515	980-40081-10	STR PIN -8X10	2	M6	-			2150

## 2 1 ENGINE

REF.	PARTS NUMBER	PARTS NAME	QTY	REMARKS	CODE NO. FROM-TO	INTERCHANGEABLE PART NUMBER	UNIT PRICE	FIG.
520	277-50401-00	RECOIL STARTER AY	1		-			2150
-1	277-50402-08	SPIRAL SPRING	1		-			2150
-2	277-50403-08	REEL	1		-			2150
-3	277-50408-08	STARTER PORE	1		-			2150
-4	277-50409-08	STARTER KNOB	1		-			2150
-5	277-50404-08	RACHET	1		-			2150
-6	277-50405-08	FRICTION SPRING	1		-			2150
-8	277-50407-08	FRICTION PLATE	1		-			2150
-10	277-50406-08	RETAINING RING	1		-			2150
522	011-00601-40	FLANGE BOLT	3	M6X18L	-			2150
530	277-54101-13	COOLING BLOWER	1		-			2150
560	277-52702-03	BAFFLE 2 (HEAD)	1		-			2150
562	011-00600-20	FLANGE BOLT	1	M6X12L	-			2150
580	277-24401-03	DRIVING SHAFT	1		-			2150
582	011-01001-10	FLANGE BOLT	4	M8X27L	-			2150
610	278-62330-00	CARBURETOR AY	1		-			2160
-1	277-62536-08	THROTTLE VALVE	1		-			2160
-2	284-62455-08	SCREW	2		-			2160
-3	284-62525-08	CHOKE VALVE	1		-			2160
-4	284-62455-08	SCREW	1		-			2160
-5	278-62421-08	SLOW JET	1		-			2160
-8	284-62520-08	CHOKE LEVER	1		-			2160
-11	277-62532-08	THROTTLE SHAFT	1		-			2160
-12	284-62355-08	BOLT	1		-			2160
-14	279-62500-08	NEEDLE	1		-			2160
-15	284-62515-08	PIN	1		-			2160
-16	284-62550-08	FLOAT BODY	1		-			2160
-17	251-62350-08	PACKING	1		-			2160
-18	284-62540-08	CHAMBER PACKING	1		-			2160
-19	284-62505-08	FLOAT AY	1		-			2160
-22	278-62402-08	MAIN JET	1		-			2160
-23	284-62456-08	SCREW	1		-			2160
-25	284-62445-08	SPRING (CHOKE)	1		-			2160
-28	251-62466-08	BOLT	1		-			2160
-32	251-62559-08	SEAL	1		-			2160
-40	277-62581-08	ADJUST SCREW	1		-			2160

FIG. 2170

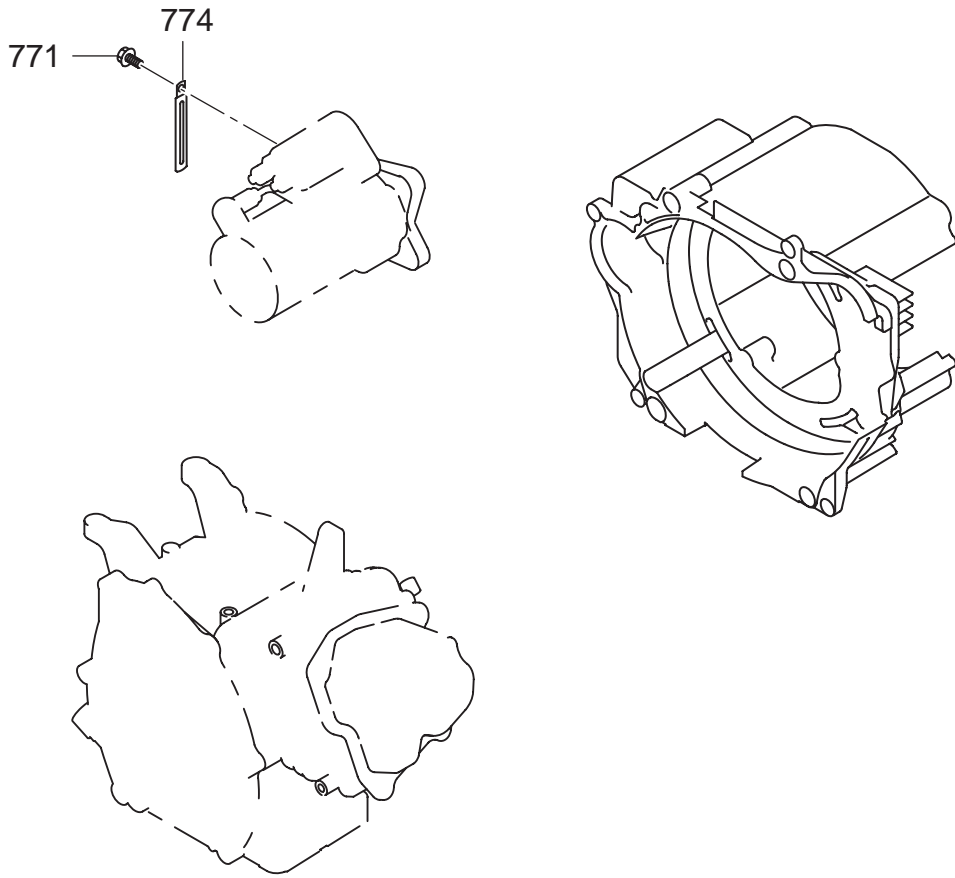



2 1 ENGINE

REF.	PARTS NUMBER	PARTS NAME	QTY	REMARKS	CODE NO. FROM - TO	INTERCHANGEABLE PART NUMBER	UNIT PRICE	FIG.
-41	251-62449-08	SPRING	1		-			2160
-107	284-62561-08	COLLAR	2		-			2160
-109	284-62315-08	SPRING (THROTTLE)	1		-			2160
-151	284-62451-08	O RING	1		-			2160
-152	284-62450-08	O RING	1		-			2160
-155	277-62451-08	BRACKET (WIRE)	1		-			2160
-191	277-62590-08	VINYL PIPE	1		-			2160
-400	284-62580-08	MOTOR	1		-			2160
-402	284-62576-08	BRACKET (MOTOR)	1		-			2160
-404	277-62595-08	COVER (MOTOR)	1		-			2160
-406	284-62458-08	SCREW	2		-			2160
-408	284-62457-08	SCREW	2		-			2160
-410	284-62555-08	JOINT LEVER	1		-			2160
-412	284-62446-08	SPRING	1		-			2160
-420	284-62575-08	BRACKET	1		-			2160
-428	284-62457-08	SCREW	3		-			2160
771	011-00600-10	FLANGE BOLT	1		-			2170
774	056-60002-50	CLAMP	1		-			2170

FIG. 2200

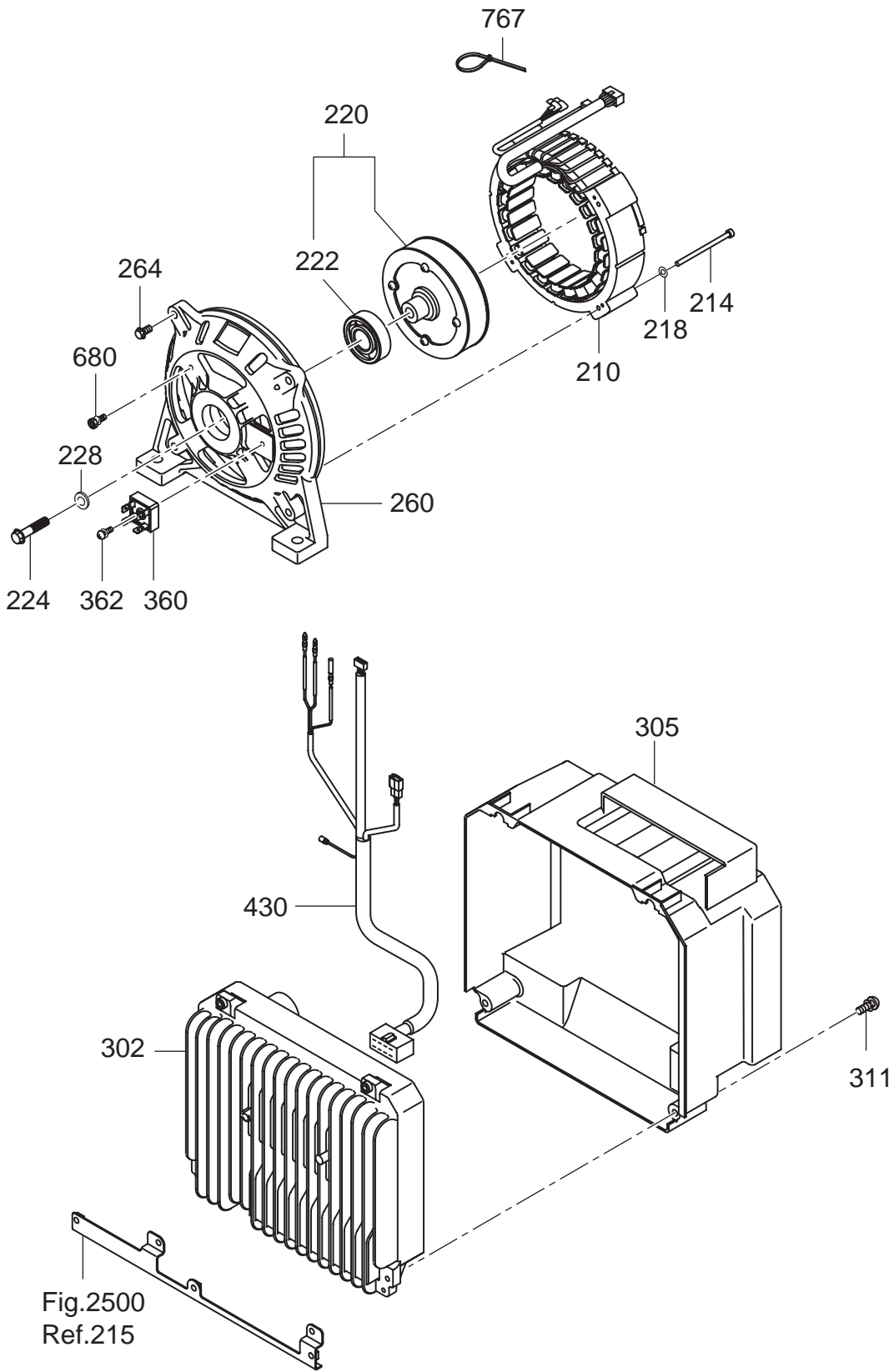

2 2 G E N E R A T O R

REF.	PARTS NUMBER	PARTS NAME	QTY	REMARKS	CODE NO. FROM-TO	INTERCHANGEABLE PART NUMBER	UNIT PRICE	FIG.
210	34C-20051-01	STATOR CP	1		-			2200
214	34C-21051-08	BOLT	4	M5X40L	-			2200
218	003-20050-00	SPRING WASHER	4	M5	-			2200
220	34C-20061-01	ROTOR CP	1		-			2200
222	34B-21001-08	BEARING	1		-			2200
224	010-01002-00	BOLT	1		-			2200
228	020-01001-60	WASHER	1		-			2200
260	34B-23071-01	REAR COVER	1		-			2200
264	001-14062-50	BOLT AND WASHER AY	4		-			2200
302	KU3-10321-21	INV & E/G C/U CP(F10)	1		-			2200
305	34B-55001-03	COVER (INVERTOR)	1		-			2200
311	004-36051-60	SCREW AND WASHER AY	2		-			2200
360	34K-20903-08	RECTIFIER	1		-			2200
362	34K-20904-08	SCREW	1	M4X20L	-			2200
430	34B-48101-01	WIRE HARNESS(E/G) CP	1		-			2200
680	34K-20905-08	SCREW	1	M5X10L	-			2200
767	34K-20907-08	BAND	2		-			2200

FIG. 2300

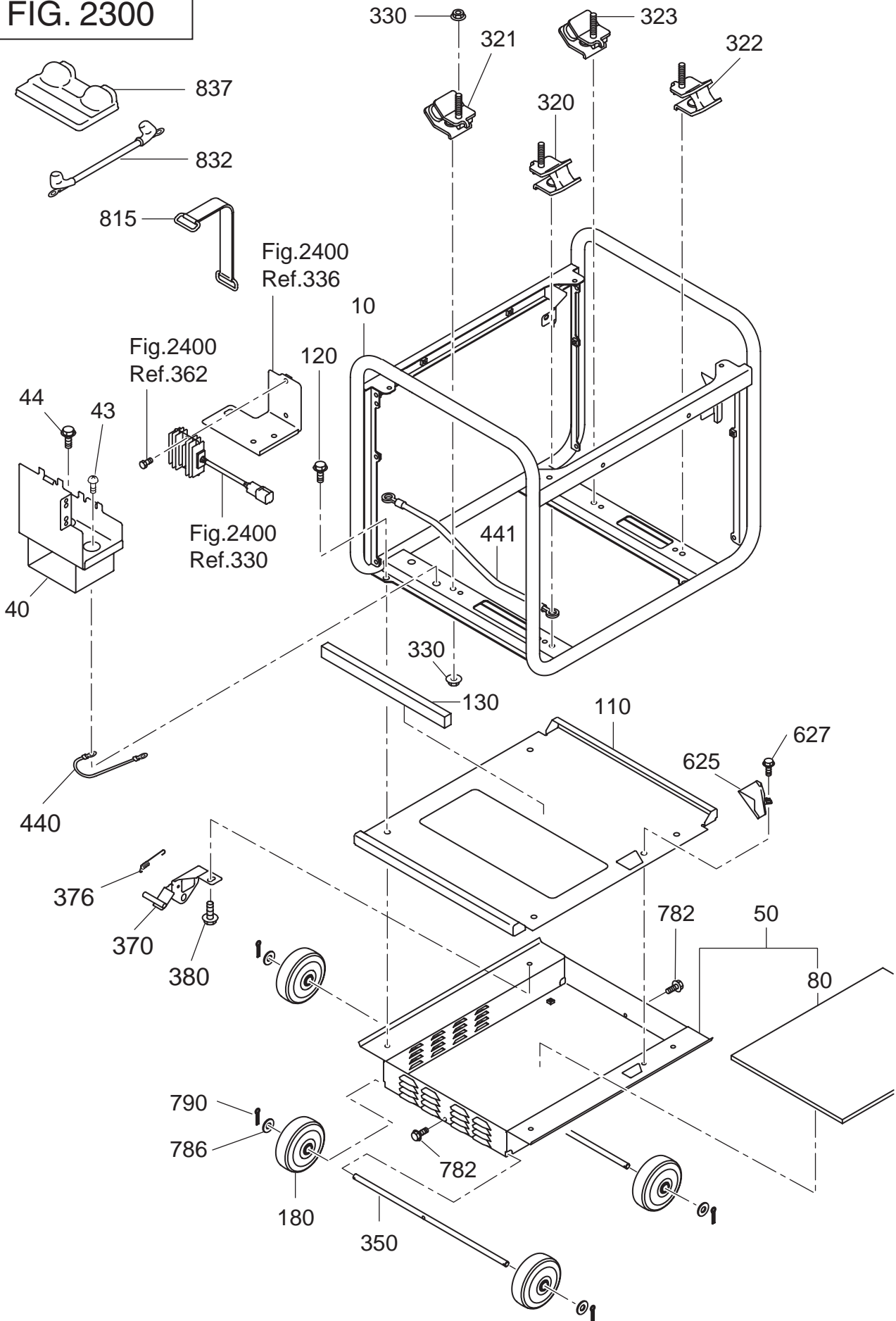

2 3 B A S E , F R A M E

REF.	PARTS NUMBER	PARTS NAME	QTY	REMARKS	CODE NO. FROM - TO	INTERCHANGEABLE PART NUMBER	UNIT PRICE	FIG.
10	34G-30001-01	FRAME CP	1		-			2300
40	33B-35601-01	BATTERY BASE	1		-			2300
43	011-00600-80	FLANGE BOLT	2	M6X12L	-			2300
44	014-00601-21	SCREW	1	M6X8L	-			2300
50	34G-53101-01	BASE PLATE(LOWER) CP	1		-			2300
80	34G-59003-03	SPONGE (BASE)	1		-			2300
110	34G-53002-01	BASE PLATE(UPPER) CP	1		-			2300
120	001-14081-60	BOLT AND WASHER AY	4		-			2300
130	34G-59004-03	SPONGE (BASE)	1		-			2300
180	393-30603-01	WHEEL CP	4		-			2300
320	32B-30211-01	MOUNT CP(R)	1		-			2300
321	32B-30212-01	MOUNT CP(L)	1		-			2300
322	32B-30202-01	MOUNT CP(L)	1		-			2300
323	32B-30201-01	MOUNT CP(R)	1		-			2300
330	002-38080-00	FLANGE NUT	8		-			2300
350	34G-55201-01	SHAFT (WHEEL) CP	2		-			2300
370	34G-56002-10	BRAKE -2 AY	1		-			2300
376	34G-56102-13	SPRING (BRAKE)	1		-			2300
380	001-14081-60	BOLT AND WASHER AY	1		-			2300
440	33B-48091-01	EARTH WIRE CP	1		-			2300
441	34B-48091-01	EARTH WIRE CP	1		-			2300
625	34G-55211-21	DRAIN GUIDE CP	1		-			2300
627	011-00600-20	FLANGE BOLT	1	M6X12L	-			2300
782	011-00600-20	FLANGE BOLT	2	M6X12L	-			2300
786	003-11120-00	WASHER	3		-			2300
790	005-10302-50	COTTER PIN	4		-			2300
815	33B-58001-01	BATTERY BAND	1		-			2300
832	33B-48071-11	BATTERY WIRE CP	1		-			2300
837	33B-35701-03	BATTERY COVER	1		-			2300

FIG. 2400

60Hz 120V USA

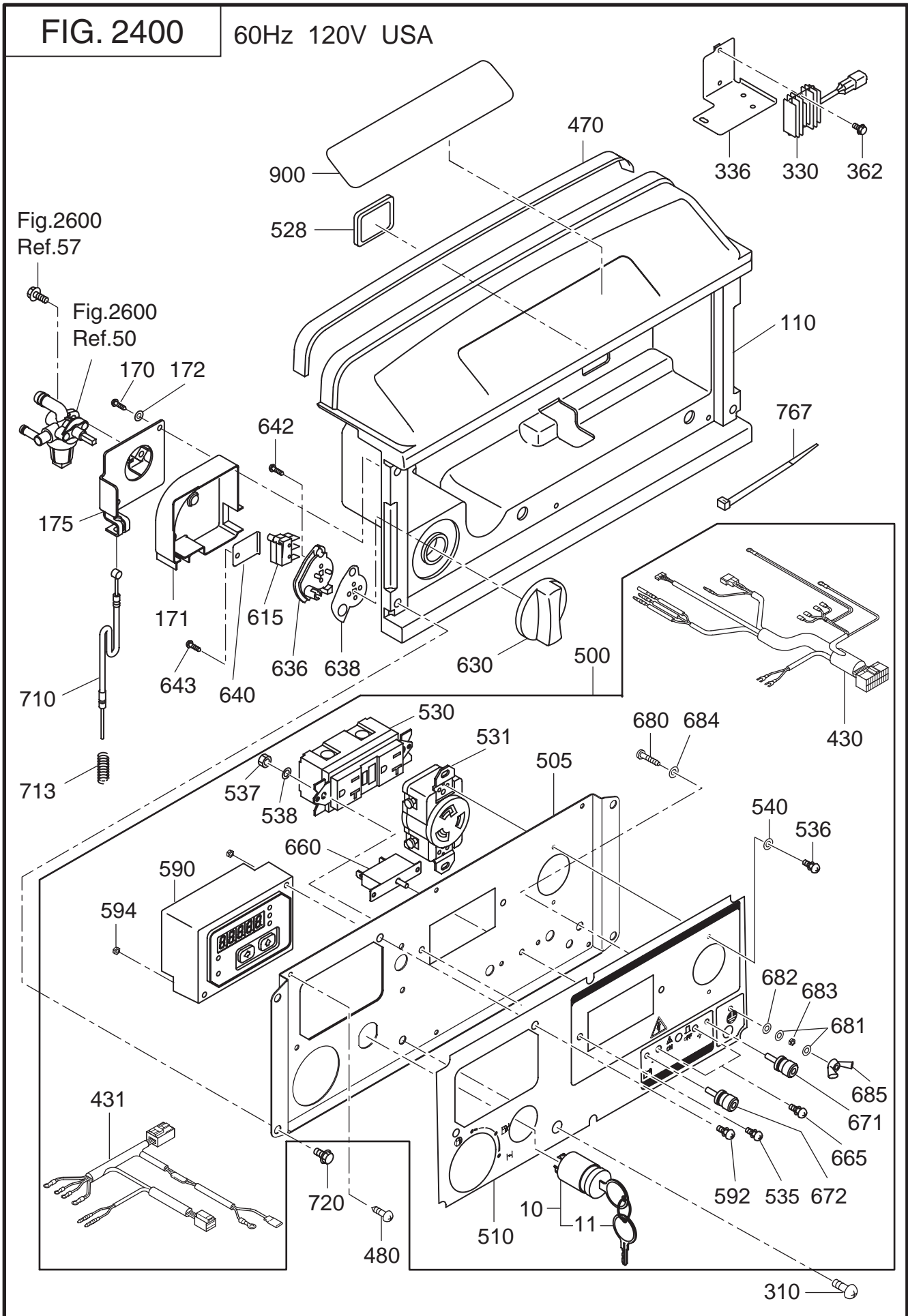

2 4 C O N T R O L

REF.	PARTS NUMBER	PARTS NAME	QTY	REMARKS	CODE NO. FROM-TO	INTERCHANGEABLE PART NUMBER	UNIT PRICE	FIG.
10	066-00003-30	KEY SWITCH	1		-			2400
11	066-00099-80	KEY	2		-			2400
110	33B-50001-01	FRONT COVER(UPPER)CP	1		-			2400
170	015-00400-70	TAPPING SCREW	2		-			2400
171	33B-46001-03	COVER (COCK)	1		-			2400
172	003-10040-00	WASHER	2		-			2400
175	33B-46012-01	BRACKET (COCK)	1		-			2400
310	004-36061-60	SCREW AND WASHER AY	2		-			2400
330	33B-47202-01	REGULATOR CP	1		-			2400
336	33B-35801-02	BRACKET (REG) UN	1		-			2400
362	011-00600-50	FLANGE BOLT	2	M6X20L	-			2400
430	34B-48001-01	WIRE HARNESS CP	1		-			2400
431	33B-48051-01	WIRE HARNESS CP	1		-			2400
470	34B-57311-03	SEAL SPONGE FC2	1		-			2400
480	353-49904-08	TAPPING SCREW	6	M4X10L	-			2400
500	34C-45921-00	CONTROL PANEL AY	1		-			2400
505	33B-45013-01	PANEL PLATE CP	1		-			2400
510	34B-49119-03	SHEET (PANEL VS) 19	1		-			2400
528	227-75001-03	GROMMET	1		-			2400
530	388-85003-01	AC CONCENT (GFCI)	1	125V-20A	-			2400
531	356-45711-08	AC CONCENT (NEMA)	1	125V-30A	-			2400
535	004-35041-00	SCREW AND WASHER AY	2		-			2400
536	356-59937-08	SCREW	2		-			2400
537	002-27040-00	NUT	2		-			2400
538	003-10040-00	WASHER	2		-			2400
540	326-00335-08	SPRING WASHER	2		-			2400
590	KU3-11760-11	MONITOR C/U CP(INV1)	1		-			2400
592	013-10400-80	SCREW AND WASHER AY	2	M4X40L	-			2400
594	002-17040-00	NUT	2		-			2400
615	33K-41811-03	MICRO SWITCH	2		-			2400
630	33K-42010-03	CONTROL DIAL	1		-			2400
636	33K-42020-03	CHOKE REEL	1		-			2400
638	33K-42030-13	PLATE	1		-			2400
640	33B-46015-01	BRACKET (MICRO)	1		-			2400
642	33K-41814-08	TAPPING SCREW	2		-			2400
643	015-00400-70	TAPPING SCREW	1	M4X16L	-			2400

FIG. 2400

60Hz 120V USA

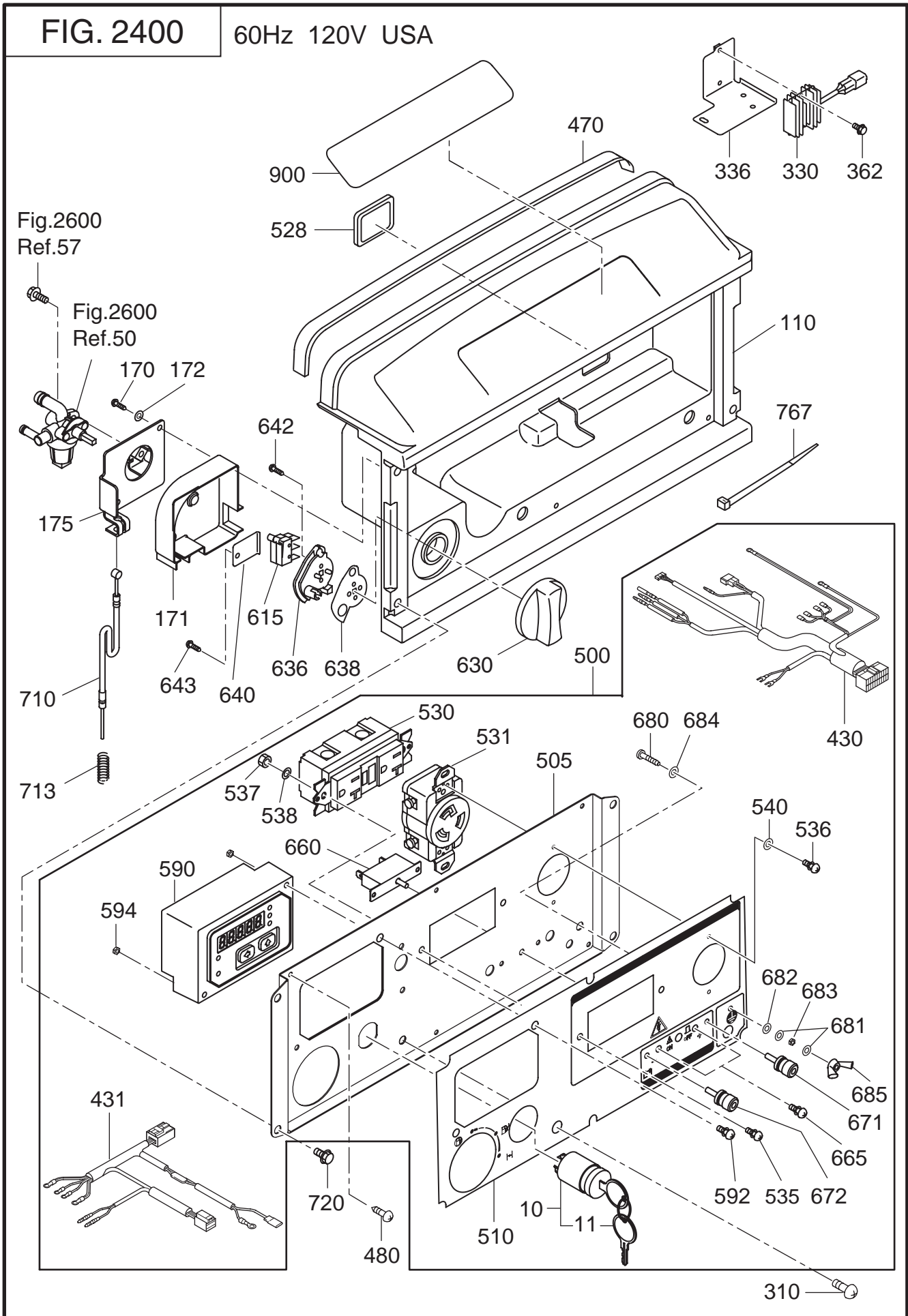



## 2 4 CONTROL

REF.	PARTS NUMBER	PARTS NAME	QTY	REMARKS	CODE NO. FROM-TO	INTERCHANGEABLE PART NUMBER	UNIT PRICE	FIG.
660	352-45620-08	CIRCUIT BREAKER	1	201-10A	-			2400
665	31B-79011-03	SCREW	2		-			2400
671	363-45701-08	TERMINAL BOLT	1	RED	-			2400
672	363-45700-08	TERMINAL BOLT	1	BLACK	-			2400
680	388-88001-03	SCREW AND WASHER AY	1		-			2400
681	332-00050-08	SPRING WASHER	2		-			2400
682	353-49903-08	WASHER	1		-			2400
683	353-49902-08	NUT	1		-			2400
684	003-30050-00	LOCK WASHER	1		-			2400
685	353-49901-08	WING NUT	1		-			2400
710	33B-46021-01	CHOKE WIRE CP	1		-			2400
713	226-45001-03	RETURN SPRING	1		-			2400
720	014-00601-90	SCREW	4	M6X20L	-			2400
767	056-30000-20	WIRE BAND	5		-			2400
900	34H-90003-03	LABEL (TRADE MARK)	1		-			2400

FIG. 2500

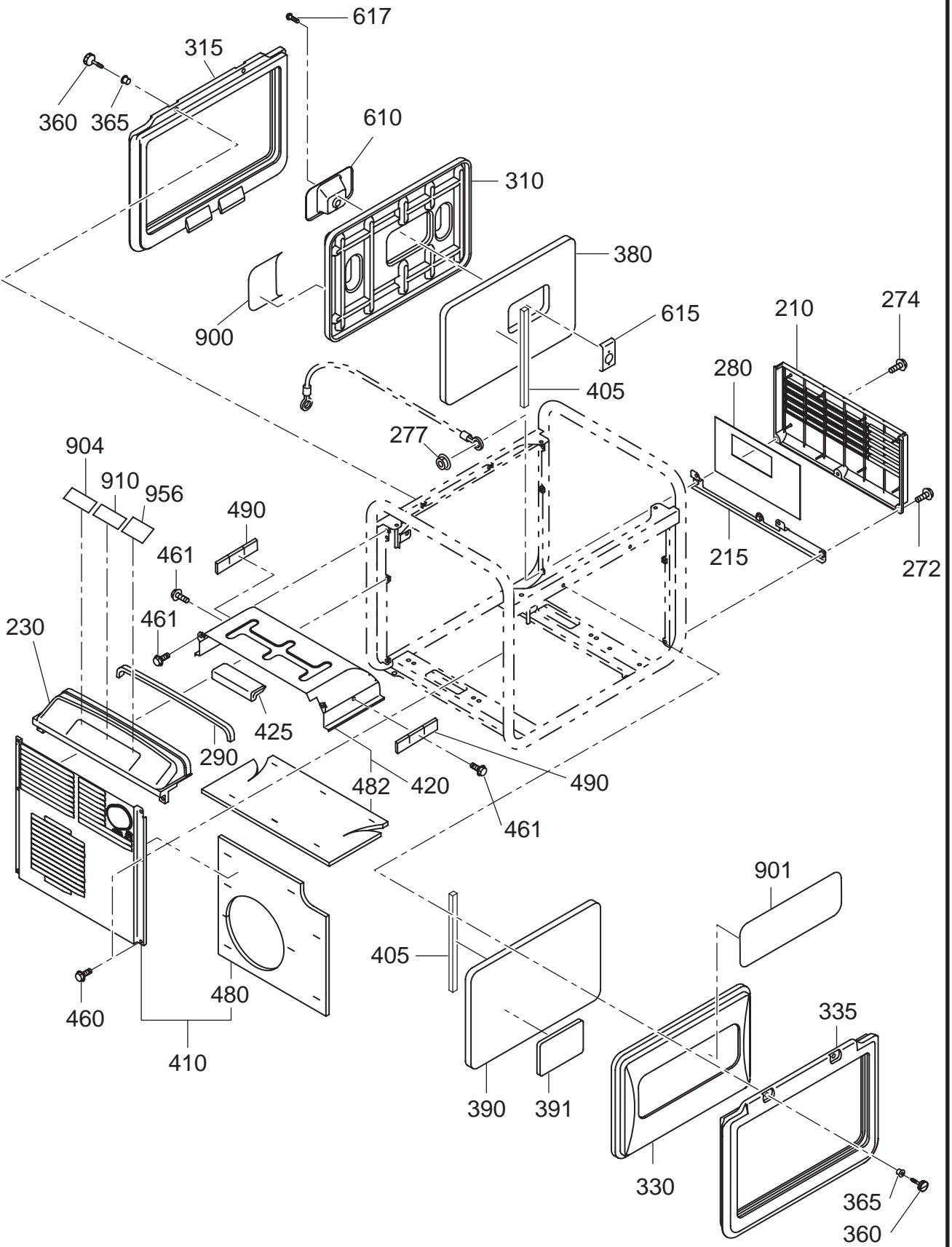
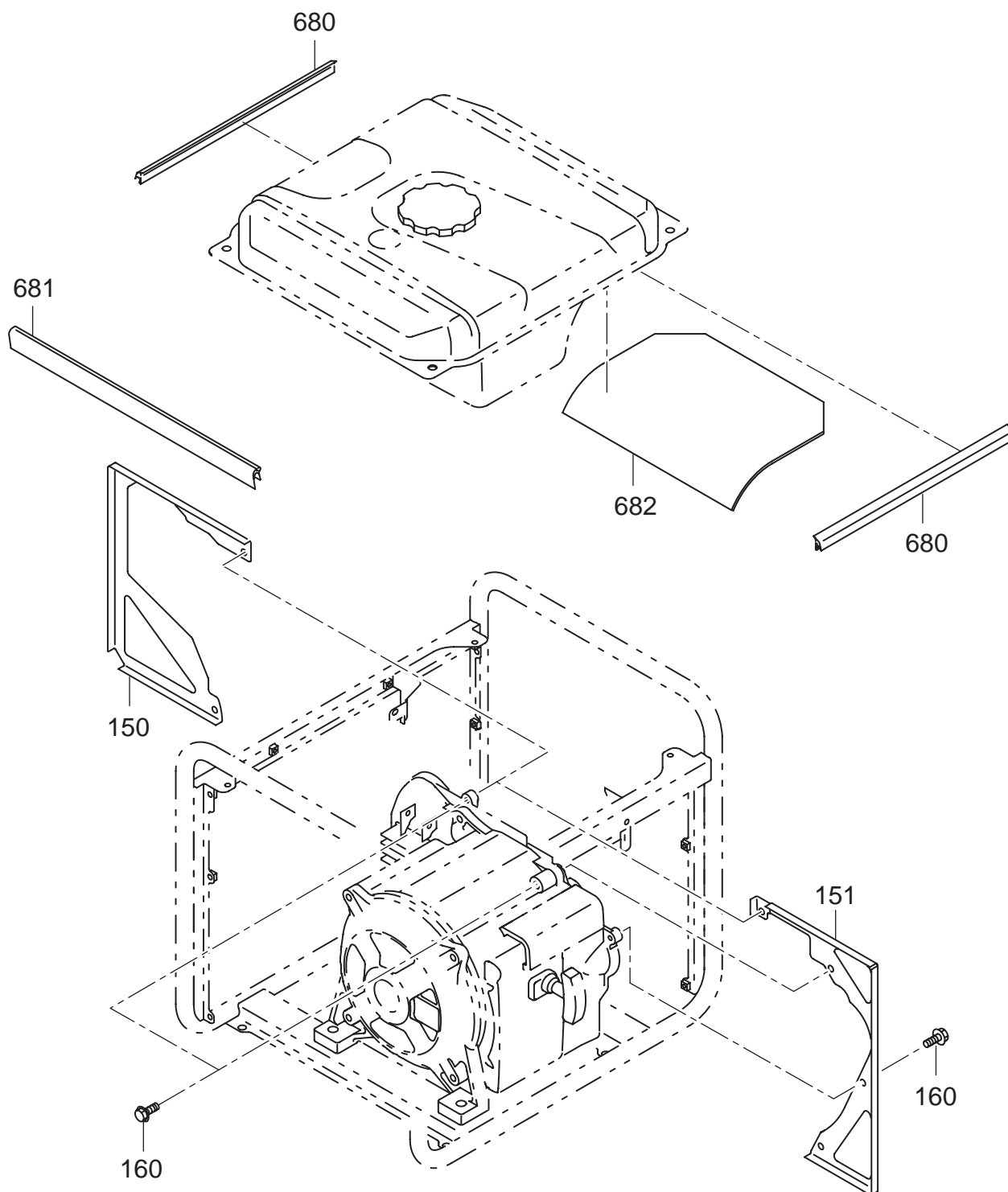

FIG. 2510



2 5 C O V E R

REF.	PARTS NUMBER	PARTS NAME	QTY	REMARKS	CODE NO. FROM-TO	INTERCHANGEABLE PART NUMBER	UNIT PRICE	FIG.
210	33B-50101-01	FRONT COVER(LOWER)CP	1		-			2500
215	33B-35501-01	BRACKET (COVER) CP	1		-			2500
230	33B-50501-01	REAR COVER(UPPER)CP	1		-			2500
272	011-00601-80	FLANGE BOLT	2	M6X18L	-			2500
274	001-11062-50	BOLT AND WASHER AY	1		-			2500
277	002-38060-00	FLANGE NUT	1		-			2500
280	34B-57310-03	SEAL SPONGE FC1	1		-			2500
290	34B-57311-03	SEAL SPONGE FC2	1		-			2500
310	34G-51001-01	SIDE COVER (R) CP	1		-			2500
315	34G-55101-03	SIDE RUBBER SEAL	1		-			2500
330	34G-51101-01	SIDE COVER (L) CP	1		-			2500
335	34G-55101-03	SIDE RUBBER SEAL	1		-			2500
360	34G-55301-01	COVER BOLT CP	4		-			2500
365	34G-55302-01	SPACER CP	4		-			2500
380	34G-59001-13	SPONGE (S COVER-R)	1		-			2500
390	34G-59002-13	SPONGE (S COVER-L)	1		-			2500
391	34G-59008-03	SPONGE (S COVER-L)	1		-			2500
405	34G-57321-03	SEAL SPONGE (SIDE)	2		-			2500
410	33B-56411-01	MUF COVER (REAR)CP	1		-			2500
420	34G-56351-01	MUF COVER (L) CP	1		-			2500
425	33B-57005-03	SEAL RUBBER	1		-			2500
460	011-00601-80	FLANGE BOLT	6	M6X18L	-			2500
461	011-00600-80	FLANGE BOLT	4	M6X12L	-			2500
480	33B-57105-03	GLASS WOOL (M-COVER)	1		-			2500
482	33B-57103-03	GLASS WOOL	1		-			2500
490	34G-57322-03	SEAL SPONGE (MF17.21)	2		-			2500
610	34G-55001-01	COVER(RECOIL KNOB)CP	1		-			2500
615	34G-55002-01	PLATE CP	1		-			2500
617	004-35061-00	SCREW AND WASHER AY	2		-			2500
900	34H-91003-03	LABEL (TRADE MARK-R)	1		-			2500
901	34H-92003-03	LABEL (TRADE MARK-L)	1		-			2500
904	34H-96004-03	LABEL (SPEC)	1		-			2500
910	33K-94002-03	LABEL (CAUTION)	1		-			2500
956	073-20045-00	LABEL (HOT&GAS)	1		-			2500
150	33B-56101-11	SEPARATOR (A/C)	1		-			2510
151	33B-56102-11	SEPARATOR (SEL)	1		-			2510



FIG. 2600

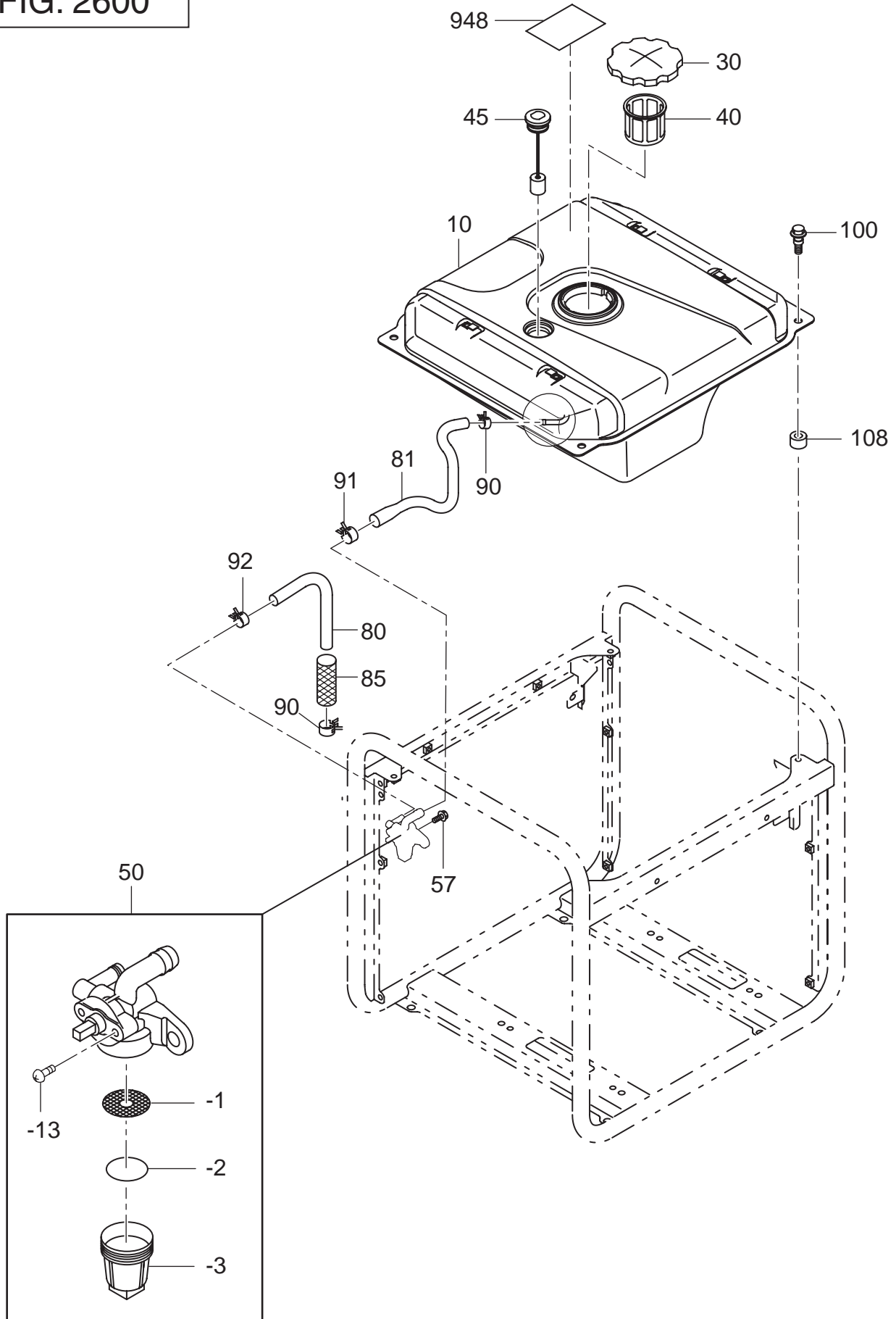

2 6 F U A L T A N K

REF.	PARTS NUMBER	PARTS NAME	QTY	REMARKS	CODE NO. FROM-TO	INTERCHANGEABLE PART NUMBER	UNIT PRICE	FIG.
10	33B-60104-01	FUEL TANK CP	1		-			2600
30	043-05900-11	FUEL TANK CAP AY	1		-			2600
40	064-15400-11	FUEL FILTER	1		-			2600
45	064-80015-00	FUEL GAUGE CP	1		-			2600
50	064-20103-00	FUEL STRAINER AY	1		-			2600
-1	064-20093-20	FILTER	1		-			2600
-2	064-20064-10	GASKET, O-RING	1		-			2600
-3	064-20078-10	CUP	1		-			2600
-13	064-20047-90	SCREW	2		-			2600
57	011-00600-20	FLANGE BOLT	1	M6X12L	-			2600
80	085-10600-00	RUBBER PIPE	1		-			2600
81	33B-66001-03	RUBBER PIPE	1		-			2600
85	251-17302-03	MESH PROTECTOR	1		-			2600
90	056-11100-20	HOSE CLAMP	2	11D	-			2600
91	056-11300-10	HOSE CLAMP	1	13.2D	-			2600
92	056-11000-30	HOSE CLAMP	1	10D	-			2600
100	011-00602-20	FLANGE BOLT	4		-			2600
108	391-39000-13	RUBBER (TANK)	4		-			2600
948	073-20045-10	LABEL (SYMBOL-TANK)	1		-			2600

FIG. 2900

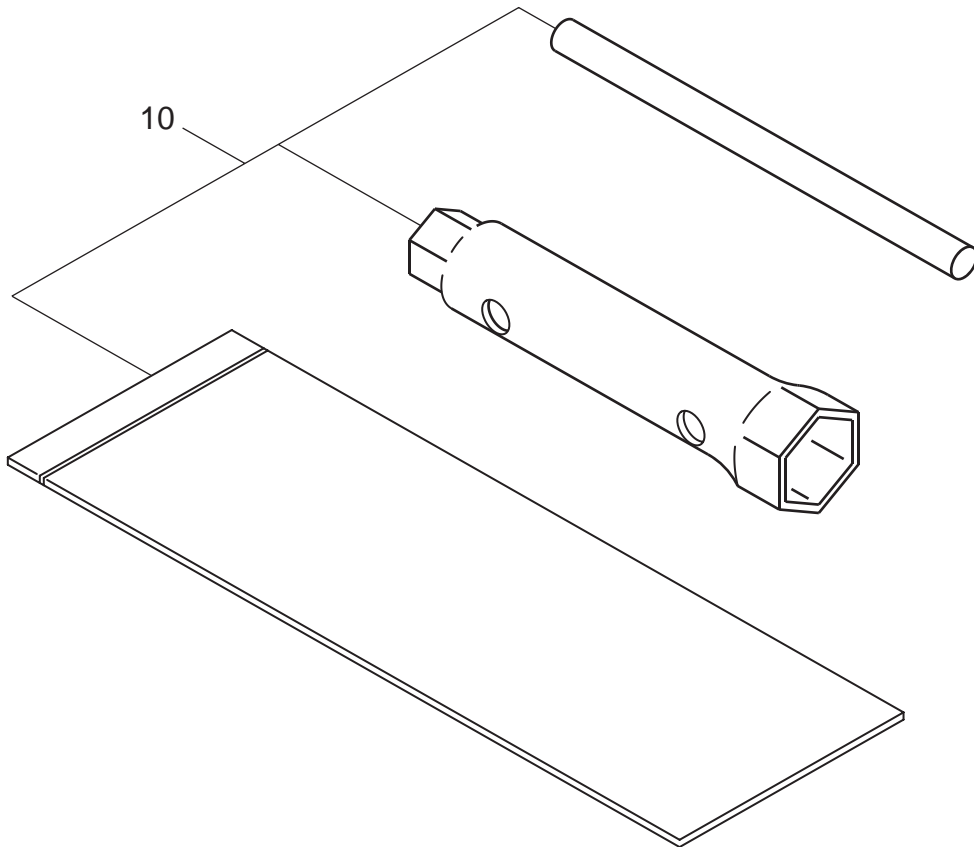



2 9 A C C E S S O R I E S

REF.	PARTS NUMBER	PARTS NAME	QTY	REMARKS	CODE NO. FROM - TO	INTERCHANGEABLE PART NUMBER	UNIT PRICE	FIG.
10	277-90301-H0	ACCESSORY TOOL KIT	1		-			2900